



# Engineering Design Criteria & Standard Drawings

---

**(December 2020)**

## **APPENDIX A – STANDARD DRAWINGS**



## FOREWORD

The Standard Drawings presented are meant to be read in conjunction with the City's Design Criteria document.

The 2020 edition of the Standard Drawings has been prepared in response to the planned growth envisioned by the City's Official Plan and informed by various Master Plan studies for transportation, water, wastewater and stormwater management infrastructure. While the previous stock of Standard Drawings has been simplified and consolidated wherever appropriate, additional standard drawings have been created to address the past experience of the City as well as emerging trends in the industry.

Changes and revisions will be made to the Design Criteria and Standard Drawings from time-to-time. It is the responsibility of the developer, its engineer(s) and others using this information to obtain and make use of the latest versions available at the time of design.

The Standard Drawings are unique to the City of Vaughan and take precedence over any Ontario Provincial Standard Drawings (OPSD) for similar matters, unless approved otherwise by the City.

If no standard drawing is provided by the City, the OPSD are to be consulted and referenced. In the event that OPSD does not contained the required standard, the developer, through its engineer, may prepare a standard for the review and approval of the City prior to the submission of any designs.



Please consider the environment before printing.

## STANDARD DRAWING INDEX

SECTION	PRIOR REF 2004	DESCRIPTION
<b>GENERAL</b>		
G-101		BASE MAP
G-102		LEGEND OF SYMBOLS
G-103		ABBREVIATIONS
G-104		GEODEDIC CONTROL SURVEY MARKER – TYPE A
G-105		GEODEDIC CONTROL SURVEY MARKER – TYPE B
G-106		GEODEDIC CONTROL SURVEY MARKER – ENGRAVING/STAMPING
G-107		GEODEDIC CONTROL CONCRETE SURVEY MARKER
G-108		PROJECT SIGN
<b>ROADS</b>		
R-101	B3/B8	MAJOR COLLECTOR ROAD - 26m R.O.W./MAJOR COLLECTOR ROAD – 26m ROW – 14m PAVEMENT
R-102		MINOR COLLECTOR ROAD - 24m R.O.W. (WITH LAY-BY LANE)
R-103		MINOR COLLECTOR ROAD - 24m R.O.W. (W/O LAY-BY LANE)
R-104	B12	LOCAL ROAD - 17.5m R.O.W. - 8m PAVEMENT
R-105	B13	BUFFER ROAD - 15m R.O.W. - 7m PAVEMENT
R-106	B14	LANEWAY - 8m R.O.W. - 6m PAVEMENT
R-107		CUL-DE-SAC
R-108		ANGLE BEND
R-109		HORIZONTAL CURVE
R-110		INTERSECTION DESIGN GUIDELINES
R-111		STREET SIGNS
R-112		BREAKAWAY BOLLARD DETAIL
R-113		DEAD END BARRICADE
R-114		CONSTRUCTION TRAFFIC BARRICADES
R-115	J-1	TRAFFIC CALMING ADVANCE WARNING SIGNS
R-116	J-2	SPEED HUMP
R-117	J-3	RAISED CROSSWALK
R-118		RAISED INTERSECTION
R-119	J-5	ROUNDAABOUT LAYOUT
R-120	J-6	SINGLE-LANE ROUNDAOUT – NEW DEVELOPMENT AND RE-DEVELOPMENT
R-121	J-7	MINI-ROUNDAABOUT – RE-DEVELOPMENT ONLY
R-122	J-8	TRAFFIC CALMING MEDIANS
R-123	J-9	CURB EXTENSIONS AND ROAD NARROWINGS
R-124		LADDER PAVEMENT MARKING DETAIL AT SIGNALIZED INTERSECTIONS
R-125		CATCHBASIN CURB DETAIL
R-126		CURB AND SUBDRAIN DETAIL
R-127	<i>UNDER DEVELOPMENT</i>	<i>UNIT PAVER CROSSWALK DETAIL</i>
R-128		SIDEWALK AND RAMP
R-129		WALKWAYS
R-130	<i>UNDER DEVELOPMENT</i>	<i>BOLLARD DETAIL</i>
R-131		CONCRETE MULTI-USE PATH DETAIL
R-132		ACTIVE TRANSPORTATION FACILITY (MULTI-USE ASPHALT PATHWAY)
R-133		PEDESTRIAN AND CYCLING FACILITIES
R-134		MAJOR LOCAL ROAD 19M R.O.W. – 8M PAVEMENT
R-135		2-STAGE CURB AND GUTTER

## SEWER SYSTEM

S-101		OUTFALL GRATE MAX. 900mm DIAMETER
S-102		INLET GRATE
S-103		REAR YARD CATCHBASIN GRATE
S-104	K-4	CATCHBASINS
S-105	K-5	PRECAST CATCHBASIN WITHOUT SUMP
S-106		STORM WATER FACILITY POND WARNING SIGN
S-107		SAFETY STATION FOR PONDS AND WATERWAYS
S-108	<i>UNDER DEVELOPMENT</i>	<i>SIDE INLET CATCHBASIN DETAILS</i>
S-109		IFC MAINTENANCE HOLE TAPERED TOP ASSEMBLY
S-110		PATHWAY (TYP.) – ABOVE A NON-CONVENTIONAL SWMF
S-111		ASPHALT PATHWAYS (TYP.) ABOVE A NON-CONVENTIONAL SWMF LOCATED WITHIN PARK
S-112		ARMOUR STONE (TYP.) DETAIL ABOVE A NON-CONVENTIONAL SWMF
S-113		BIKE RACK DETAIL (TYP.) ABOVE A NON-CONVENTIONAL SWMF
S-114		IDENTITY SIGNAGE (TYP.) ABOVE A NON-CONVENTIONAL SWMF
S-115		GATE (TYP.) ABOVE A NON-CONVENTIONAL SWMF
S-116		BOLLARD (TYP.) ABOVE A NON-CONVENTIONAL SWMF
S-117		TREE PLANTING (TYP.) ABOVE A NON-CONVENTIONAL SWMF
S-118		SHRUB PLANTING (TYP.) ABOVE A NON-CONVENTIONAL SWMF
S-119		EXAMPLE STORM CONNECTION DOWNSTREAM FROM A NON-CONVENTIONAL SWMF
S-120		CHAIN LINK SECURITY FENCE (TYP.) ABOVE A NON-CONVENTIONAL SWMF
S-121		PEDESTRIAN BICYCLE HAND RAIL (TYP.) DETAIL ABOVE A NON-CONVENTIONAL SWMF
S-122		ASPHALT PAVING HEAVY DUTY (TYP.) ABOVE A NON-CONVENTIONAL SWMF LOCATED WITHIN ROW
S-123		ASPHALT PAVING LIGHT DUTY (TYP.) ABOVE A NON-CONVENTIONAL SWMF LOCATED WITHIN ROW
S-124		DECORATIVE POLE (TYP.) ABOVE A NON-CONVENTIONAL SWMF
S-125		MAINTENANCE HOLE BUMP OUT FROM PEDESTRIAN PATH FOR NON-CONVENTIONAL SWMF
S-126		CONCEPTUAL STORM SEWER CONNECTION TO NON-CONVENTIONAL SWMF
S-127		CONCEPTUAL NON-CONVENTIONAL SWMF WITHIN ROW LAYOUT

## WATER

W-101		SINGLE VALVE IN CHAMBER
W-102		MULTIPLE VALVE CHAMBER
W-103		AIR RELEASE VALVE CHAMBER
W-104		HYDRANT INSTALLATION
W-105		RESTRAINING OF PVC WATERMAIN AT VALVES AND FITTINGS
W-106		METER, BACKFLOW PREVENTER IN CHAMBER
W-107		METER CHAMBER FOR COPPER SERVICES
W-108		INTENTIONALLY LEFT BLANK
W-109		INDUSTRIAL/COMMERCIAL METER WITH BACKFLOW PREVENTER AND VALVE INSTALLATION (METER ROOM)
W-110		WATER VALVE OPEN/CLOSE DIRECTIONS
W-111		BACKFLOW PREVENTER & CHAMBER FOR 100mm THROUGH 300mm DOUBLE CHECK VALVE ASSEMBLY
W-112	<i>UNDER DEVELOPMENT</i>	<i>TEMPORARY SUPPLY AND DISINFECTION CONNECTION</i>
W-113		WATERMAIN BYPASS SETUP
W-114		FIRE HYDRANT CONNECTION WITH METER AND BACK FLOW PREVENTER
W-115	<i>UNDER DEVELOPMENT</i>	<i>GROUNDWATER FLOW MEASURING DEVICE PIPING LAYOUT</i>
W-116	<i>UNDER DEVELOPMENT</i>	<i>GROUNDWATER SAMPLING ACCESS POINT WITH MAINTENANCE ACCESS HOLE</i>
W-117	<i>UNDER DEVELOPMENT</i>	<i>GROUNDWATER SAMPLING ACCESS POINT</i>
W-118		AUTOMATED IRRIGATION SYSTEM FOR YORK REGION LANDSCAPE MEDIANS

## CONNECTIONS

C-101		RESIDENTIAL SERVICE CONNECTIONS
C-102		BLOCK SERVICE CONNECTIONS
C-103		BLOCK WATER CONNECTION
C-104		STORM CONNECTION WITH ORIFICE CONTROL

## STREET LIGHTING

SL-100a	STANDARD TRENCH FOR DIRECT BURIED CABLES
SL-100b	STANDARD STREETLIGHTING TRENCH
SL-101	INSTALLATION OF STREETLIGHT CABLE AT ROAD CROSSINGS
SL-102	STREETLIGHT WIRING CONNECTIONS
SL-103	INSTALLATION OF BOLLARD WALKWAY LIGHT SERVICE AT STREETLIGHT POLE
SL-104	STREETLIGHT PEDESTAL BASE DETAIL
SL-105	STREETLIGHT PEDESTAL DETAIL
SL-106	POLE HAND HOLE BREAKER SL1-15
SL-107	POLE HAND HOLE BREAKER SL2-15
SL-108	POLE HAND HOLE BREAKER SL1-50
SL-109	POLE HAND HOLE BREAKER SL2-50
SL-110	VICTORIAN SCROLL ARM 1.5M (5')
SL-111	VICTORIAN SCROLL ARM 1.8M (6')
SL-112	ALUMINUM ELLIPTICAL BRACKET 30' (2.5')
SL-113	ALUMINUM ELLIPTICAL BRACKET 1.83M (6')
SL-114	ALUMINUM ELLIPTICAL BRACKET 2.44M (8')
SL-115	ALUMINUM ELLIPTICAL BRACKET 3M (10')
SL-116	ALUMINIUM ELLIPTICAL BRACKET 3.65M (12')
SL-117	TAPERED ROUND CONCRETE POLE 7.6M (25')
SL-118	TAPERED ROUND CONCRETE POST TOP POLE 9.1M (30")
SL-119	TAPERED ROUND CONCRETE POLE 9.9M (32.5')
SL-120	TAPERED ROUND CONCRETE POLE 12.2M (40')
SL-121	TAPERED ROUND CONCRETE POLE 12.9 (42.5')
SL-122	TAPERED ROUND CONCRETE POLE 15.2M (50')
SL-123	DECORATIVE FLUTED OCTAGONAL (POST TOP) POLE 5.3M (17.5")
SL-124	DECORATIVE OCTAGONAL (POST TOP) POLE 6M (19.6')
SL-125	TAPERED OCTAGONAL (POST TOP) POLE 6.1M (20')
SL-126	TAPERED OCTAGONAL POLE 6.1M (20')
SL-127	TAPERED OCTAGONAL POLE 9.9M (32.5')
SL-128	DECORATIVE OCTOGONAL POLE 7.6M (25')
SL-129	DECORATIVE OCTOGONAL POLE 8.2M (27')
SL-130	DECORATIVE FLUTED OCTAGONAL POLE 9.75M (32')
SL-131	DECORATIVE MULTI-UTILITY POLE 9.9M (32.5')
SL-132	DECORATIVE OCTAGONAL POLE 11.1M (36.5')
SL-133	POLE ASSEMBY WALKWAY/PATHWAY LIGHTING 6.1M (20')

## FENCING AND RETAINING WALLS

FRW-101	CHAIN LINK SECURITY FENCE
FRW-102	ACCOUSTIC WOOD FENCE
FRW-103	PRIVACY WOOD FENCE
FRW-104	ACCOUSTIC/PRIVACY FENCE NOTES
FRW-105	PEDESTRIAN/BICYCLE HAND RAIL
FRW-106	FENCE TYPES & PLACEMENT



FILE: C:\Infrastructure Delivery\Infrastructure Programming\PMO\City Standards\Design Criteria\2020-21\City Standards Update\Folder\Co\StandardDrawings\_CAD\_2021\G-102 - Legend of Symbols.dwg

WATER	SEWER	ROAD						
<p>--- (size) --- W --- EXISTING WATERMAIN</p> <p>_____ (size) WATERMAIN _____ PROPOSED WATERMAIN (UP TO 675mmØ)</p> <p>_____ (size) WATERMAIN _____ PROPOSED WATERMAIN (OVER 675mmØ)</p> <p>_____ (size) VC/VB _____ VALVE CHAMBER / IN BOX</p> <p>_____ (size) AV _____ AIR VALVE IN CHAMBER</p> <p>_____ (size) DV _____ DRAIN VALVE IN CHAMBER</p> <p>_____ HYD _____ HYDRANT &amp; VALVE IN BOX</p> <p>_____ CS _____ CURB STOP</p> <p>_____ → _____ REDUCER</p> <p>_____   _____ PLUG</p> <p>_____ } _____ CAP</p> <p>_____ [ _____ CHECK VALVE</p> <p>_____ [ _____ PRESSURE REDUCING VALVE</p>	<p>--- (size) --- SAN/STM --- EXISTING SANITARY / STORM SEWER</p> <p>_____ (size) SANITARY/STORM SEWER _____ PROPOSED SEWER (UP TO 675mmØ)</p> <p>_____ (size) SANITARY/STORM SEWER _____ PROPOSED SEWER (OVER 675mmØ)</p> <p>_____ (size) FDC _____ FOUNDATION DRAIN COLLECTOR</p> <p>--- (size) --- MH --- EXISTING MAINTENANCE HOLE</p> <p>_____ (size) MH _____ PROPOSED MAINTENANCE HOLE</p> <p>--- (size) --- EXISTING DUAL MAINT. HOLE</p> <p>_____ (size) --- PROPOSED DUAL MAINT. HOLE</p> <p>--- □ CB --- EXISTING CATCHBASIN</p> <p>_____ ■ CB _____ PROPOSED CATCHBASIN</p> <p>--- □ DCB --- EX. DOUBLE CATCHBASIN</p> <p>_____ ■ DCB _____ PR. DOUBLE CATCHBASIN</p> <p>--- FM (size) --- PS --- FORCE MAIN &amp; PUMPING STATION</p> <p>--- (size) --- CB/MH --- CATCHBASIN MH</p> <p>_____ CONC. ENCASUREMENT</p>	<p>/// /// /// REMOVAL SYMBOL</p> <p>===== CURB &amp; GUTTER OR CONCRETE CURB</p> <p>_____ (width) C.S.W. _____ CONCRETE SIDEWALK</p> <p>_____ (height &amp; type) _____ FENCE</p> <p>_____ (type) _____ GUIDE RAIL</p> <p>_____ PROPERTY LINE / STREET LINE</p> <p>===== DITCH / SWALE</p> <p>===== EXISTING CULVERT</p> <p>● S/MB SIGN / MAIL BOX</p> <p>HP/BP/TP/LP/TL ● HP HYDRO POLE/BELL POLE TIE POLE/LIGHT POLE TRAFFIC LIGHT</p>						
<b>GENERAL</b>		<b>UNDERGROUND UTILITIES</b>						
<p>↳ CHANGE OF ROAD GRADE (PROFILE DRAWING)</p> <p>↳ CHANGE IN HORIZONTAL DIRECTION OF WATERMAIN (PROFILE DRAWING)</p> <p>△ TB CONCRETE THRUST BLOCK</p> <p>■ FIB/SIB/RIB PROPERTY BAR</p> <p>BM(number) [ ] BENCH MARK (description, location, elevation in notes)</p> <p>BH(number) [ ] BORE HOLE</p>		<p>--- G --- GAS MAIN</p> <p>_____ B _____ BELL CABLE/CONDUIT</p> <p>_____ H _____ HYDRO CABLE</p> <p>_____ B &amp; H _____ BELL &amp; HYDRO (COMMON TRENCH)</p> <p>===== PROPOSED CULVERT</p> <p>LENGTH DIAMETER GAUGE</p>						
		<table border="1" style="width: 100%; border-collapse: collapse;"> <tr> <td style="width: 5%; text-align: center;">2.</td> <td style="width: 85%;"></td> <td style="width: 10%;"></td> </tr> <tr> <td style="text-align: center;">1.</td> <td style="text-align: center;">REVISIONS</td> <td style="text-align: center;">DATE</td> </tr> </table>	2.			1.	REVISIONS	DATE
2.								
1.	REVISIONS	DATE						
		<p style="text-align: center;"><b>VAUGHAN</b></p>						
		<p style="text-align: center;">CITY OF VAUGHAN ENGINEERING STANDARD</p>						
		<p style="text-align: center;"><b>LEGEND OF SYMBOLS</b></p>						
		<p>NOT TO SCALE      DESIGNED: _____</p> <p>REVISION: _____      DATE: DEC. 2020</p>						
		<p>STD. DWG. <b>G - 102</b></p>						

ABUTMENT	ABUT.	FACE OF CURB	F/C	OBVERT	OBV.	SPIRAL TO CURVE	S.C.
ALLOWANCE	ALL'CE	FLOOR	FLR.	ORIGINAL GROUND	O.G.	SPIRAL TO TANGENT	S.T.
AMERICAN SOCIETY FOR TESTING & MATERIALS	A.S.T.M	FOOTING	FTG.	OUTSIDE DIAMETER	O.D.	SQUARE	SQ.
APARTMENT	A.P.T.	FORESIGHT	F.S.			STANDARD IRON BAR	S.I.B.
APPROVED	APP'D	FOUNDATION	FDN.			STANDARD STRENGTH	S.S.
ASBESTOS CEMENT	A.C.	FRAME	FR.			STATION	STA.
ASPHALT	ASPH.			PAVEMENT	PAV'T	STOP OR STREET	ST.
AVERAGE ANNUAL DAILY TRAFFIC	A.A.D.T.	GALVANIZED	GALV.	PERSONS PER HECTARE	P/Ha	STOPPING SIGHT DISTANCE	S.S.D.
		GARAGE	GAR.	POINT	PT.	STORM	STM.
		GAS	G.	POINT OF INTERSECTION	P.I.	STOREY	STY.
		GAUGE	GA.	POINT OF CURVE	P.C.	STREET LINE	S/L
		GEODETIC BENCH MARK	G.B.M.	POLYVINYL CHLORIDE	P.V.C.	STRUCTURE	STR.
		GRADE OR GRAVEL	G.R.	PRESSURE REDUCING VALVE	P.R.V.	STUCCO	STUC.
		GRANULAR	GRAN.	PROPERTY LINE	P or P/L	SUBDIVISION	SUBD'N
		GUIDE RAIL	G.R.	PUMPING STATION	P.S.	SUBDIVIDER	SUBD'R
BACK FILL	B'FILL						
BACKSIGHT OR BUS STOP	B.S.						
BASEMENT	BMNT.						
BEDDING	BED.						
BEGINNING OF CURVE	B.C.						
BEGINNING OF VERTICLE CURVE	B.V.C.						
BELL TELEPHONE	B.						
BELL TELEPHONE POLE	B/P			QUANTITY	QTY.	TANGENT	TAN.
BENCH MARK	B.M.	HECTARE	HA.			TANGENT TO SPIRAL or TAPPING SLEEVE	T.S.
BOULEVARD	BLVD.	HIGH POINT	H.P.			TECHNICAL	TECH.
BUILDING	BLDG.	HIGH WATER LEVEL	H.W.L.			TELEPHONE POLE	T/P
		HIGHWAY	HWY.	RADIUS	R. or RAD.	TOWNSHIP	TWP.
		HORIZONTAL	HOR.	RAILWAY	RWY.	TRAFFIC WARNING LIGHT	TWL
		HOT LAID	H.L.	REGISTERED PLAN	R.P.	TRANSFORMER	TRANS.
		HOT MIX	H.M.	REINFORCED	REINF.	TURNING POINT	T.P.
		HYDRANT & VALVE	H. & V.	RESIDENTIAL	RES.	TYPICAL	TYP.
		HYDRO	H.	REVISION	REV.		
		HYDRO POLE	H. / P.	RIGHT	RT.		
				RIGHT OF WAY	R.O.W.		
				ROAD	RD.	VALVE IN BOX	V.B.
				ROUND IRON BAR	R.I.B.	VALVE IN CHAMBER	V.C.
CHECK VALVE	C.V.	INDUSTRIAL	IND.			VELOCITY	VEL.
CANADIAN NATIONAL RAILWAY	C.N.R.	INSIDE DIAMETER	I.D.			VERTICAL	VERT.
CANADIAN PACIFIC RAILWAY	C.P.R.	INSTRUMENT	INSTR.	SAFE PASSING SIGHT DISTANCE	S.P.S.D.	VERTICAL POINT OF INTERSECTION	V.P.I.
CAST IRON	C.I.	INSULATED	INS.	SAFE STOPPING SIGHT DISTANCE	S.S.S.D.	VITRIFIED	VT.
CATCH BASIN	C.B.	INTERMEDIATE SIGHT	I.S.	SAND	SA.	VOLUME	VOL.
CATCH BASIN MAINTENANCE HOLE	C.B.M.H.	INVERT	INV.	SANITARY	SAN.	VAUGHAN LIGHT CONCRETE POLE	VLCP.
CENTRE TO CENTRE	C./C. or O.C.	IRON BAR	I.B.	SECTION	SECT.	VAUGHAN LIGHT HYDRO POLE	VLHP.
CENTRE LINE	C/L			SEWAGE TREATMENT PLANT	S.T.P.	VAUGHAN LIGHT WOOD POLE	VLWP.
CHAIN LINK FENCE	C.L.F.			SEWER	SEW.	VAUGHAN LIGHT BELL POLE	VLBP.
CHECKED	CHK'D			SHEET	SH.	VAUGHAN LIGHT PEDESTAL	VLP.
CLASS or CLAY	CL.			SIDEWALK	S/W	VAUGHAN LIGHT HANDWELL	VLH.
CLEAN OUT	C.O.			TRAFFIC SIGNAL	TS		
COMMERCIAL	COMM.			SOUTH OR SUPERELEVATION	S.		
CONCESSION	CONC.			SPECIFICATION	SPEC.	WALKWAY	W/W
CHORD	CH.					WATER LEVEL	W.L.
CORNER	COR.					WATER SERVICE VALVE	W.V.
CORREGATED STEEL	C.S.					WATERMAIN	W.M.
CUBIC	CU.	KILOPASCALS	K.P.S.			WEST	W
CULVERT	CULV.						
CURB AND GUTTER	C. & G.						
CURVE TO SPIRAL or CURB STOP	C.S.						
		LEFT	LT.				
		LENGTH	LEN.				
DEGREE OF CURVE	D.	LENGTH OF VERTICAL CURVE	L.V.C.				
DEPARTMENT	DEPT.	LIGHT STANDARD	L.S.				
DIAMETER	DIA.	LITRE	l				
DISTANCE	DIST.	LITRE PER SECOND	l/s				
DIVISION	DIV.	LOW POINT	L.P.				
DRAWING	DWG.	LOW WATER LEVEL	L.W.L.				
DRIVEWAY	DWY.						
DUCTILE IRON	D.I.						
		MAINTENANCE HOLE	M.H.				
EACH	EA.	MAXIMUM	MAX.				
END OF CURVE	E.C.	MEGAPASCALS	M. Pa.				
EAST OF EXTERNAL	E.	METRE	m				
EDGE OF PAYMENT	E.P.	MILLIMETRES	mm				
ELECTRIC	ELEC.	MILLIMETRES PER SECOND	m/s				
ELECTRICAL MAINTENANCE HOLE	EMH.	MINISTRY OF TRANSPORTATION	M.T.O.				
ELEVATION	EL.	OF ONTARIO	MIN.				
END OF VERTICAL CURVE	E.V.C.		MUN.				
ENGINEER	ENG.	MINIMUM					
ENTRANCE	ENT.	MUNICIPAL					
ESTIMATE	EST.						
EXISTING	EXIST.						
EXTRA STRENGTH	E.S.						
		NORTH	N.				
		NOT TO SCALE	N.T.S.				
		NUMBER	No.				

4.		
3.		
2.		
1.		
	REVISIONS	DATE



CITY OF VAUGHAN ENGINEERING STANDARD

ABBREVIATIONS

NOT TO SCALE      DESIGNED: \_\_\_\_\_  
 REVISION: \_\_\_\_\_      DATE: DEC. 2020

STD. DWG.  
**G - 103**



FILE: O:\Infrastructure Delivery\Infrastructure Programming\PMO\City Standards\Design Criteria 2020-21\City Standards Update Folder\ColStandardDrawings\_CAD\_2021\G-104 -Geodetic Control Survey Marker TypeA.dwg

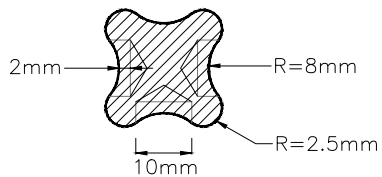
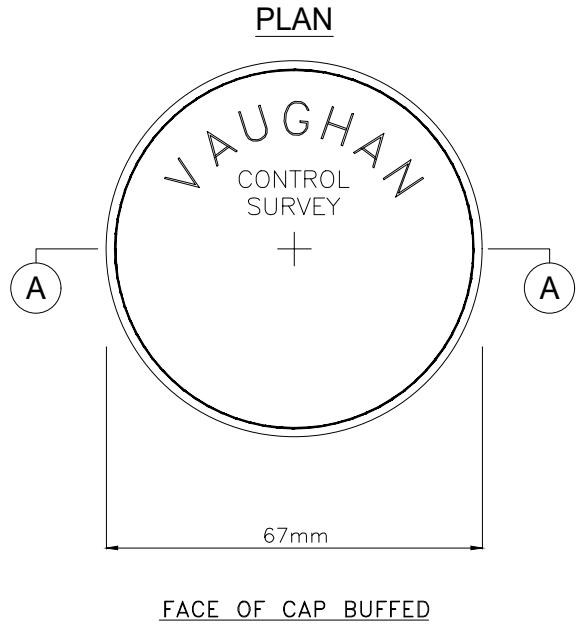

**SECTION B-B**

MATERIAL - BRASS OR BRONZE WITH NOT LESS THAN 83% COPPER CONTENT. B METAL 0.78 lbs.

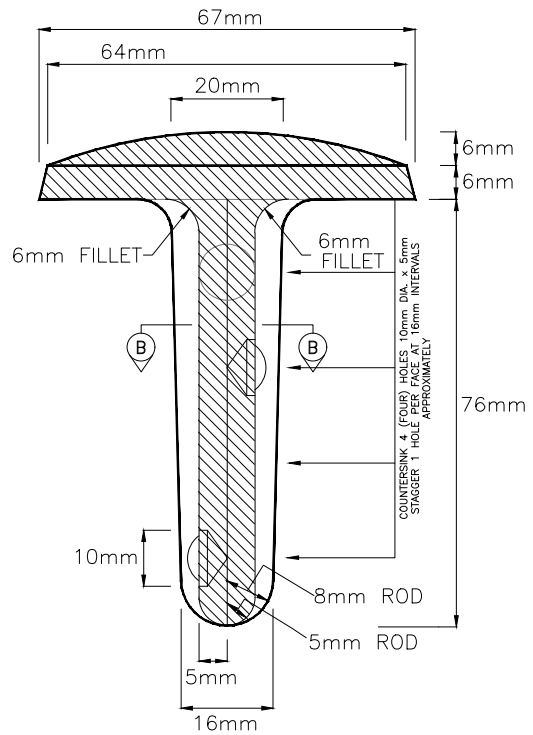

**SECTION A-A**

**NOTE**

1. REFER TO DRAWING STD. G-106 FOR ENGRAVING / STAMPING DETAILS.

**mm** DIMENSIONS IN MILLIMETRES EXCEPT AS NOTED

4.		
3.		
2.		
1.		
REVISIONS		DATE



CITY OF VAUGHAN ENGINEERING STANDARD

**GEODETIC CONTROL SURVEY MARKER - TYPE A**

NOT TO SCALE DESIGNED: \_\_\_\_\_  
 REVISION: \_\_\_\_\_ DATE: DEC. 2020

STD. DWG.  
**G - 104**

FILE: O:\Infrastructure Delivery\Infrastructure Programming\PMO\City Standards\Design Criteria 2020-21\City Standards Update\Folder\Col\StandardDrawings\_CAD\_2021\C-105 - Geodetic Control Survey Marker Type B.dwg

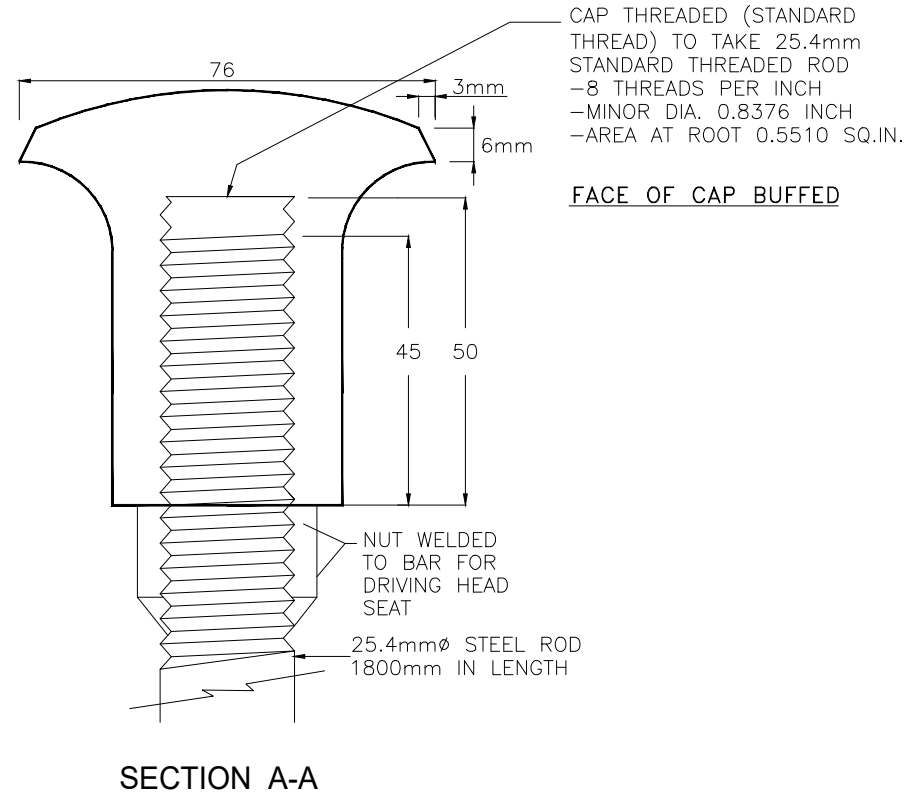
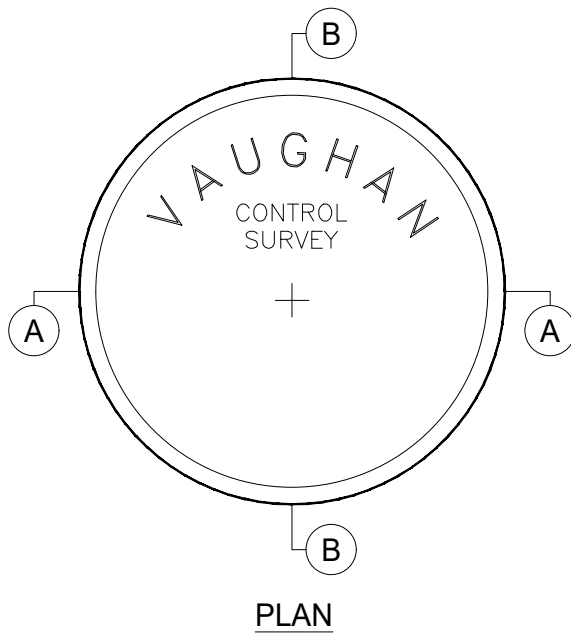

CAP THREADED (STANDARD THREAD) TO TAKE 25.4mm STANDARD THREADED ROD  
 -8 THREADS PER INCH  
 -MINOR DIA. 0.8376 INCH  
 -AREA AT ROOT 0.5510 SQ.IN.  
**FACE OF CAP BUFFED**

NUT WELDED TO BAR FOR DRIVING HEAD SEAT  
 25.4mmØ STEEL ROD 1800mm IN LENGTH

**NOTE**

1. REFER TO DRAWING STD. G-106 FOR ENGRAVING / STAMPING DETAILS.

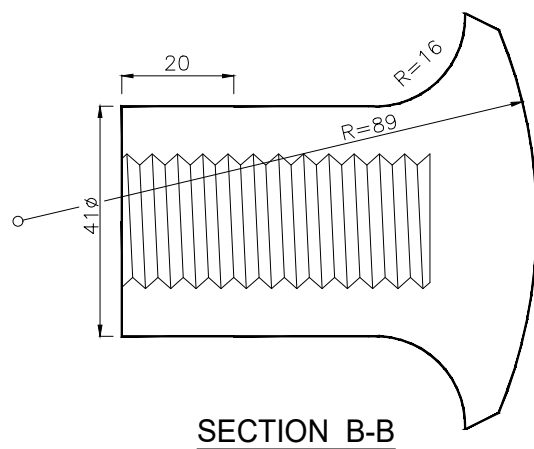

**MATERIAL - BRASS OR BRONZE WITH NOT LESS THAN 83% COPPER CONTENT. B METAL 2 32 lbs.**

4.		
3.		
2.		
1.		
REVISIONS		DATE



CITY OF VAUGHAN ENGINEERING STANDARD

**GEODETIC CONTROL SURVEY MARKER - TYPE B**

NOT TO SCALE DESIGNED: \_\_\_\_\_

REVISION: \_\_\_\_\_ DATE: DEC. 2020

STD. DWG.

**G - 105**

**mm** DIMENSIONS IN MILLIMETRES EXCEPT AS NOTED

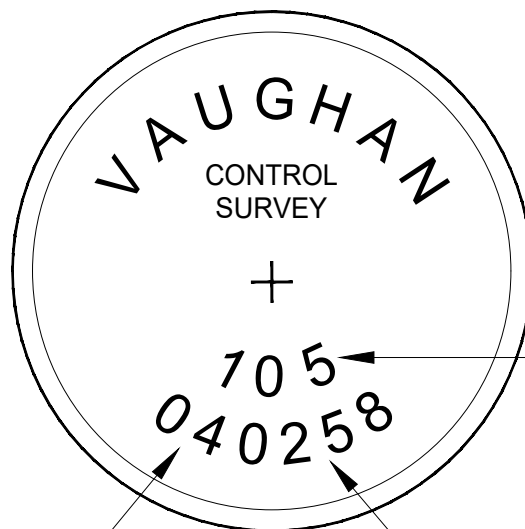

2 DIGIT YEAR

CITY CODE NUMBER

4 DIGIT MONUMENT NUMBER

PLAN VIEW

LETTER STYLE - STANDARD GOTHIC

LETTER SIZE - 5mm STROKE CENTRE TO STROKE CENTRE;  
6mm EDGE TO EDGE FOR OUTER INSCRIPTION  
3mm STROKE CENTRE TO STROKE CENTRE;  
3mm EDGE TO EDGE FOR INNER INSCRIPTION

LETTER DEPTH - 1mm

LETTER TAPERED 20° PER SIDE

4.		
3.		
2.		
1.		
REVISIONS		DATE



CITY OF VAUGHAN ENGINEERING STANDARD

GEODETIC CONTROL  
SURVEY MARKER ENGRAVING / STAMPING

NOT TO SCALE      DESIGNED: \_\_\_\_\_  
REVISION: \_\_\_\_\_      DATE: DEC. 2020

STD. DWG.  
**G - 106**

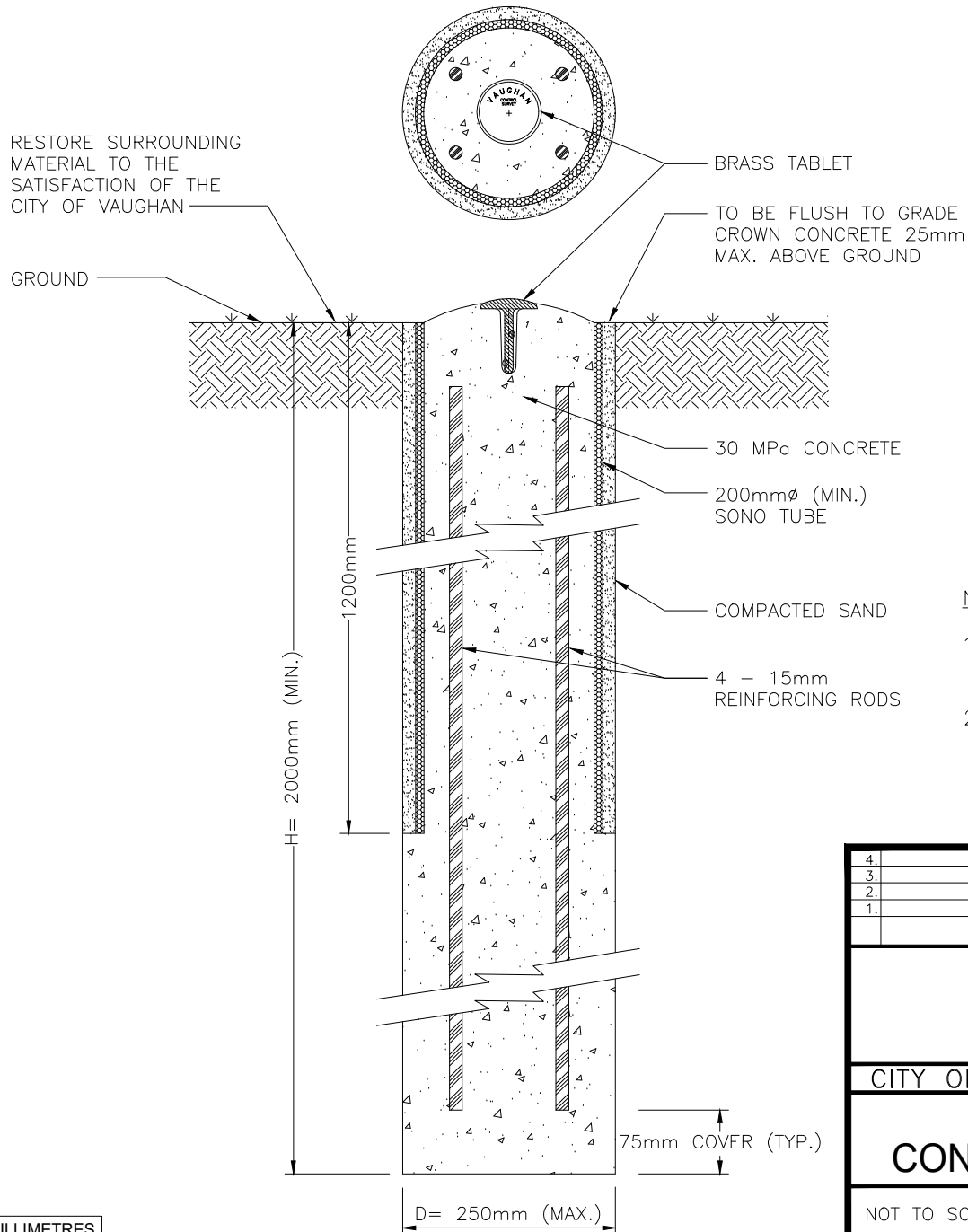

NOTE

1. REFER TO DRAWING STD. G-106 FOR ENGRAVING / STAMPING DETAILS.
2. REFER TO DRAWING STD. G-104 FOR BRASS TABLET DETAILS.

4.		
3.		
2.		
1.		
REVISIONS		DATE



CITY OF VAUGHAN ENGINEERING STANDARD  
**GEODETIC CONTROL  
 CONCRETE SURVEY MARKER**

NOT TO SCALE      DESIGNED: \_\_\_\_\_  
 REVISION: \_\_\_\_\_      DATE: DEC. 2020

STD. DWG.  
**G - 107**

**mm** DIMENSIONS IN MILLIMETRES  
 EXCEPT AS NOTED

FILE: C:\Infrastructure\Delivery\Infrastructure Programming\PMO\City Standards\Design Criteria 2020-21\City Standards Update Folder\CivilStandardsDrawings\_CAD\_2021\G-108 - Project\_Sign.dwg

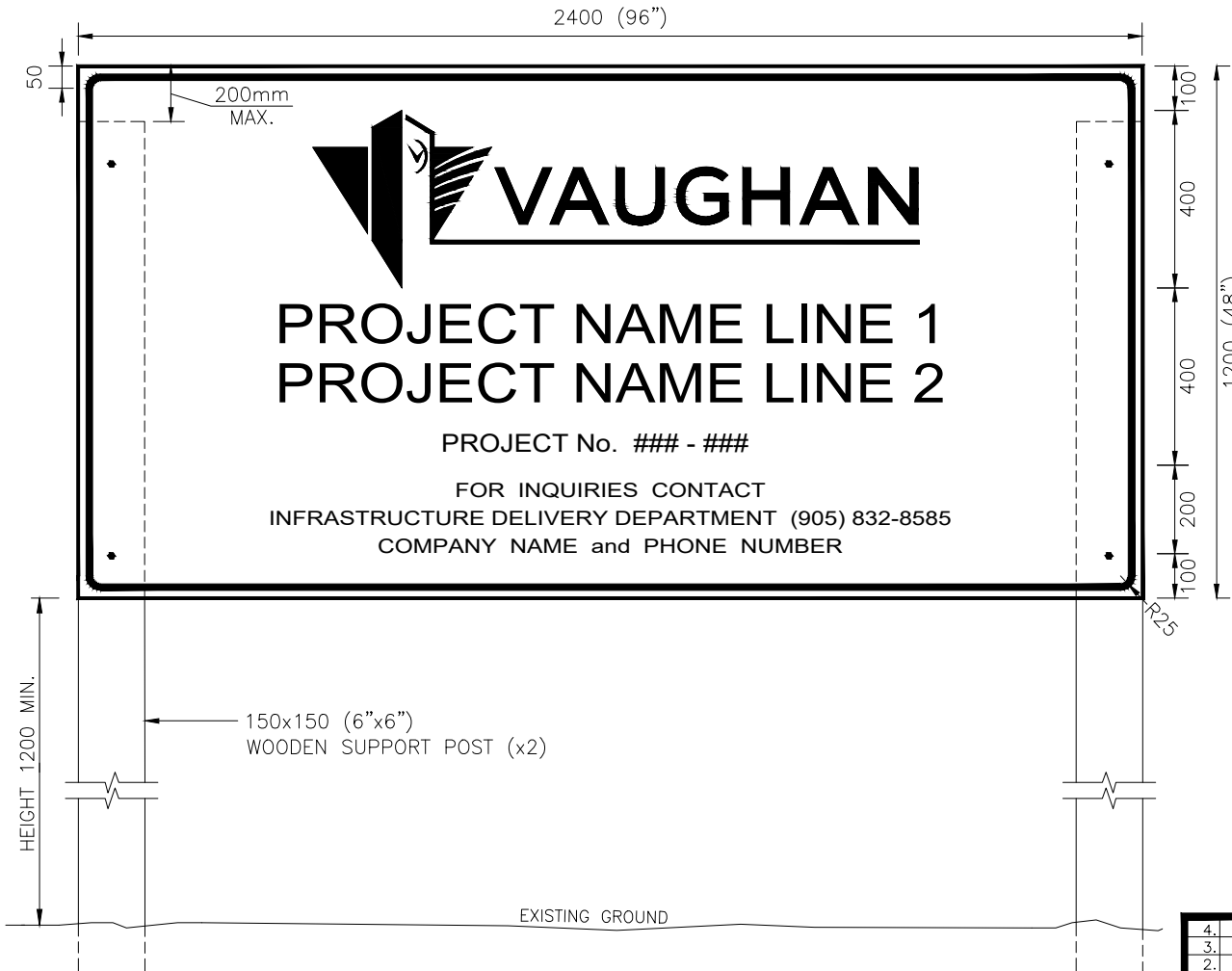

**NOTES**

1. PROJECT TITLE & CONTRACT NUMBER TO BE PROVIDED BY THE CITY.
2. COMPANY NAME & NUMBER TO BE CONFIRMED.
3. MINIMUM 20mm THICK PLYWOOD SIGN.
4. WOODEN SUPPORT POSTS TO BE INSTALLED AS PER OPSD 985.220

**mm** DIMENSIONS IN MILLIMETRES EXCEPT AS NOTED

**SIGN COLOURS & FONTS**

**BACKGROUND:** WHITE

**CITY LOGO:**  
 GRAPHIC AVAILABLE ON CITY WEB SITE  
 PANTONE 376 GREEN  
 PANTONE 294 BLUE

**EDGE STRIPE:**  
 WIDTH-15mm, PANTONE 294 BLUE  
 CORNER RADIUS-25mm

**PROJECT NAME:** (TWO LINES PREFERRED)  
 UNIVERS 65 BOLD-250 pt, PANTONE 294 BLUE, UPPER CASE  
 LINE 1: PRIMARY STREET WHERE WORK IS TAKING PLACE e.g. "MCKENZIE STREET"  
 LINE 2: PROJECT TYPE (PRIMARY WORK) e.g. "WATERMAIN REPLACEMENT"

**CONTRACT NUMBER:** (1 LINE)  
 UNIVERS 55 ROMAN BOLD-115 pt, PANTONE 294 BLUE, UPPER CASE

**CONTACT INFORMATION:** (3 LINES)  
 UNIVERS 55 ROMAN BOLD-90 pt, PANTONE 294 BLUE, UPPER CASE

4.		
3.		
2.		
1.		
REVISIONS		DATE



CITY OF VAUGHAN ENGINEERING STANDARD

**PROJECT SIGN**

NOT TO SCALE      DESIGNED: \_\_\_\_\_  
 REVISION: \_\_\_\_\_      DATE: \_\_\_\_\_ DEC. 2020

STD. DWG.

**G - 108**

Acad File: R:\ENG\DRAWING\Design Std Drawings 2004\B\_Roads\B-3.DWG

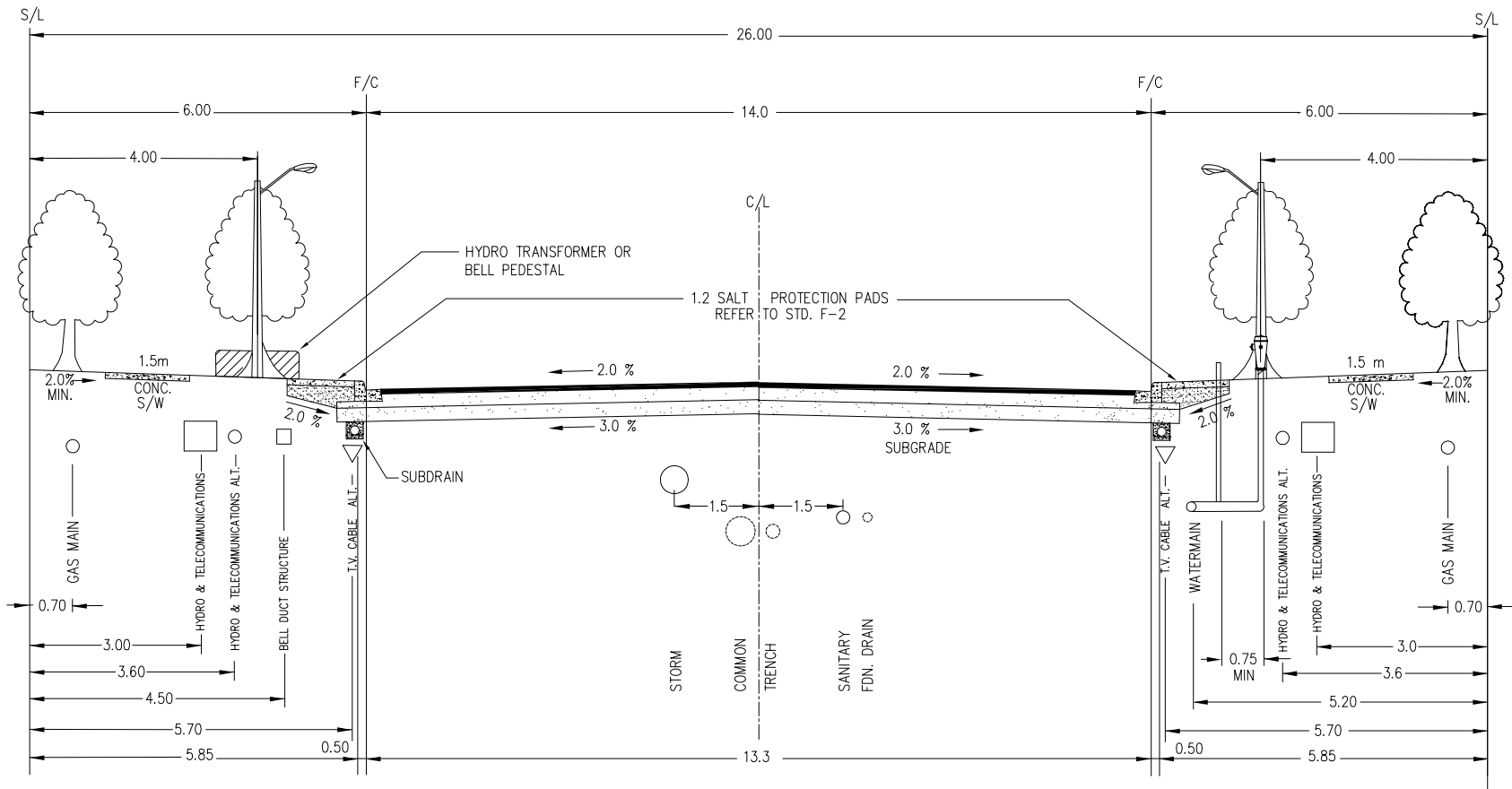

**NOTES**

1. PAVEMENT WIDTH IS DESIGNED TO ACCOMMODATE 4 TRAVEL LANES OR 2 TRAVEL LANES WITH 2 PARKING LANES.
2. PAVEMENT DESIGN SHALL CONFORM TO MINIMUM CITY STANDARDS AND/OR APPROVED GEOTECHNICAL REPORT.
3. ACTIVELY GROWING No. 1 NURSERY SOD TO BE LAID ON 150mm OF TOPSOIL, PROPERLY GRADED AND ROLLED.
4. DEPTH OF COVER ON ALL MUNICIPAL INFRASTRUCTURE SHALL CONFORM TO MINIMUM CITY STANDARDS.

**m** DIMENSIONS IN METRES  
EXCEPT AS NOTED

4.		
3.		
2.		
1.		
REVISIONS		DATE



CITY OF VAUGHAN ENGINEERING STANDARD

**MAJOR COLLECTOR ROAD  
26m R.O.W.**

NOT TO SCALE      DESIGNED: ENG. DEPT.  
 REVISION: \_\_\_\_\_      DATE: MARCH 2004

STD. DWG.  
**B - 3**

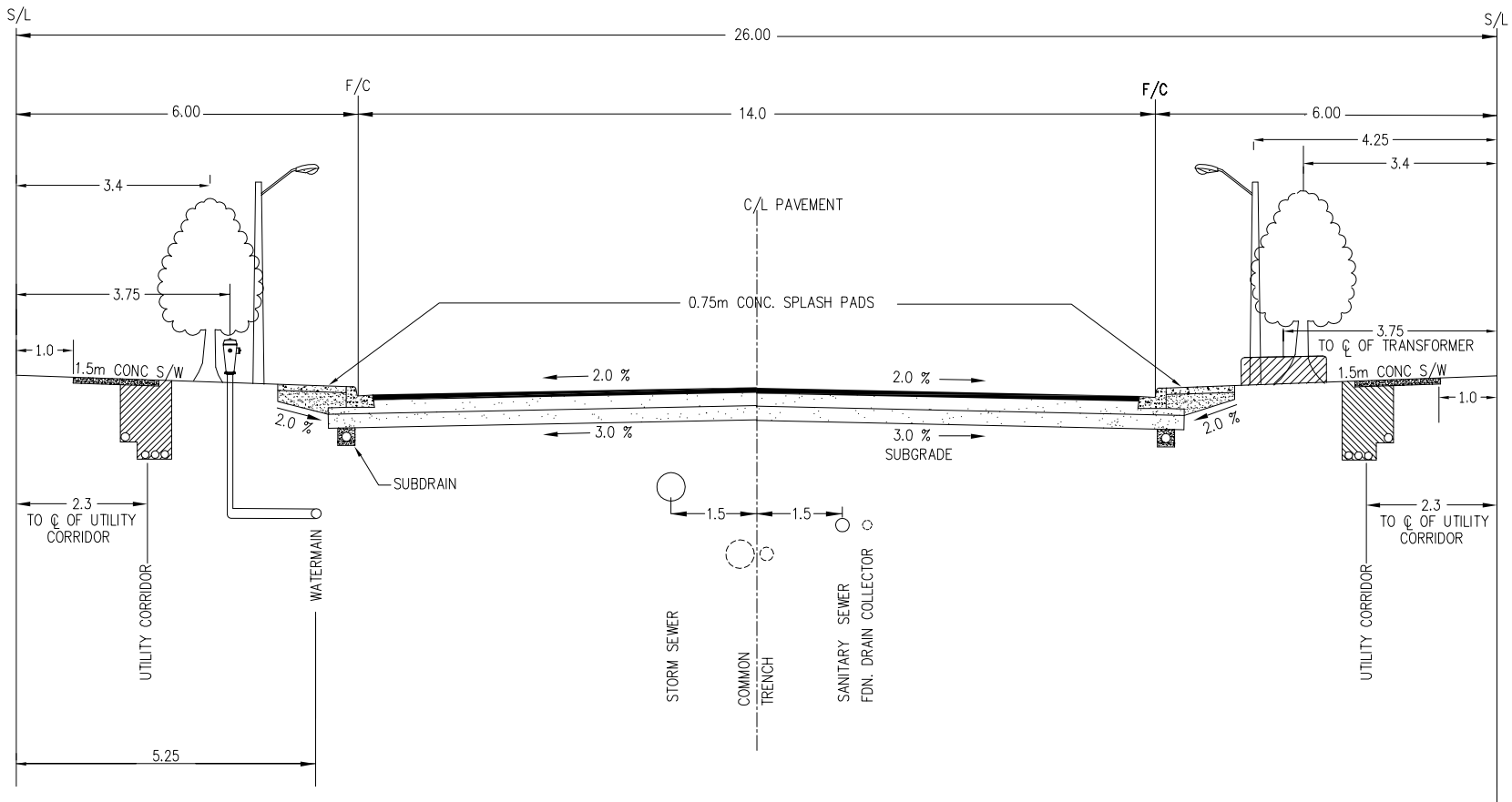

**NOTES**

1. PAVEMENT WIDTH IS DESIGNED TO ACCOMMODATE 4 TRAVEL LANES OR 2 TRAVEL LANES WITH 2 PARKING LANES.
2. PAVEMENT DESIGN SHALL CONFORM TO MINIMUM CITY STANDARDS AND/OR APPROVED GEOTECHNICAL REPORT.
3. ACTIVELY GROWING No. 1 NURSERY SOD TO BE LAID ON 150mm OF TOPSOIL, PROPERLY GRADED AND ROLLED.
4. DEPTH OF COVER ON ALL MUNICIPAL INFRASTRUCTURE SHALL CONFORM TO MINIMUM CITY STANDARDS.

**m** DIMENSIONS IN METRES  
EXCEPT AS NOTED

4.		
3.		
2.		
1.		
REVISIONS		DATE



CITY OF VAUGHAN ENGINEERING STANDARD

**MAJOR COLLECTOR ROAD  
26m R.O.W. - 14m PAVEMENT**

NOT TO SCALE

DESIGNED: ENG. DEPT.

STD. DWG.

REVISION: \_\_\_\_\_

DATE: MARCH 2004

**B - 8**

Job File: \\Va\Departments\Infrastructure\Delivery\Infrastructure Programming\DWG\Civil\Standards\Design\Standards\2020-21\Civil\_Standards\_Update\Roads\Construction\Drawings\2022\18-102 - Minor Collector Road - 24m R.O.W. - Lay-By Lane.dwg

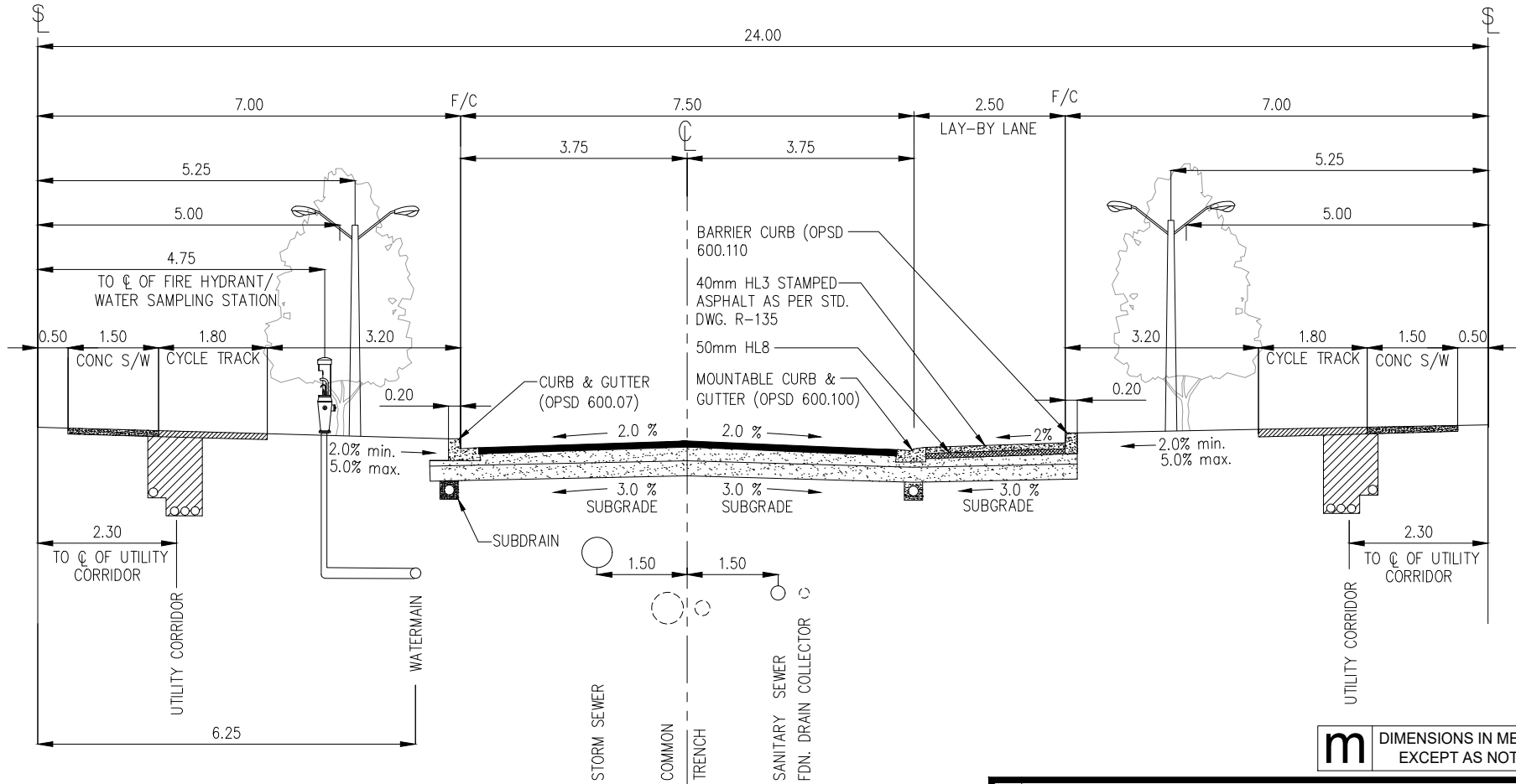

**m** DIMENSIONS IN METRES  
EXCEPT AS NOTED

**NOTES**

1. PAVEMENT DESIGN SHALL CONFORM TO MINIMUM CITY STANDARDS AND/OR APPROVED GEOTECHNICAL REPORT.
2. ACTIVELY GROWING No. 1 NURSERY SOD TO BE LAID ON 150mm OF TOPSOIL, PROPERLY GRADED AND ROLLED.
3. DEPTH OF COVER ON ALL MUNICIPAL INFRASTRUCTURE SHALL CONFORM TO MINIMUM CITY STANDARDS.
4. COLOR AND PATTERN OF CONCRETE UNIT PAVERS TO BE APPROVED BY THE ENGINEERING DEPARTMENT IN CONSULTATION WITH THE URBAN DESIGN DEPARTMENT.
5. REFER TO BIKEWAY TRAFFIC CONTROL GUIDELINES FOR CANADA (LATEST EDITION, TAC & O.T.M., YORK REGION) FOR TYPICAL BICYCLE FACILITY SPECIFICATIONS INCLUDING PAVEMENT MARKING & SIGNAGE AND INTERSECTION APPLICATION.
6. THE DEDIDED CYCLE TRACK WIDTH OF 1.8m SHOULD BE ACCOMMODATED WHERE POSSIBLE
7. WHERE RAISED PLANTER OR VERTICAL OBJECT WILL ABUT THE CYCLE TRACK, 0.5m OF CLEARANCE MUST BE PROVIDED.
8. THE SUBSTITUTION OF SEPARATED PEDESTRIAN AND CYCLING FACILITIES INSTEAD OF COMBINED FACILITIES IS ACCEPTABLE. THE DESIGN OF THE ACTIVE TRANSPORTATION FACILITIES SHOULD BE CONFIRMED WITH CITY STAFF.
9. PARKING PERMITTED WITHIN THE LAY-BY-LANE.

4.		
3.		
2.		
1.		
REVISIONS		DATE



CITY OF VAUGHAN ENGINEERING STANDARD

**MINOR COLLECTOR ROAD  
24m R.O.W. (WITH LAY-BY LANE)**

NOT TO SCALE      DESIGNED: \_\_\_\_\_  
REVISION: \_\_\_\_\_      DATE: \_\_\_\_\_ JAN. 2022

STD. DWG.  
**R - 102**





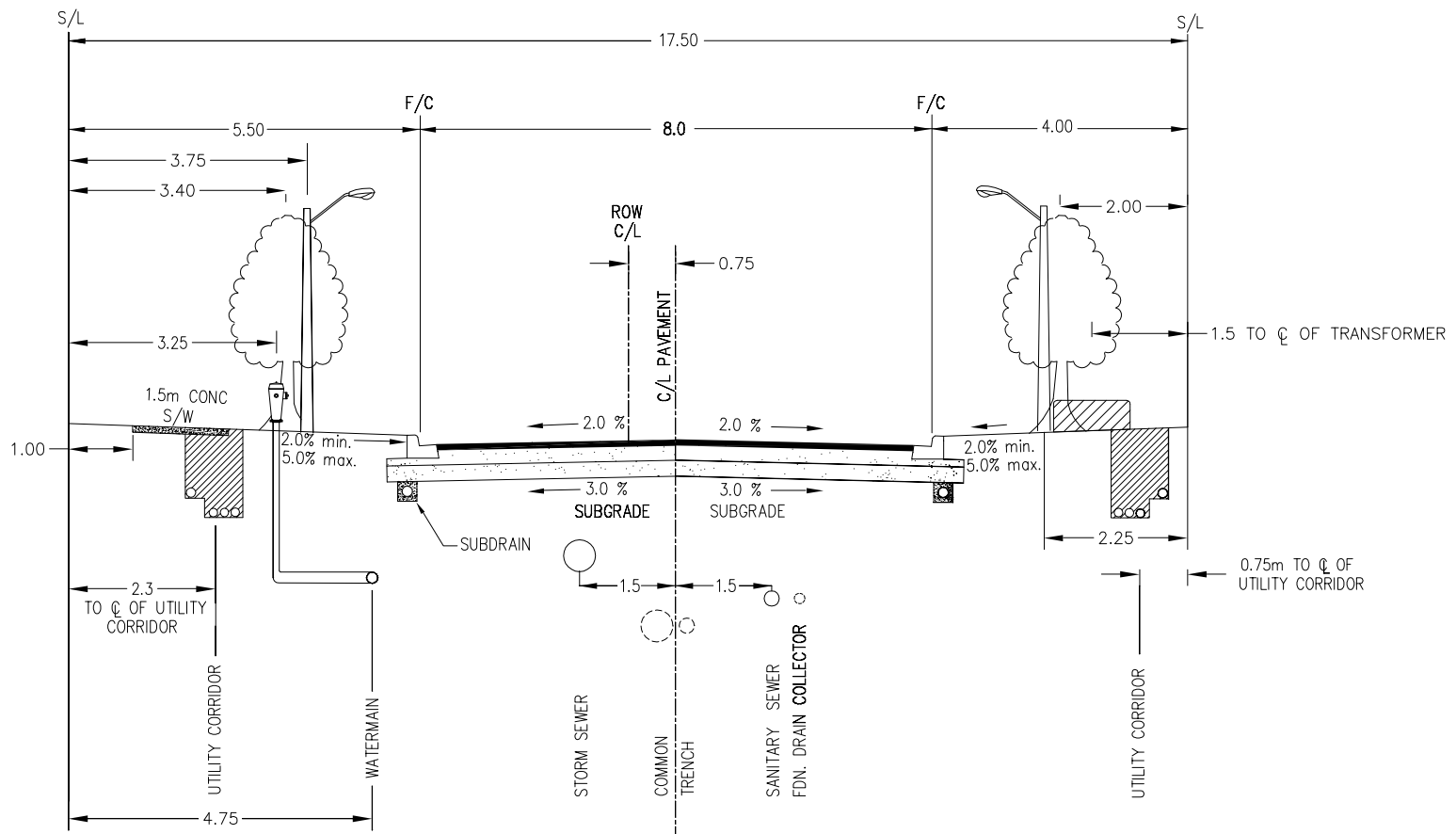

**NOTES**

1. PAVEMENT WIDTH IS DESIGNED TO ACCOMMODATE 2 TRAVEL LANES WITH 1 PARKING LANE.
2. PAVEMENT DESIGN SHALL CONFORM TO MINIMUM CITY STANDARDS AND/OR APPROVED GEOTECHNICAL REPORT.
3. ACTIVELY GROWING No. 1 NURSERY SOD TO BE LAID ON 150mm OF TOPSOIL, PROPERLY GRADED AND ROLLED.
4. DEPTH OF COVER ON ALL MUNICIPAL INFRASTRUCTURE SHALL CONFORM TO MINIMUM CITY STANDARDS.

**m** DIMENSIONS IN METRES  
EXCEPT AS NOTED

4.		
3.		
2.		
1.		
REVISIONS		DATE

**Vaughan**  
*The City Above Toronto*

**ENGINEERING**  
**DEPARTMENT**

CITY OF VAUGHAN ENGINEERING STANDARD

**LOCAL ROAD**  
**17.5 m R.O.W. - 8m PAVEMENT**

NOT TO SCALE      DESIGNED: ENG. DEPT.  
REVISION: \_\_\_\_\_      DATE: MARCH 2004

STD. DWG.  
**B - 12**

Acad File: R:\ENGDRAFT\Design Std Drawings 2004\B\_Roads\B-13.dwg

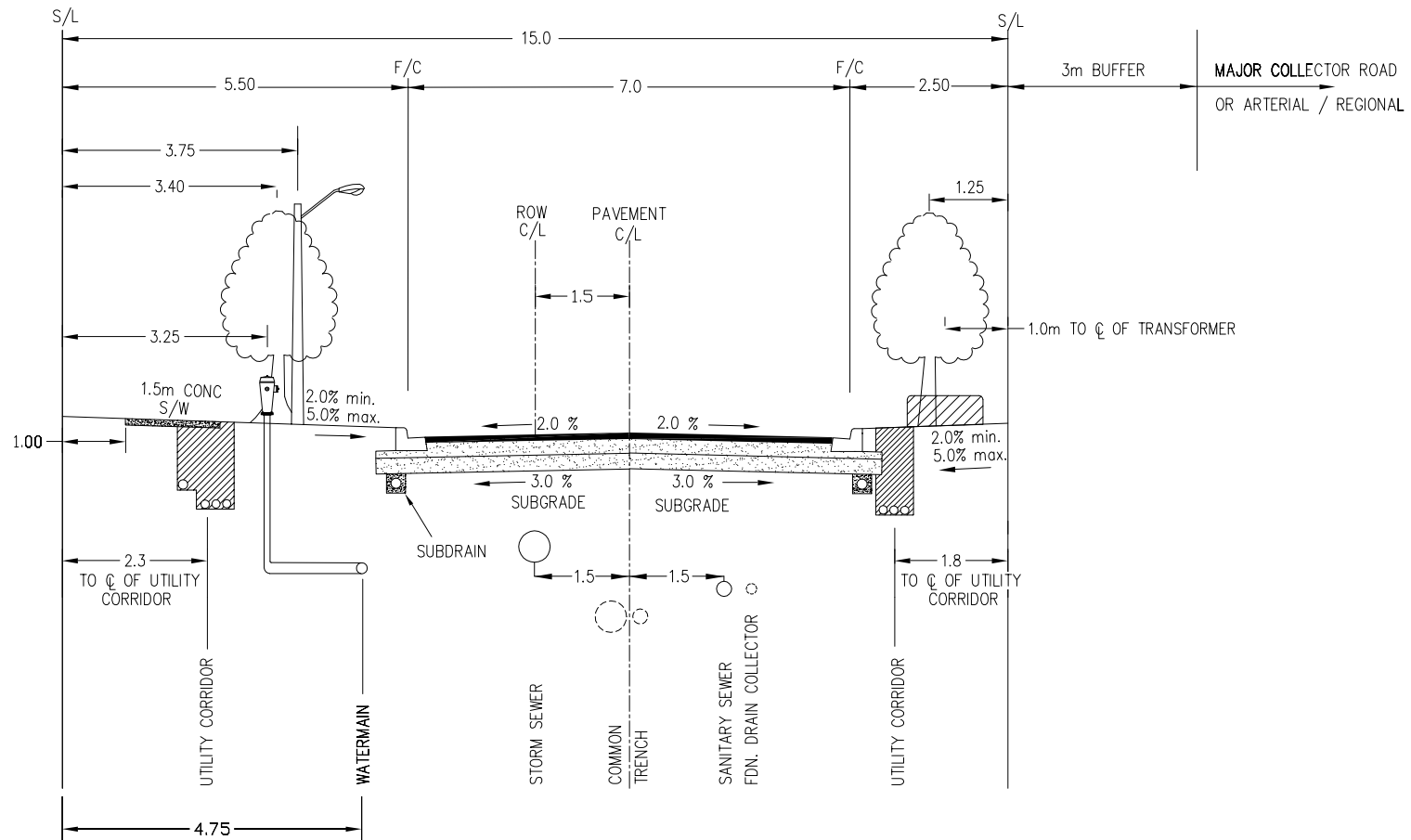

**NOTES**

1. PAVEMENT WIDTH IS DESIGNED TO ACCOMMODATE 2 TRAVEL LANES WITH NO PARKING.
2. PAVEMENT DESIGN SHALL CONFORM TO MINIMUM CITY STANDARDS AND/OR APPROVED GEOTECHNICAL REPORT.
3. ACTIVELY GROWING No. 1 NURSERY SOD TO BE LAID ON 150mm OF TOPSOIL, PROPERLY GRADED AND ROLLED.
4. DEPTH OF COVER ON ALL MUNICIPAL INFRASTRUCTURE SHALL CONFORM TO MINIMUM CITY STANDARDS.
5. BUFFER ROAD SHALL ONLY BE USED ADJACENT TO MAJOR COLLECTOR OR HIGHER CLASSIFICATION ROAD.

**m** DIMENSIONS IN METRES  
EXCEPT AS NOTED

4.		
3.		
2.		
1.		
REVISIONS		DATE
CITY OF VAUGHAN ENGINEERING STANDARD		
<b>BUFFER ROAD</b> <b>15 m R.O.W. - 7m PAVEMENT</b>		
NOT TO SCALE	DESIGNED: <u>ENG. DEPT.</u>	STD. DWG.
REVISION: _____	DATE: <u>MARCH 2004</u>	<b>B - 13</b>

**m** DIMENSIONS IN METRES  
EXCEPT AS NOTED

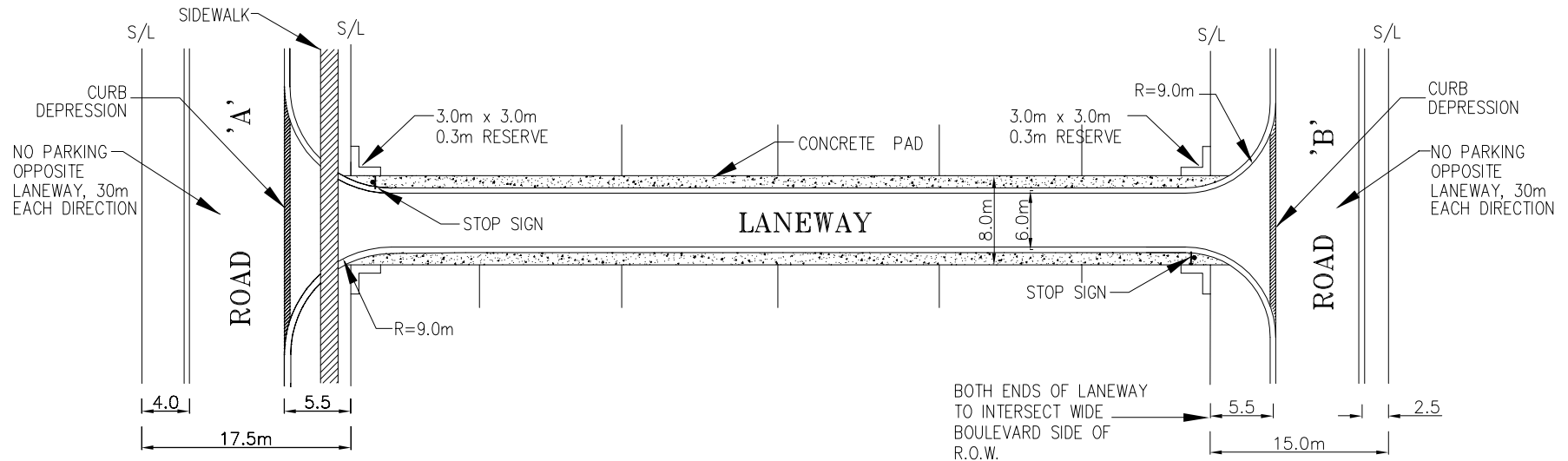
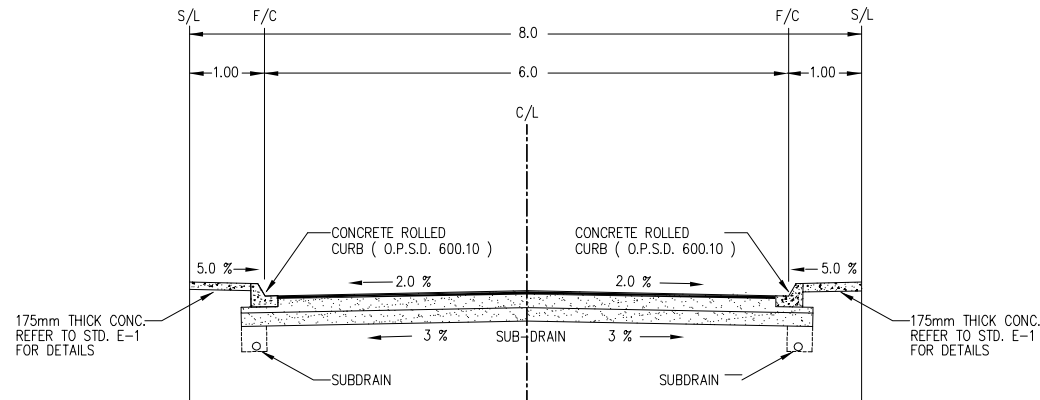

**NOTES**

1. STOP SIGN SIZE 60cm x 60cm INTERSECTING (15.0m/17.5m/20.0m/23.0m) R.O.W.
2. "NO PARKING FIRE ROUTE" SIGNS TO BE INSTALLED AT ENTRY POINTS AND LOCATED 45.0m APART THEREAFTER ( WHENEVER POSSIBLE ).
3. ALL SIGNS TO BE INSTALLED ON U-CHANNEL GALVANIZED STEEL POSTS.
4. STREET NAME SIGNS TO ON 150mm DOUBLE FACED ALUMINUM BLADES (REFLECTORIZED).
5. ALL REGULATORY SIGNS MANUFACTURED USING HIGH INTENSITY SHEETING.
6. LUMINAIRES TO BE PROVIDED ON GARAGES WHERE APPLICABLE.
7. PAVEMENT DEPTH SHALL CONFORM TO MINIMUM CITY STANDARDS AND/OR APPROVED GEOTECHNICAL REPORT.
8. DEPTH OF COVER ON ALL MUNICIPAL INFRASTRUCTURE SHALL CONFORM TO MINIMUM CITY STANDARDS.

4.		
3.		
2.		
1.		
REVISIONS		DATE



CITY OF VAUGHAN ENGINEERING STANDARD

**LANEWAY**  
**8m R.O.W. - 6m PAVEMENT**

NOT TO SCALE      DESIGNED: ENG. DEPT.  
REVISION: \_\_\_\_\_      DATE: MARCH 2004

STD. DWG.  
**B - 14**

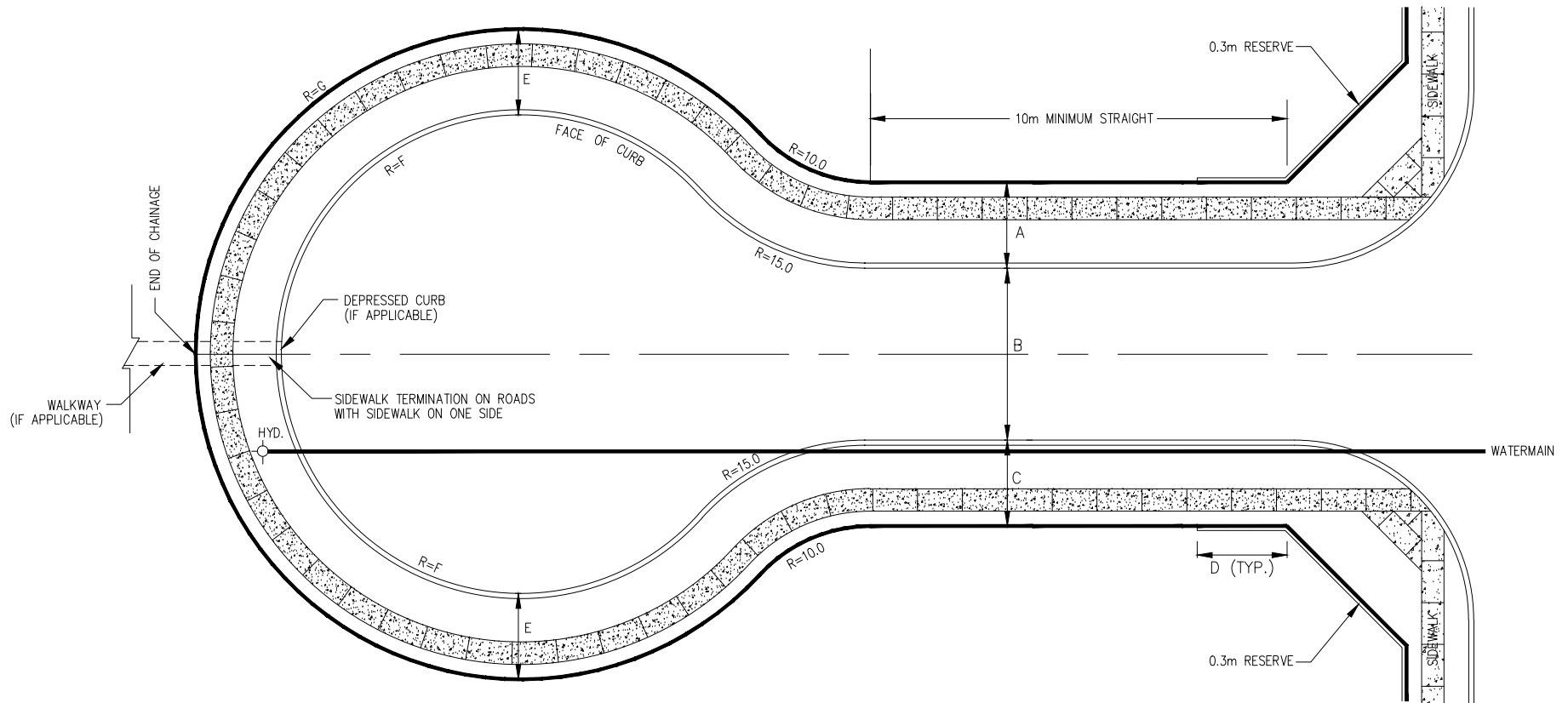

TABLE:

	R.O.W.	A	B	C	D	E	F	G
MINOR COLLECTOR/INDUSTRIAL ROAD	24.0m	5.5	10.5	8.0	6.0*	5.5	16.0	21.5
LOCAL ROAD	17.5m	4.0	8.0	5.5	3.0	5.5	13.25	18.75

**NOTES**

1. AT THE CURB, THERE SHALL BE A MIN. 1.0m BARRIER CURB BETWEEN EVERY DRIVEWAY AROUND THE BULB OF THE CUL-DE-SAC.
2. HYDRANT TO BE LOCATED AT THE END OF THE WATERMAIN, AS CLOSE TO THE END OF THE CUL-DE-SAC AS POSSIBLE.
3. MINIMUM 0.7% GUTTER GRADE.
4. MAXIMUM 40 UNITS ON CUL-DE-SAC.

**m** DIMENSIONS IN METRES  
EXCEPT AS NOTED

4.		
3.		
2.		
1.	*REVISED/UPDATED TABLE	11/24
	REVISIONS	DATE

CITY OF VAUGHAN ENGINEERING STANDARD

**CUL-DE-SAC**

NOT TO SCALE	DESIGNED: _____	STD. DWG.
REVISION: 1	DATE: JUN. 2021	<b>R - 107</b>

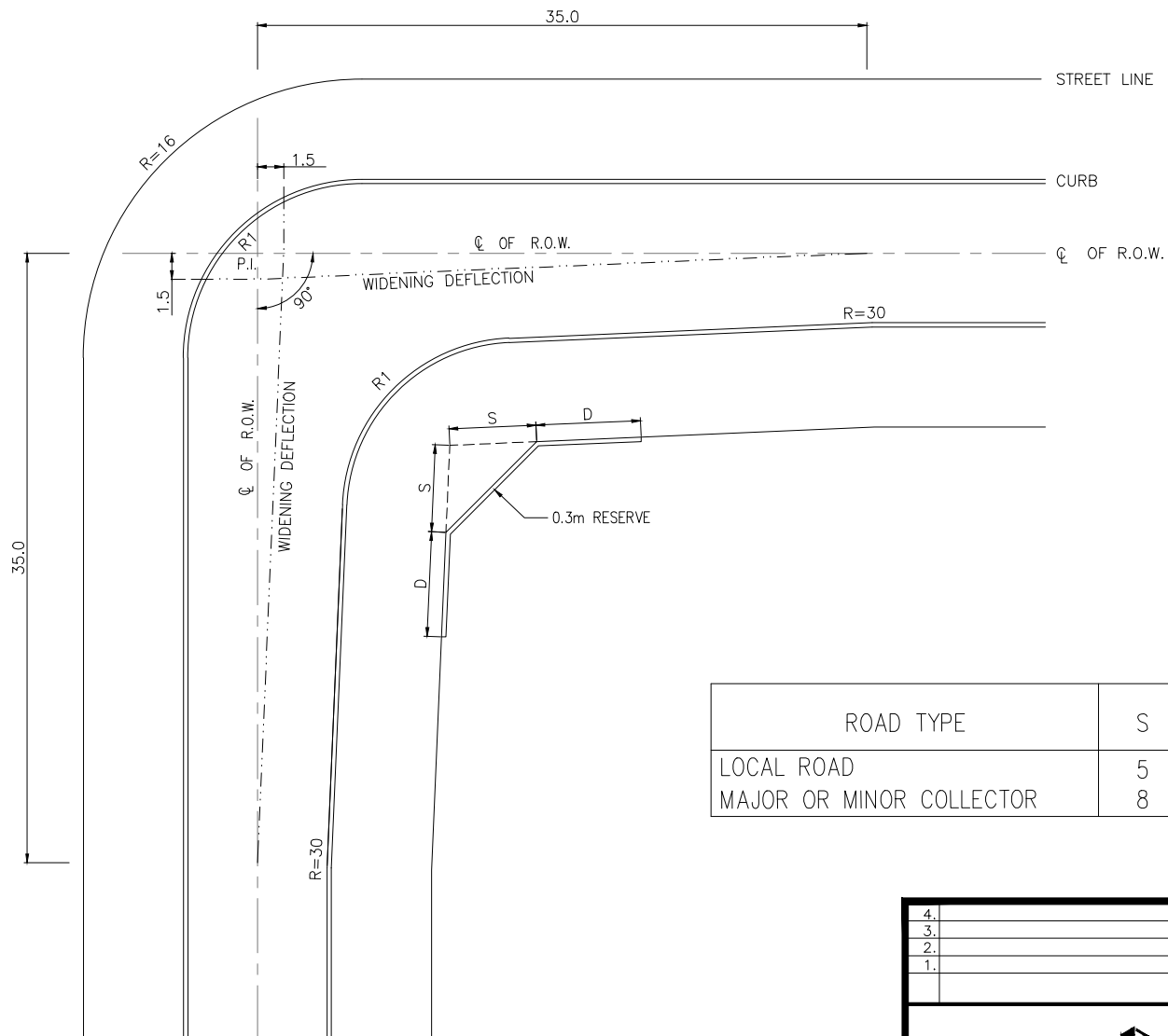

ROAD TYPE	S	D	RI
LOCAL ROAD	5	-	10
MAJOR OR MINOR COLLECTOR	8	6	12

**NOTES**

1. MINIMUM 0.7% GUTTER GRADE.
2. BOULEVARD WIDTHS TO BE MAINTAINED AS PER ROAD CROSS-SECTION DETAILS.
3. APPLICABLE ONLY TO ROADS BELOW MAJOR COLLECTOR STATUS.
4. AT THE CURB ON THE OUTSIDE OF THE BEND THERE SHALL BE A MINIMUM 1.0m SPACE BETWEEN EVERY SECOND DRIVEWAY.

**m** DIMENSIONS IN METRES  
EXCEPT AS NOTED

4.		
3.		
2.		
1.		
REVISIONS		DATE



CITY OF VAUGHAN ENGINEERING STANDARD

**ANGLE BEND**

NOT TO SCALE      DESIGNED: \_\_\_\_\_  
 REVISION: \_\_\_\_\_      DATE: DEC. 2020

STD. DWG.  
**R - 108**

FILE: C:\Users\quidiemop\CITY OF VAUGHAN\City Standards - General\Design Criteria 2024\Dev - Standards\CAD\R-109 - Horizontal Curves.dwg

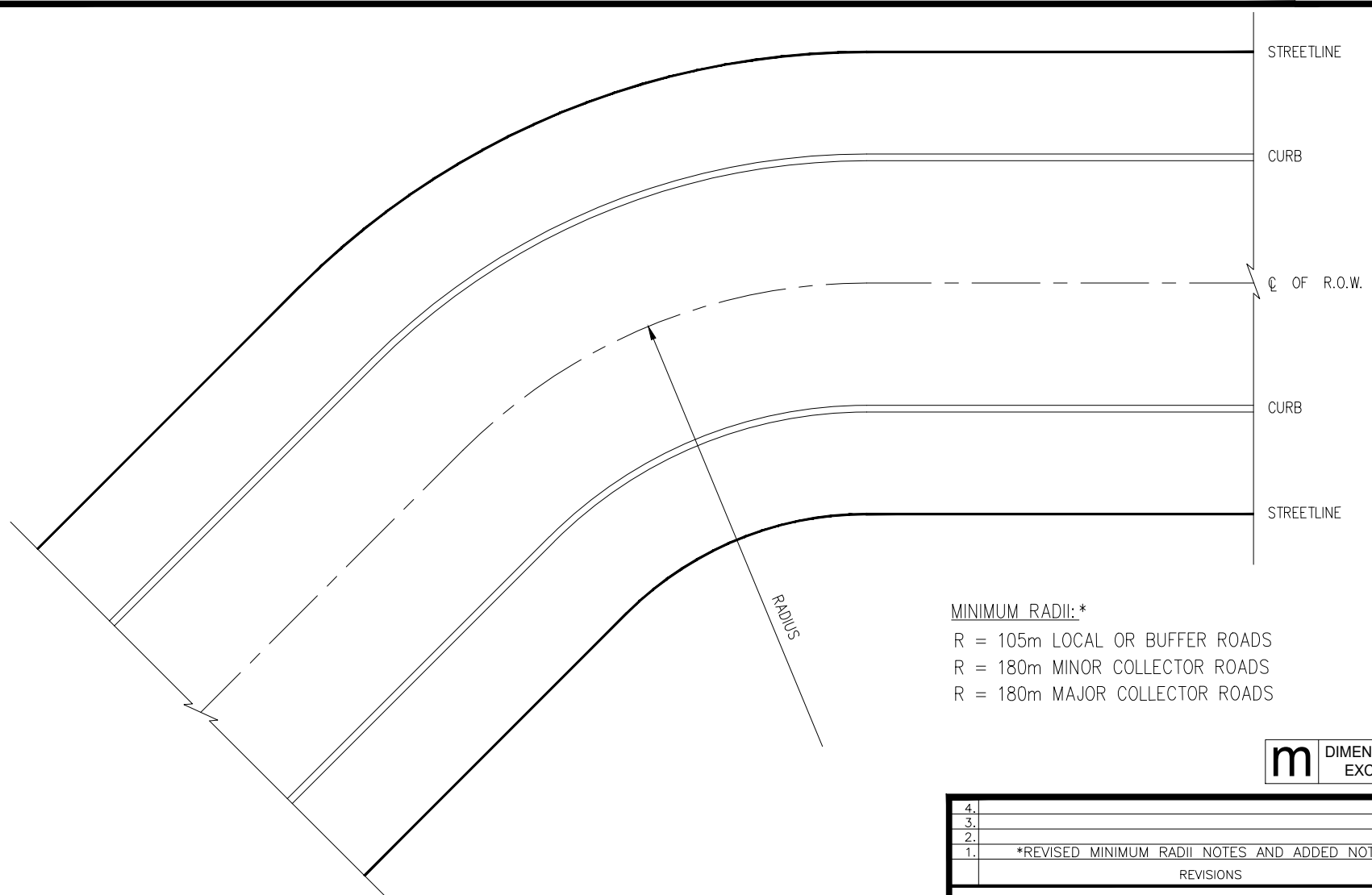

**MINIMUM RADII:\***  
 R = 105m LOCAL OR BUFFER ROADS  
 R = 180m MINOR COLLECTOR ROADS  
 R = 180m MAJOR COLLECTOR ROADS

**m** DIMENSIONS IN METRES  
 EXCEPT AS NOTED

**NOTES:**

1. BOULEVARD WIDTHS TO BE MAINTAINED AS PER ROAD CROSS-SECTION DETAILS THROUGHOUT THE CURVE.
2. 20m MINIMUM STRAIGHT R.O.W. BEYOND/BETWEEN CURVES.
3. FOR OTHER CURB RADII REFER TO DESIGN CRITERIA.
4. VALUES PROVIDED RELATE TO CROWN ROADWAY SECTIONS AND THE VALUES REFLECT NORMAL CROWN. VALUES MAY BE REDUCED IN CONSULTATION WITH THE CITY BY WAY OF APPLYING ROADWAY SUPER-ELEVATION OR REDUCING DESIGN SPEED UPON APPROVAL BY THE CITY.\*

4.		
3.		
2.		
1.	*REVISED MINIMUM RADII NOTES AND ADDED NOTE #4	11/24
	REVISIONS	DATE



CITY OF VAUGHAN ENGINEERING STANDARD

**HORIZONTAL CURVE**

NOT TO SCALE      DESIGNED: \_\_\_\_\_  
 REVISION:   1        DATE:   DEC. 2020  

STD. DWG.  
**R - 109**

NOTES

1. ALL ROADS TO INTERSECT AT 90°.
2. MAJOR AND MINOR LEGS OF THE INTERSECTION MAY REQUIRE 2.0m MEDIAN SUBJECT TO CITY REQUEST.
3. LANE MARKINGS TO BE TAPERED IN ACCORDANCE WITH O.T.M. BOOK 11.
4. LOCAL TO ARTERIAL INTERSECTIONS DISCOURAGED & WHERE NECESSARY THEIR DESIGN MUST BE APPROVED BY THE CITY AND REGION (WHERE APPLICABLE).
5. INCREASED CURB RADII CAN BE CONSIDERED WHERE JUSTIFIED BASED ON HIGH TRAFFIC AND/OR BUS VOLUMES EXPECTED.

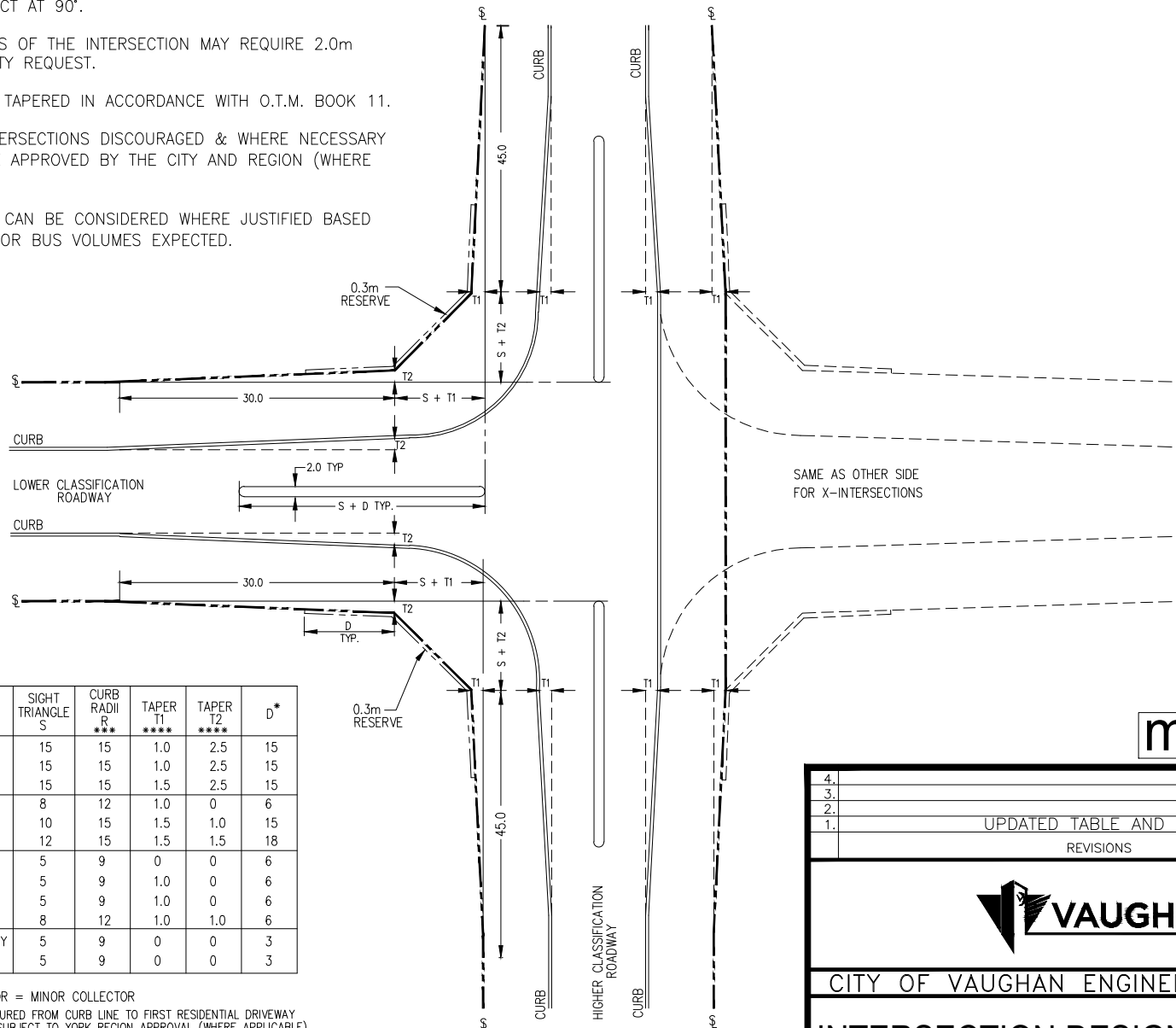

TABLE:

INTERSECTION OF:	SIGHT TRIANGLE S	CURB RADII R ***	TAPER T1 ****	TAPER T2 ****	D*
ARTERIAL AND LOCAL **	15	15	1.0	2.5	15
ARTERIAL AND MINOR **	15	15	1.0	2.5	15
ARTERIAL AND MAJOR **	15	15	1.5	2.5	15
MAJOR AND LOCAL	8	12	1.0	0	6
MAJOR AND MINOR	10	15	1.5	1.0	15
MAJOR AND MAJOR	12	15	1.5	1.5	18
MINOR AND LANEWAY	5	9	0	0	6
MINOR AND LOCAL	5	9	1.0	0	6
MINOR AND BUFFER	5	9	1.0	0	6
MINOR AND MINOR	8	12	1.0	1.0	6
LOCAL AND LOCAL/BUFFER/LANEWAY	5	9	0	0	3
BUFFER AND BUFFER/LANEWAY	5	9	0	0	3

MAJOR = MAJOR COLLECTOR; MINOR = MINOR COLLECTOR

\* SUBJECT TO MAXIMUM 25m MEASURED FROM CURB LINE TO FIRST RESIDENTIAL DRIVEWAY (NOT MULTI-UNIT APPARMENTS) SUBJECT TO YORK REGION APPROVAL (WHERE APPLICABLE).

\*\* UNLESS OTHERWISE REQUIRED BY YORK REGION

\*\*\* THE CITY WOULD WELCOME SMALLER CURB RADII TO BENEFIT PEDESTRIANS IN URBAN AREAS, INTENSIFICATION AREAS AND AREAS WITH HIGHER DENSITY. THE CITY'S TRANSPORTATION MASTER PLAN MAKES RECOMMENDATIONS FOR OPTIMUM CURB RADII (CITY OF VAUGHAN 2012, 6-21). PROPOSALS TO REDUCE CURB RADII SHALL BE SUPPORTED BY A TRANSPORTATION CONSULTANT.

\*\*\*\* THE PROVISION OF TAPER T1 AND T2 IS SUBJECT TO CITY DISCRETION/REQUIREMENT.

**m** DIMENSIONS IN METRES EXCEPT AS NOTED

4.		
3.		
2.		
1.	UPDATED TABLE AND NOTES	11/24
	REVISIONS	DATE



CITY OF VAUGHAN ENGINEERING STANDARD

INTERSECTION DESIGN GUIDELINES

NOT TO SCALE  
DESIGNED: \_\_\_\_\_  
REVISION: 1 DATE: AUG. 2021

STD. DWG.  
**R - 110**



# LOCATION PLAN

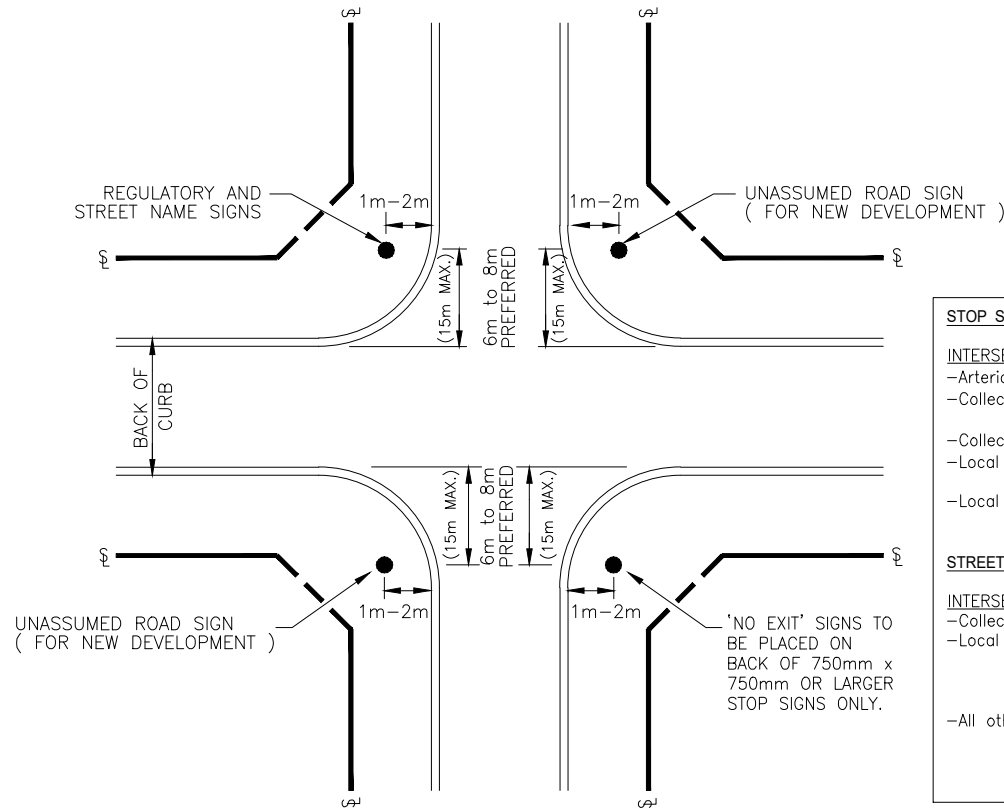

# INSTALLATION DETAIL

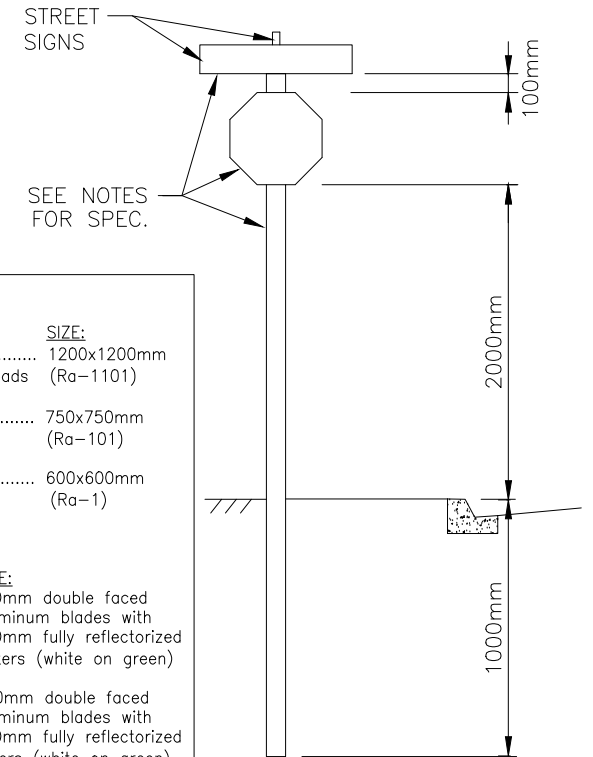

STOP SIGN SIZES	
<b>INTERSECTION:</b>	<b>SIZE:</b>
-Arterial to Arterial, Collector (14m), .....	1200x1200mm
-Collector (14m) to Collector (14m) roads (Ra-1101)	
-Collector (11.5m) to Collector (14m).....	750x750mm
-Local to Collector	(Ra-101)
-Local to Local roads .....	600x600mm
	(Ra-1)
STREET NAME SIGN SIZES	
<b>INTERSECTION:</b>	<b>SIZE:</b>
-Collector to Local .....	150mm double faced
-Local to Local roads	aluminum blades with
	100mm fully reflectorized
	letters (white on green)
-All other roads .....	200mm double faced
	aluminum blades with
	150mm fully reflectorized
	letters (white on green)

## NOTES

1. REGULATORY SIGN AS PER OHTA REG. 615/95 OR AMENDMENTS THEREOF.
2. ALL REGULATORY SIGNS MANUFACTURES USING HIGH INTENSITY DIAMOND GRADE (OR EQUIVALENT) RETROREFLECTIVE SHEETING STAMPED WITH DATE (MONTH/YEAR) ON SIGN FACE BY MANUFACTURER.
3. SIGN POSTS SHALL BE BREAKAWAY-TYPE IN ACCORDANCE WITH MTD 986.101, 986.105, 987.101, 987.105 AND OPSS 915.
4. REGULATORY AND STREET SIGNS MAY BE PLACED ON LIGHT STANDARDS, PROVIDED THEY ARE CLEARLY VISIBLE AND WITHIN SPECIFIED LOCATIONS.
5. SPECIAL CIRCUMSTANCES MAY WARRANT LARGER STOP SIGNS, OR SECOND STOP SIGN ON SAME APPROACH.

**m** DIMENSIONS IN METRES  
EXCEPT AS NOTED

4.		
3.		
2.		
1.		
REVISIONS		DATE



CITY OF VAUGHAN ENGINEERING STANDARD

## STREET SIGNS

NOT TO SCALE      DESIGNED: \_\_\_\_\_  
REVISION: \_\_\_\_\_      DATE: DEC. 2020

STD. DWG.  
**R - 111**

FILE: G:\Infrastructure Delivery\Infrastructure Programming\PMO\City Standards\Design Criteria\2020-21\City Standards Update\Folder\CoStandardDrawings\_CAD\_2021\R-112 - Breakaway Bollard Detail.dwg

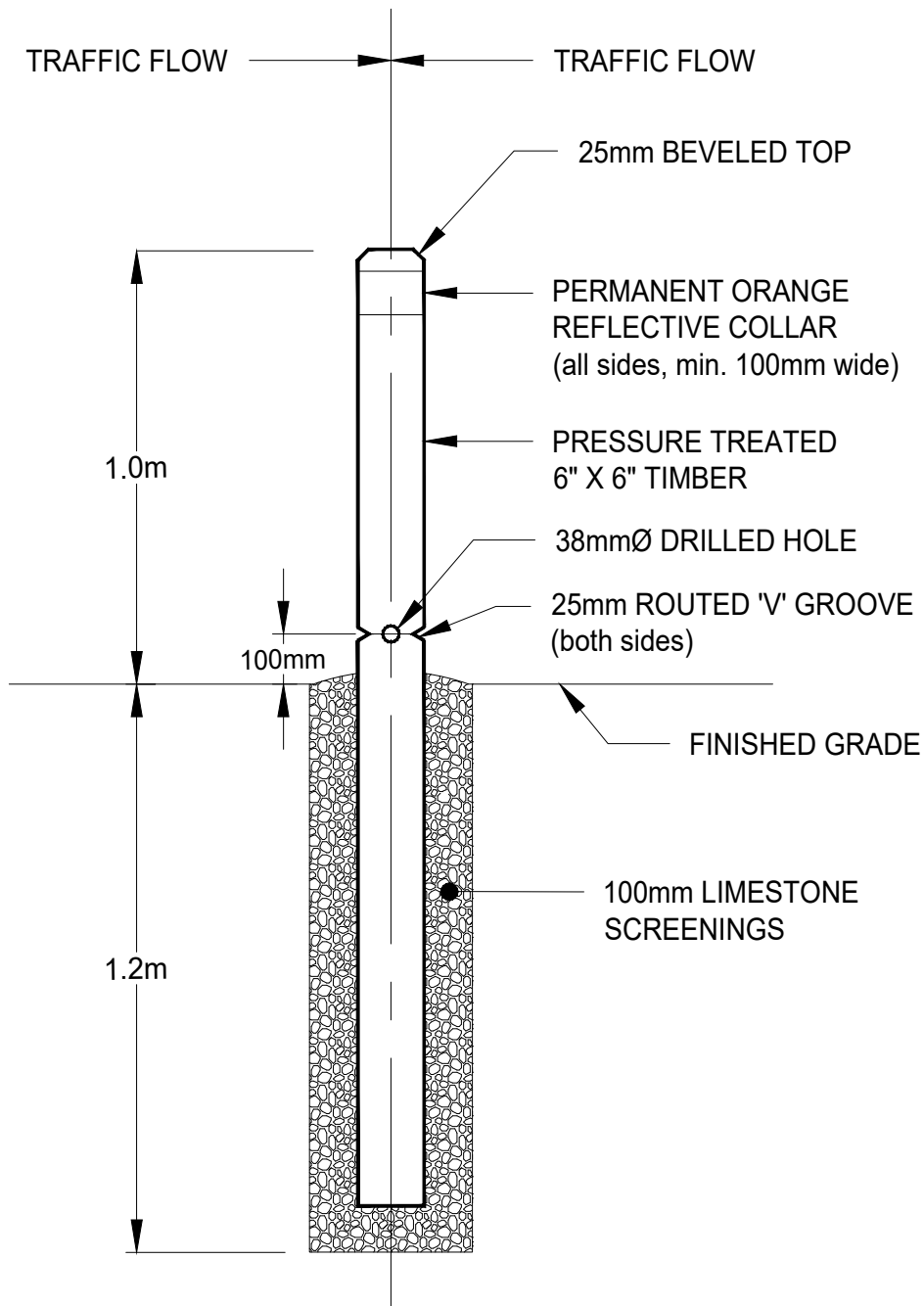

**NOTE:**

1. BOLLARDS MUST BE PLACED WITH 'V' GROOVES PERPENDICULAR TO TRAFFIC FLOW.
2. BOLLARD POSTS TO BE INSTALLED WITH MIN 2.0m CLEARANCE FROM ANY FIXED STRUCTURE/OBSTACLE

4.		
3.		
2.		
1.		
REVISIONS		DATE



CITY OF VAUGHAN ENGINEERING STANDARD

**BREAKAWAY BOLLARD DETAIL**

NOT TO SCALE      DESIGNED: \_\_\_\_\_

REVISION: \_\_\_\_\_      DATE: DEC. 2020

STD. DWG.

**R - 112**

**mm** DIMENSIONS IN MILLIMETRES  
EXCEPT AS NOTED

FILE: C:\Infrastructure\Delivery\Infrastructure Programming\PMO\City Standards\Design Criteria\2020-21\City Standards Update\Folders\City Standards Drawings\_CAD\_2021\R-113 - Dead End Barricade.dwg

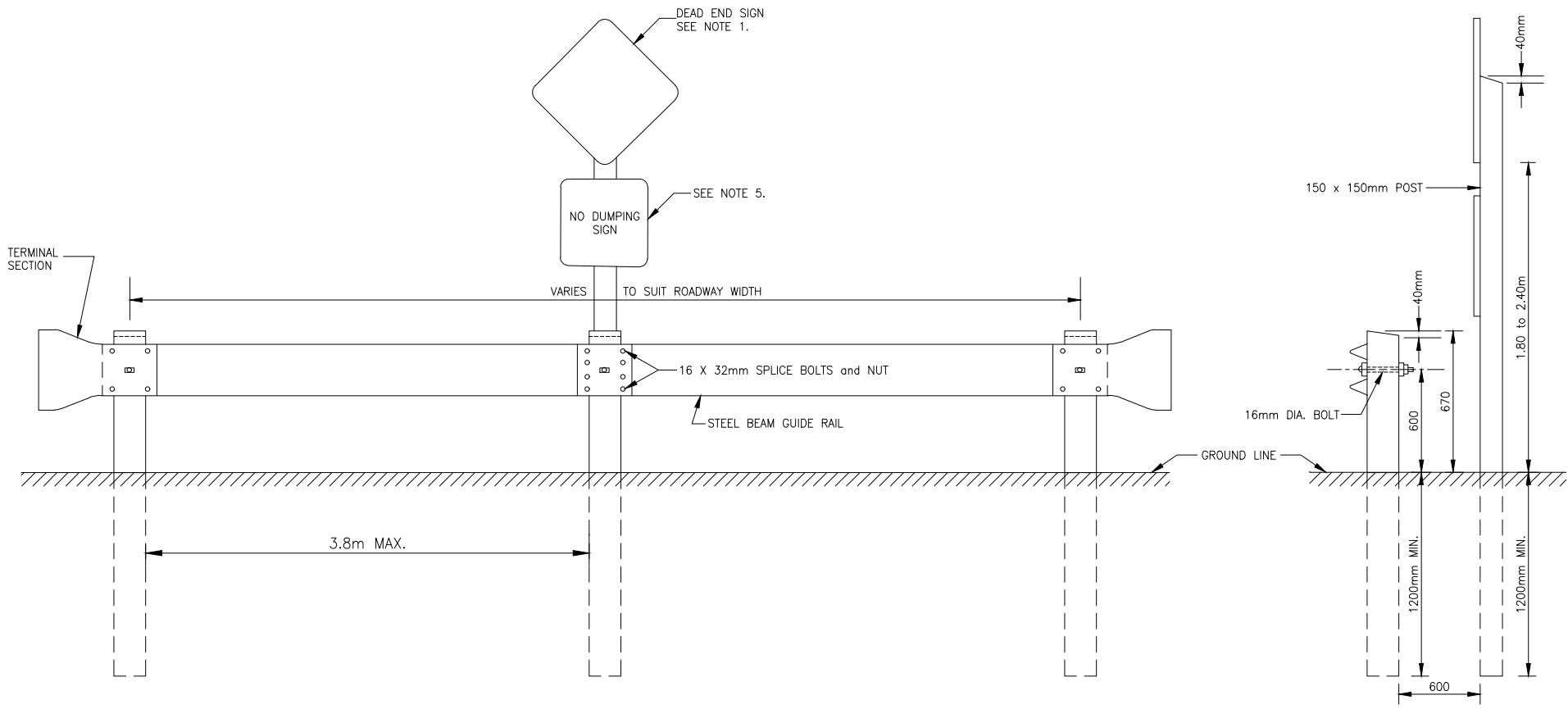

**ELEVATION**

**NOTES**

1. DEAD END SIGN AS SPECIFIED IN THE ONTARIO TRAFFIC MANUALS (OTM)
2. ALL METAL TO BE GALVANIZED.
3. DEAD END BARRICADES REQUIRED WHEN A ROAD ENDS WITHOUT A TURNING CIRCLE AND TO EXTEND 2.0m BEYOND CURB LINE.
4. ALL POSTS TO BE GALVANIZED STEEL.
5. NO DUMPING SIGN TO BE IN ACCORDANCE WITH THE CITY STANDARDS (TRANSPORTATION SERVICES, PARKS AND FORESTRY OPERATIONS)

**mm** DIMENSIONS IN MILLIMETRES EXCEPT AS NOTED

4.		
3.		
2.		
1.		
REVISIONS		DATE



CITY OF VAUGHAN ENGINEERING STANDARD

**DEAD END BARRICADE**

NOT TO SCALE      DESIGNED: \_\_\_\_\_  
 REVISION: \_\_\_\_\_      DATE: DEC. 2020

STD. DWG.  
**R - 113**

FILE: C:\Infrastructure\Delivery\Infrastructure Programming\PMO\City Standards\Design Criteria\2020-21\City Standards Update\Folder\Co\StandardDrawings\_CAD\_2021\R-114 - Construction Traffic Barricades.dwg

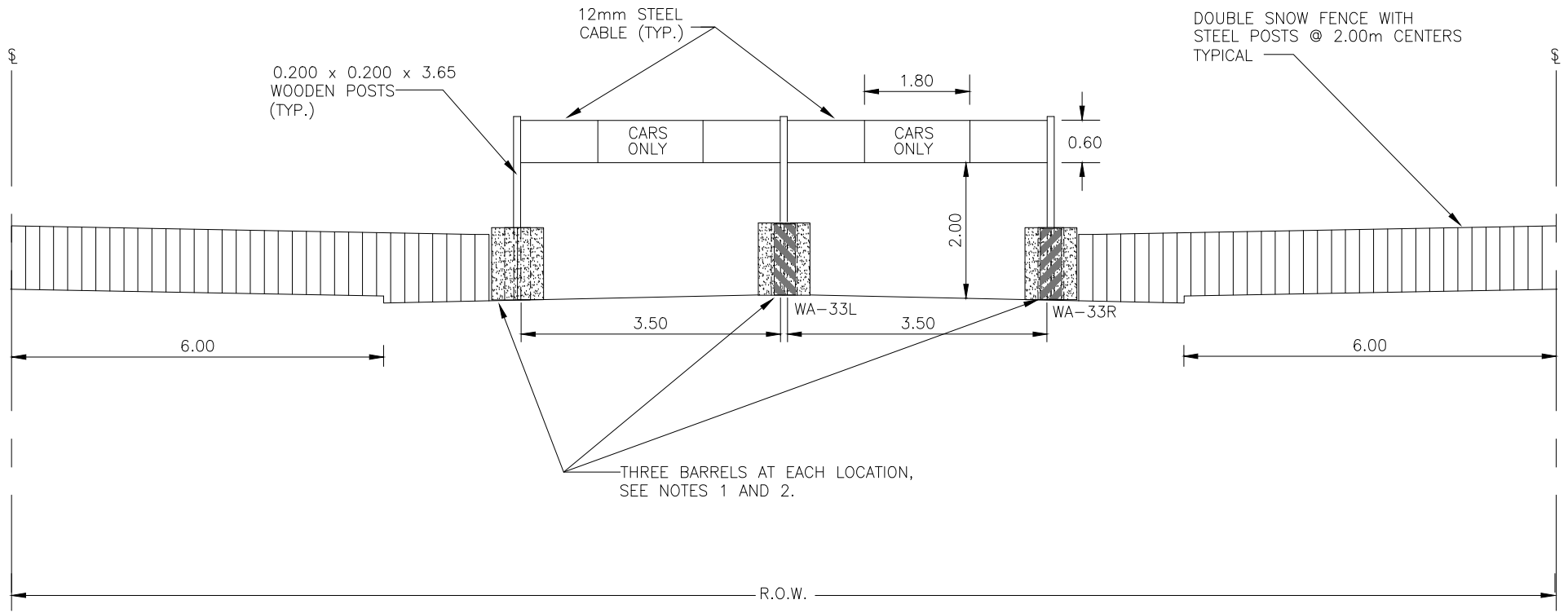

**NOTES**

1. TWO FRONT BARRELS TO BE FILLED WITH SAND; REAR BARREL TO BE FILLED WITH CONCRETE.
2. CONTRACTOR TO EMBED 200 x 200mm POSTS IN REAR BARREL.
3. MINIMUM LANE WIDTH TO BE 3.00m.
4. MINIMUM CLEARANCE FROM BOTTOM OF OVERHEAD SIGN TO ROAD TO BE 2.00m.
5. CABLE TO BE ATTACHED TO POSTS WITH BOLTS TO PERMIT EMERGENCY VEHICLES TO CUT THE BOLTS AND NOT THE CABLES TO GAIN ACCESS.
6. OVERHEAD SIGNS SHALL HAVE AN ORANGE BACKGROUND WITH A BLACK LEGEND MESSAGE AND SIGN BORDER.
7. ALL SIGNS SHALL BE REFLECTORIZED TO SHOW THE SAME COLOUR AND SHAPE BY DAY AS BY NIGHT.
8. SIGNAGE TO BE THE SAME FOR OPPOSING DIRECTION.
9. DELINEATORS TO BE INSTALLED ON BOTH OPENINGS, BOTH DIRECTIONS.

**m** DIMENSIONS IN METRES  
EXCEPT AS NOTED

4.		
3.		
2.		
1.		
REVISIONS		DATE



CITY OF VAUGHAN ENGINEERING STANDARD

**CONSTRUCTION TRAFFIC BARRICADES**

NOT TO SCALE      DESIGNED: \_\_\_\_\_  
 REVISION: \_\_\_\_\_      DATE: DEC. 2020

STD. DWG.  
**R - 114**

SPEED HUMP, RAISED CROSSWALK  
& RAISED INTERSECTION

600x600mm  
WARNING SIGN

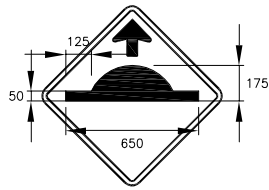

750x750mm  
WARNING SIGN

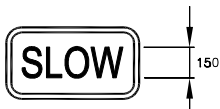
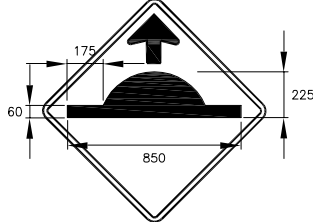

600x300mm TAB

INSTALL ON  
LOCAL ROADS



750x450mm TAB

INSTALL ON PRIMARY/FEEDER  
ROADS OR ABOVE

ROUNDABOUT

600x600mm  
WARNING SIGN



600x300mm TAB

INSTALL ON  
LOCAL ROADS

750x750mm  
WARNING SIGN



750x450mm TAB

INSTALL ON PRIMARY/FEEDER  
ROADS OR ABOVE

MEDIAN

750x750mm  
WA-23L LANE  
REDUCTION SIGN

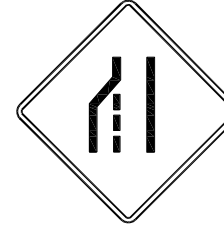

INSTALL IF MEDIAN RESULTS  
IN LANE REDUCTION

CURB EXTENSION  
& CHICANE

750x750mm  
WA-23R LANE  
REDUCTION SIGN

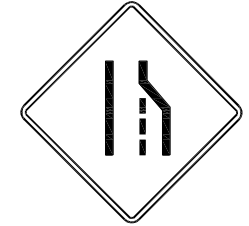

INSTALL IF CURB  
EXTENSION OR CHICANE  
RESULTS IN LANE REDUCTION

INSTALL IN BOTH DIRECTIONS PER THE FOLLOWING (EXCEPT AS NOTED):

1. 100m IN ADVANCE OF EACH MEASURE IF ON LOCAL ROAD, 150m IF ON PRIMARY/FEEDER ROAD OR ABOVE.
2. IN ADVANCE OF SERIES OF MEASURES IF THEY ARE LESS THAN 300m APART.
3. ON PROPERTY LINES WHEREVER POSSIBLE.
4. ON EXISTING LIGHT STANDARD OR UTILITY POLE IF WITHIN 30m OF LOCATION DETERMINED THROUGH PRECEDING STEPS.

TRAFFIC-CALMED  
NEIGHBOURHOOD

600x450mm  
WHITE ON GREEN SIGN



600x225mm  
WHITE ON GREEN TAB

INSTALL ON ALL STREETS  
ENTERING A TRAFFIC CALMED  
NEIGHBOURHOOD  
(MIN. 20m FROM ARTERIAL ROAD  
WHEREVER POSSIBLE)

NOTES:

1. ALL SIGNS MUST BE VISIBLE TO MOTORISTS FROM A DISTANCE OF 65m ON LOCAL ROADS, AND 85m ON PRIMARY/FEEDER ROADS WHEREVER POSSIBLE. TRIM OR RELOCATE OBSTRUCTING BOULEVARD TREES IF NECESSARY.
2. LETTERING AND SYMBOLS TO BE BLACK ON HIGH INTENSITY REFLECTIVE YELLOW BACKGROUND, EXCEPT WHERE NOTED.
3. MOUNT ON 3.7m U-CHANNEL GALVANIZED STEEL POSTS, OR EXISTING LIGHT STANDARDS OR UTILITY POLES IF APPROPRIATE.
4. MOUNT SO THAT BOTTOM EDGE OF WARNING SIGN IS BETWEEN 2.0 AND 2.5m HIGH AND ROADSIDE EDGE IS AT LEAST 0.3m BEHIND CURB.

4.		
3.		
2.		
1.		
REVISIONS		DATE



CITY OF VAUGHAN ENGINEERING STANDARD

**TRAFFIC CALMING ADVANCE  
WARNING SIGNS**

NOT TO SCALE

DESIGNED: \_\_\_\_\_ P.W.

STD. DWG.

REVISION: \_\_\_\_\_

DATE: MARCH 2004

**J - 1**

**mm** DIMENSIONS IN MILLIMETERS  
EXCEPT AS NOTED

Acad File: R:\ENCDRAFT\\$\$\$Design Std Drawings 2004\J-Traffic Calming\J-2.dwg

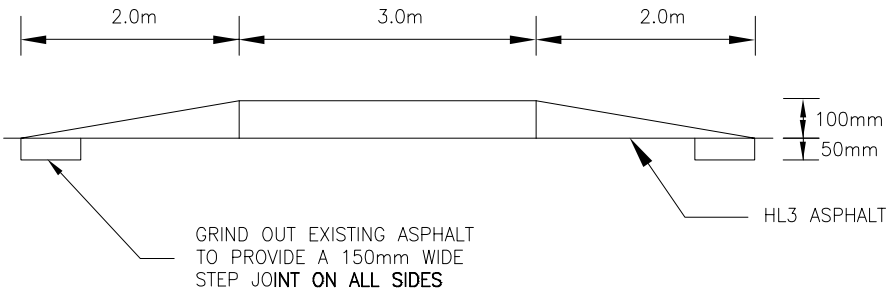
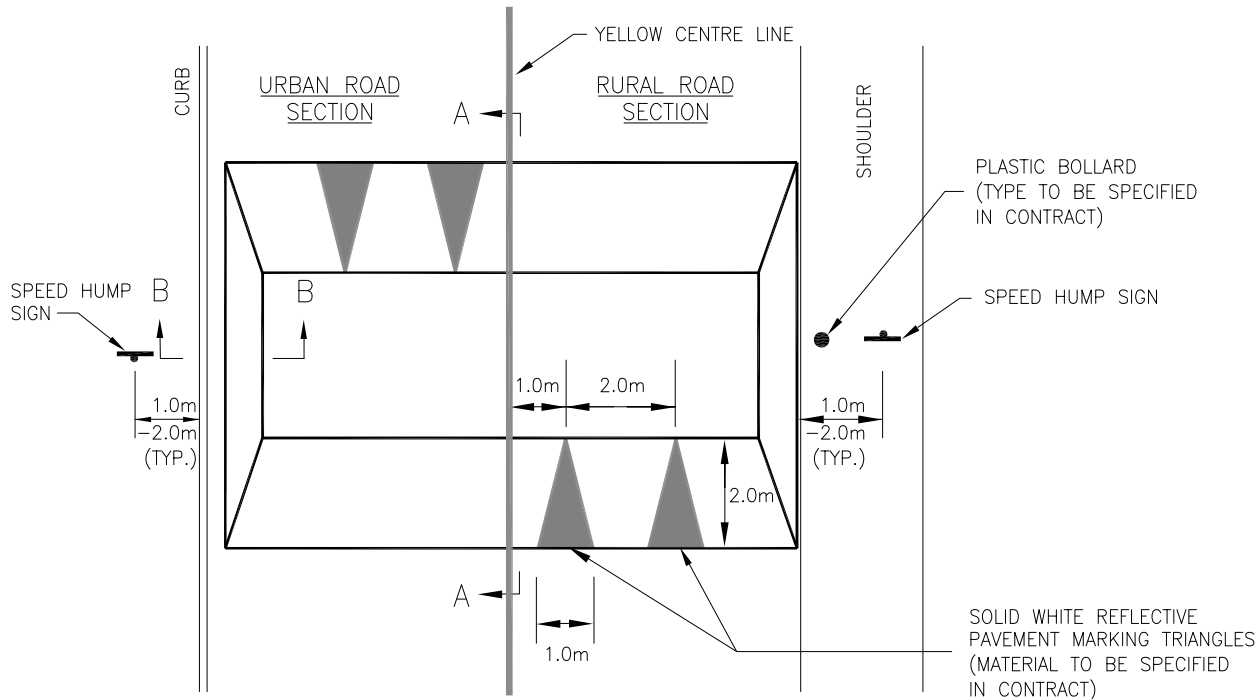

SECTION A-A

NOTES:

1. COLOURED IMPRESSED CONCRETE MAY BE SPECIFIED AS PER STD. DWG. J-3.
2. ALL SIGNS TO BE HIGH INTENSITY REFLECTIVE SHEETING ON GALVANIZED U-CHANNEL POSTS.
3. ADD THIRD PAVEMENT MARKING TRIANGLE ON EACH SIDE OF SPEED HUMP IF ON COLLECTOR ROAD.
4. INSTALL ADVANCE WARNING SIGNS IN ACCORDANCE WITH STD. DWG. J-1.

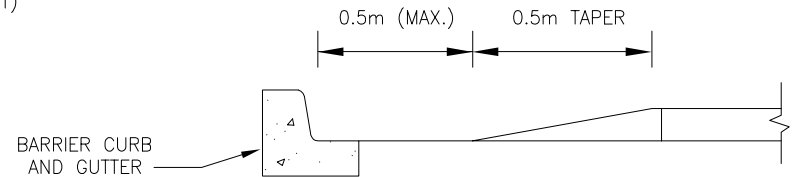
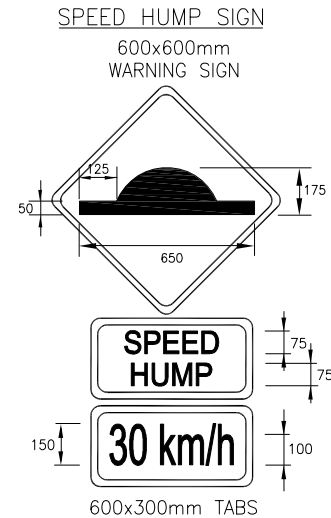

SECTION B-B  
URBAN ROAD SECTION

4.		
3.		
2.		
1.		
REVISIONS		DATE



CITY OF VAUGHAN ENGINEERING STANDARD

**SPEED HUMP**

NOT TO SCALE

DESIGNED: \_\_\_\_\_ P.W. \_\_\_\_\_

STD. DWG.

REVISION: \_\_\_\_\_

DATE: MARCH 2004

**J - 2**

**mm** DIMENSIONS IN MILLIMETERS  
EXCEPT AS NOTED

Acad File: R:\ENGDRAFT\\$\$\$Design Std Drawings 2004\J\_Traffic Calming\J-3.cdw

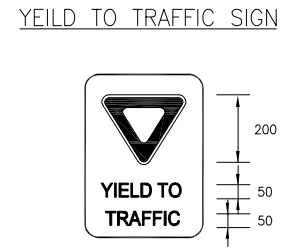
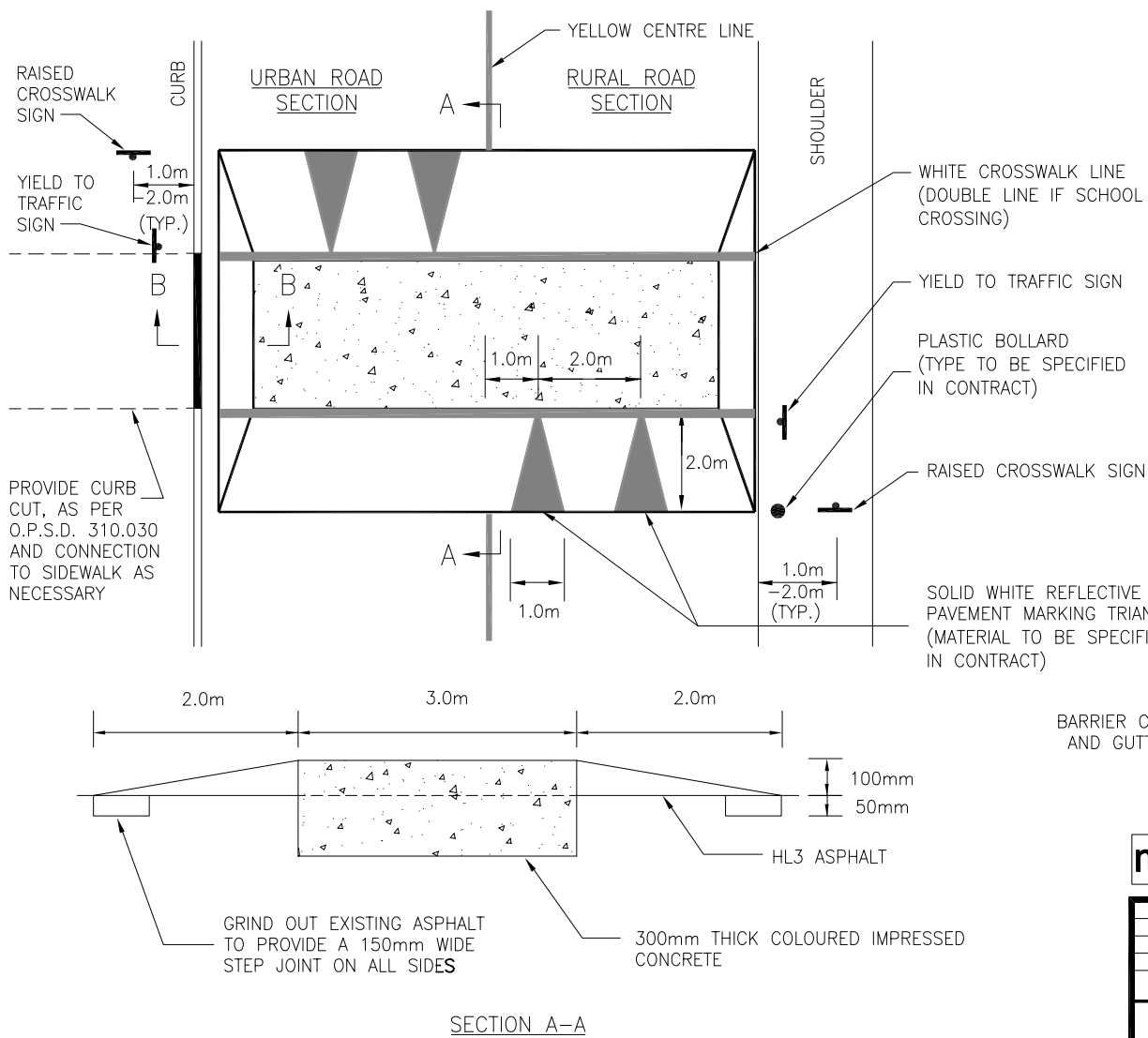

300x450mm SIGN  
(RED SYMBOL, BLACK LETTERS ON WHITE)

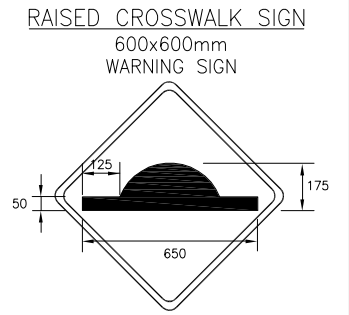

600x300mm TABS

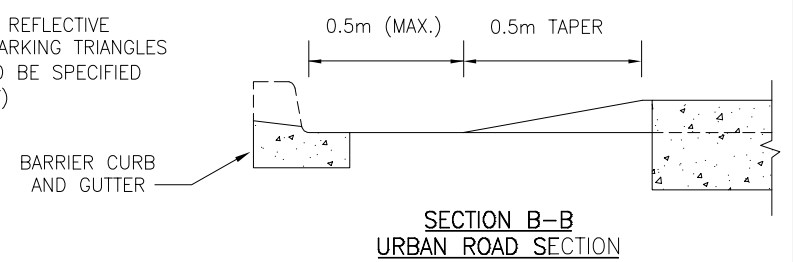

**mm** DIMENSIONS IN MILLIMETERS  
EXCEPT AS NOTED

4.		
3.		
2.		
1.		
REVISIONS		DATE

**NOTES:**

1. COLOUR AND PATTERN OF IMPRESSED CONCRETE TO BE CONFIRMED WITH CITY ENGINEERING DEPARTMENT AND SPECIFIED IN CONTRACT.
2. ALL SIGNS TO BE HIGH INTENSITY REFLECTIVE SHEETING ON GALVANIZED U-CHANNEL POSTS.
3. ADD THIRD PAVEMENT MARKING TRIANGLE ON EACH SIDE OF RAISED CROSSWALK IF ON COLLECTOR ROAD.
4. PARKING RESTRICTIONS MAY BE REQUIRED TO ENSURE PEDESTRIAN VISIBILITY.
5. INSTALL ADVANCE WARNING SIGNS IN ACCORDANCE WITH STD. DWG. J-1.



CITY OF VAUGHAN ENGINEERING STANDARD

**RAISED CROSSWALK**

NOT TO SCALE      DESIGNED: \_\_\_ P.W. \_\_\_  
REVISION: \_\_\_\_\_      DATE: MARCH 2004

STD. DWG.  
**J - 3**

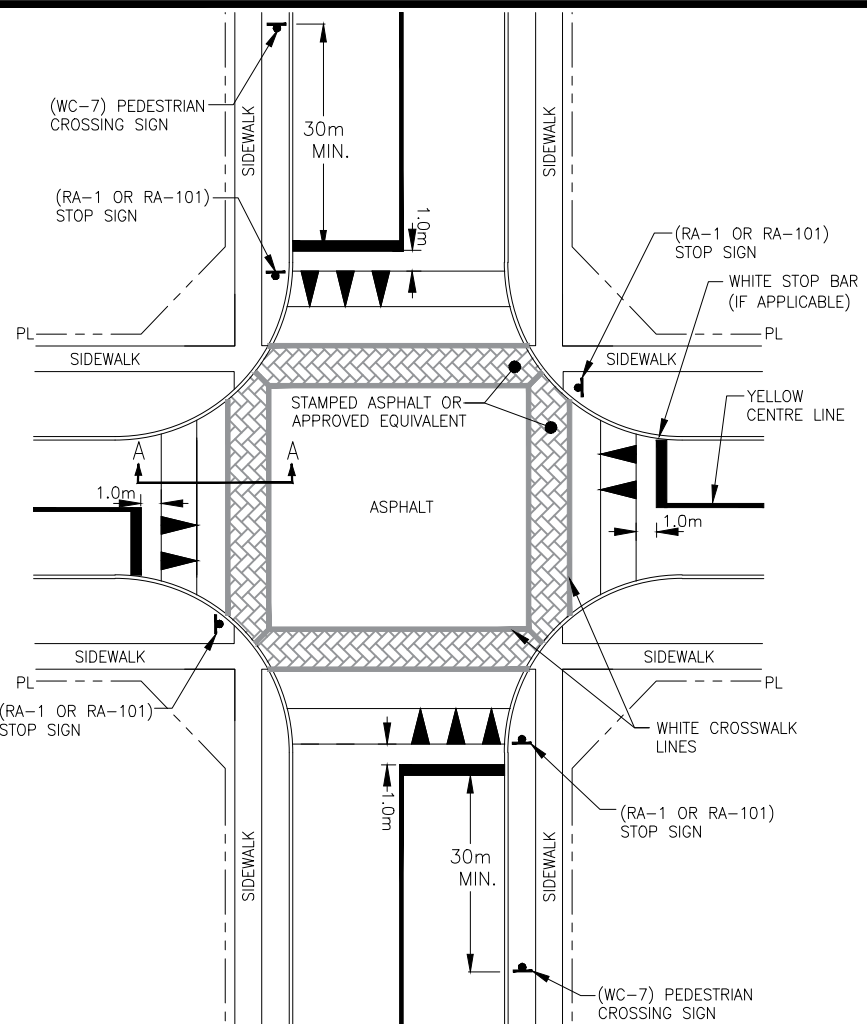

**RAISED INTERSECTION SIGN**  
600x600mm  
WARNING SIGN

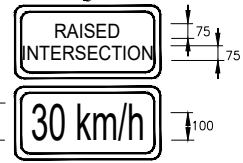
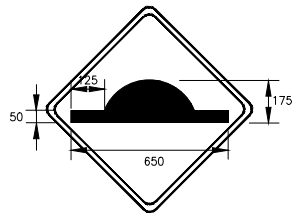

INSTALL AT ALL APPROACHES  
NOT UNDER STOP CONTROL

**PEDESTRIAN CROSSING SIGN (WC-7)**  
600x600mm  
WARNING SIGN

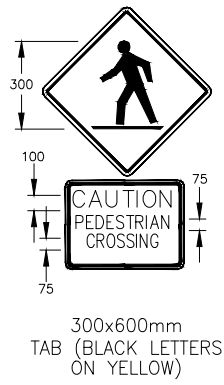

**PAVEMENT MARKING DETAIL**

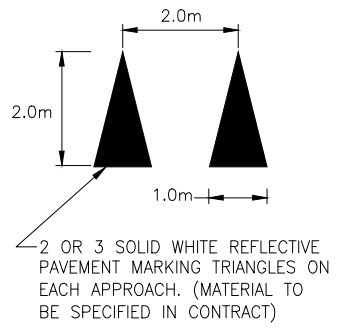

2 OR 3 SOLID WHITE REFLECTIVE  
PAVEMENT MARKING TRIANGLES ON  
EACH APPROACH. (MATERIAL TO  
BE SPECIFIED IN CONTRACT)

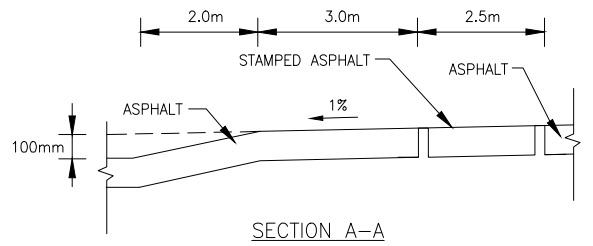

**NOTES:**

1. MAINTAIN ROAD GRADES THROUGH INTERSECTION.
2. ALL SIGNS TO BE HIGH INTENSITY DIAMOND GRADE (OR EQUIVALENT) RETRO-REFLECTIVE SHEETING ON GALVANIZED U-CHANNEL POSTS.
3. ADD THIRD PAVEMENT MARKING TRIANGLE ON EACH SIDE OF RAISED INTERSECTION IF ON COLLECTOR ROAD.
4. INSTALL ADVANCE WARNING SIGNS IN ACCORDANCE WITH STD. DWG. R-115.
5. ALL SIGN POSTS SHALL BE BREAKAWAY-TYPE IN ACCORDANCE WITH RELEVANT MTOD STANDARDS AND SPECIFICATIONS.
6. SHOULD THE INTERSECTION BE LATER APPROVED FOR AN ALL-WAY STOP CONTROL, THE RAISED INTERSECTION SIGN SHALL BE REMOVED.

4.		
3.		
2.		
1.	REVISED/UPDATED STANDARD	11/24
	REVISIONS	DATE



CITY OF VAUGHAN ENGINEERING STANDARD

**RAISED INTERSECTION**

NOT TO SCALE  
DESIGNED: \_\_\_\_\_  
REVISION: 1  
DATE: 2016

STD. DWG.  
**R - 118**



Acad File: R:\ENGDRAFT\Design Std Drawings 2004\J\_Traffic Calming\J-5.dwg

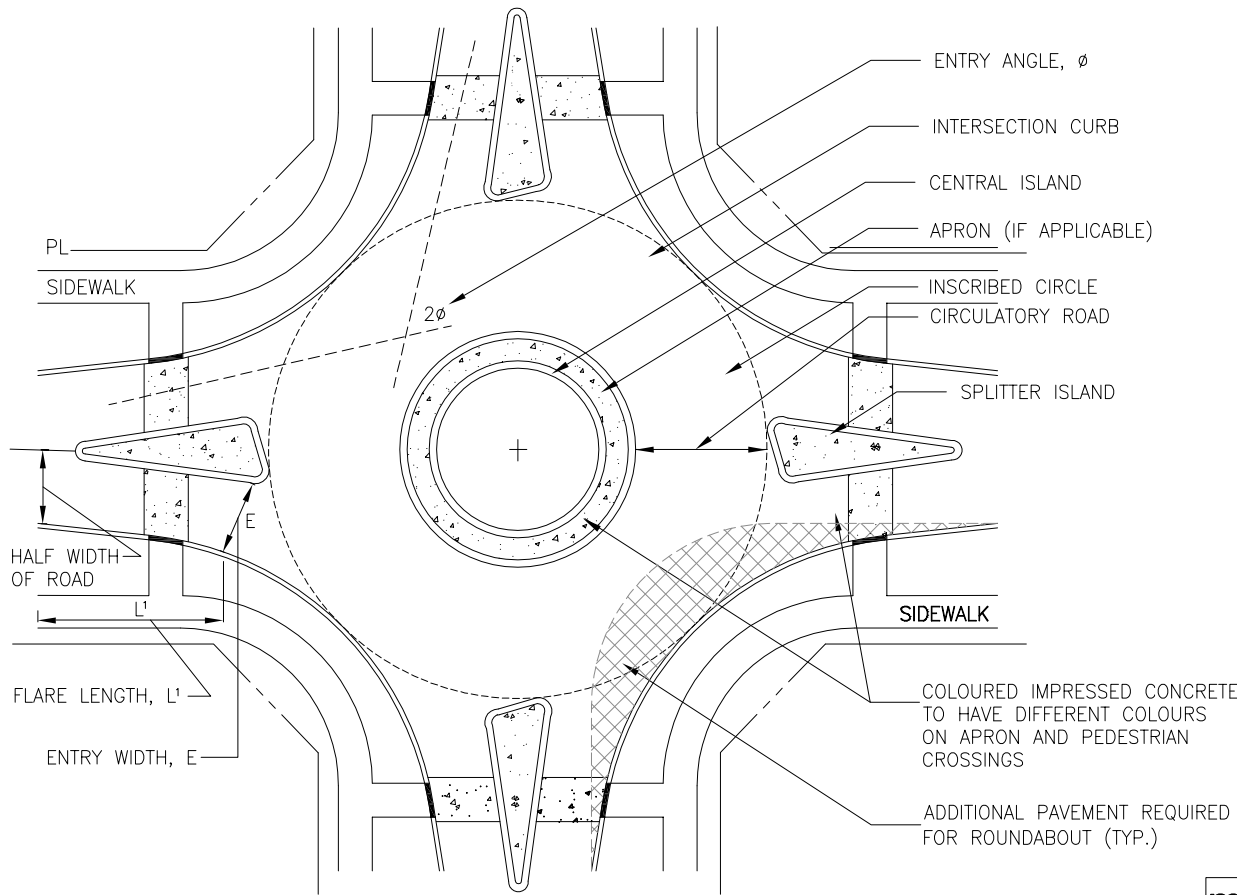

SPLITTER ISLANDS

LOCAL ROADS

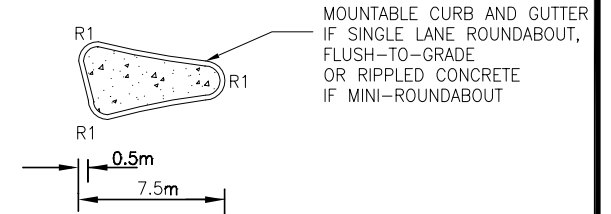

PRIMARY ROADS

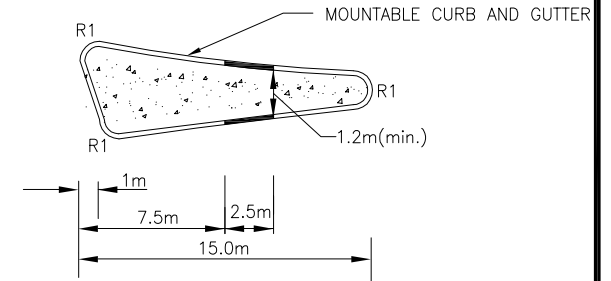

**mm** DIMENSIONS IN MILLIMETERS EXCEPT AS NOTED

4.		
3.		
2.		
1.		
REVISIONS		DATE



CITY OF VAUGHAN ENGINEERING STANDARD

**ROUNDABOUT LAYOUT**

NOT TO SCALE      DESIGNED: \_\_\_\_\_ P.W.

REVISION: \_\_\_\_\_      DATE: MARCH 2004

STD. DWG.

**J - 5**

NOTES:

- DESIGN AS PER F.H.W.A. GUIDELINES (ROUNDABOUTS: AN INFORMATIONAL GUIDE) AND GOOD ENGINEERING PRINCIPLES. CHECK HEAVY VEHICLE TURNING PATHS, FASTEST PATH SPEEDS AND SIGHTLINES.
- SKewed INTERSECTIONS AND INTERSECTIONS WITH COLLECTOR ROADS REQUIRE SITE-SPECIFIC DESIGNS.

ROUNDABOUT TYPE	SINGLE-LANE	MINI
INTERSECTION CURB RADIUS	11 - 31m	8 - 14m
INSCRIBED CIRCLE RADIUS	15 - 20m	7 - 12m
CENTRAL ISLAND RADIUS	8 - 10m	3 - 6m
APRON WIDTH	UP TO 3m	N/A
CIRCULATING ROAD WIDTH	6 - 7m	4 - 6m
ENTRY ANGLE, φ	20° - 60°	20° - 60°
ENTRY WIDTH, E	4.5 - 5.5m	4.5m
FLARE LENGTH, L'	5 - 20m	5 - 10m

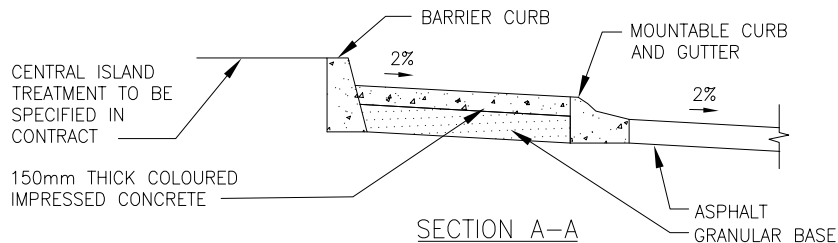
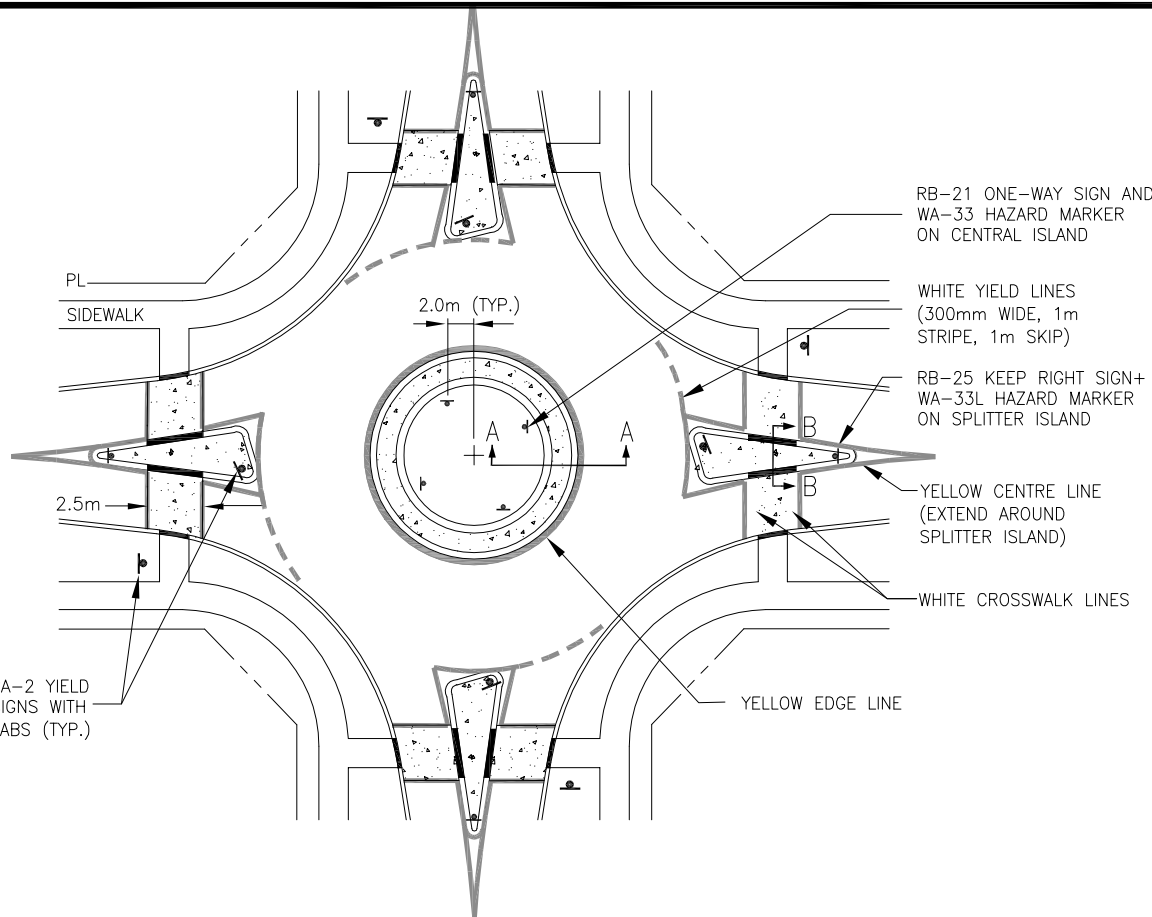

**NOTES:**

1. ALL APPROACHES TO BE UNDER YIELD CONTROL.
2. ALL SIGNS TO BE HIGH INTENSITY REFLECTIVE SHEETING ON GALVANIZED U-CHANNEL POSTS.
3. COLOUR AND PATTERN OF IMPRESSED CONCRETE TO BE CONFIRMED WITH CITY ENGINEERING DEPARTMENT AND SPECIFIED IN CONTRACT.
4. INSTALL ADVANCE WARNING SIGNS IN ACCORDANCE WITH STD. DWG. J-1.

**mm** DIMENSIONS IN MILLIMETERS  
EXCEPT AS NOTED

APPROACH SIGNAGE

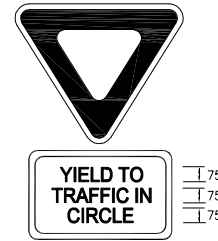

RA-2 YIELD SIGN AND 600x450mm TAB (BLACK LETTERS ON WHITE) INSTALL ON ALL APPROACHES

CENTRAL ISLAND SIGNAGE

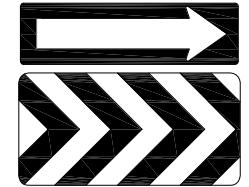

RB-21 ONE-WAY SIGN AND WA-33 HAZARD MARKER INSTALL FOR EACH DIRECTION

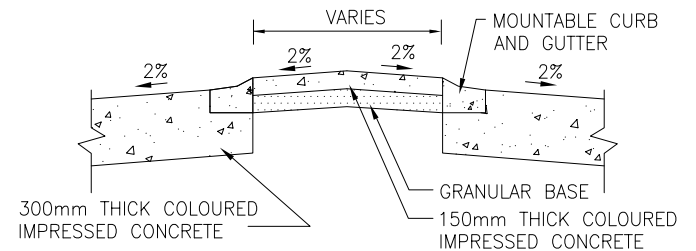

SECTION B-B

4.		
3.		
2.		
1.		
REVISIONS		DATE



CITY OF VAUGHAN ENGINEERING STANDARD

**SINGLE-LANE ROUNDABOUT**

NOT TO SCALE      DESIGNED: \_\_\_\_\_ P.W.  
REVISION: \_\_\_\_\_      DATE: MARCH 2004

STD. DWG.

**J - 6**

Acad File: R:\ENGDRAFT\Design Std Drawings 2004\Traffic Calming\J-7.dwg

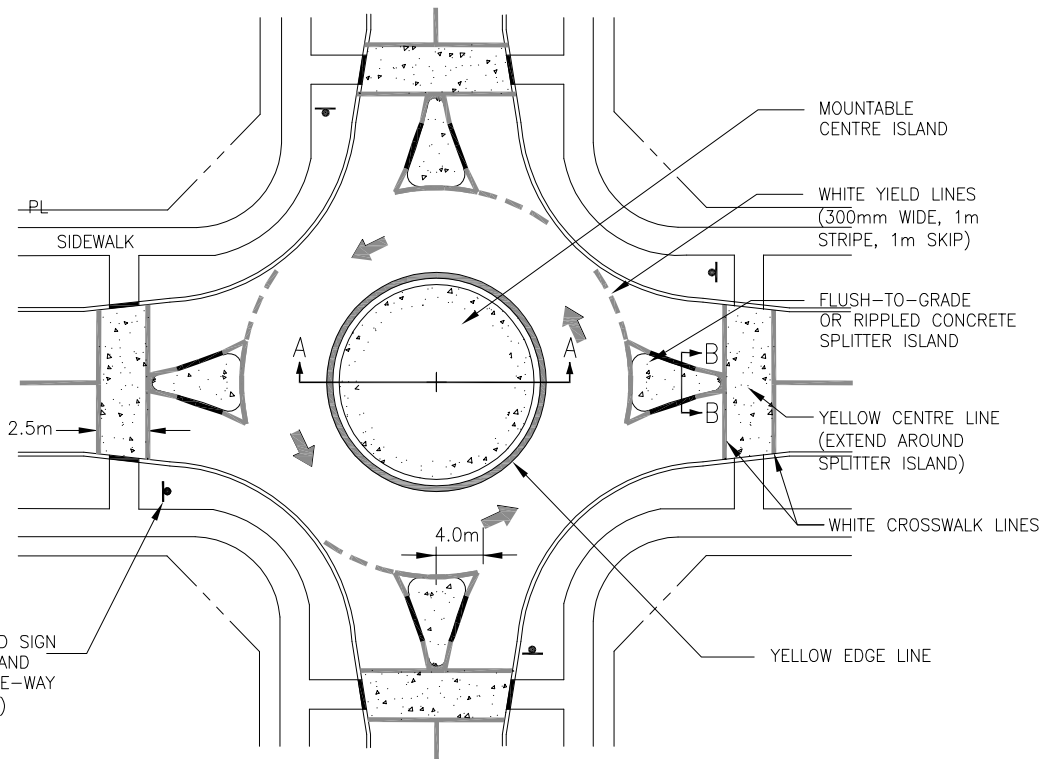

RA-2 YIELD SIGN WITH TAB AND RB-21 ONE-WAY SIGN (TYP.)

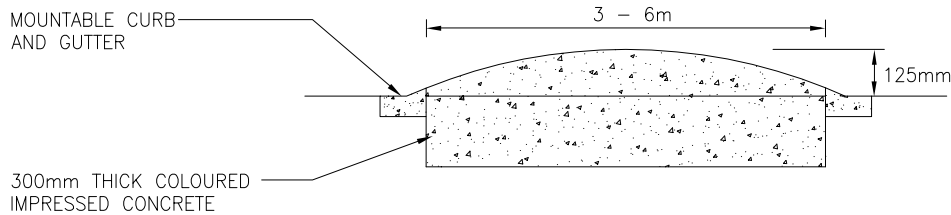

SECTION A-A

NOTES:

1. ALL APPROACHES TO BE UNDER YIELD CONTROL.
2. ALL SIGNS TO BE HIGH INTENSITY REFLECTIVE SHEETING ON GALVANIZED U-CHANNEL POSTS.
3. COLOUR AND PATTERN OF IMPRESSED CONCRETE TO BE CONFIRMED WITH CITY ENGINEERING DEPARTMENT AND SPECIFIED IN CONTRACT.
4. INSTALL ADVANCE WARNING SIGNS IN ACCORDANCE WITH STD. DWG. J-1.

**mm** DIMENSIONS IN MILLIMETERS  
EXCEPT AS NOTED

PAVEMENT MARKING DETAIL

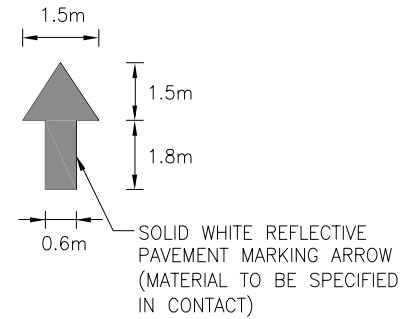

APPROACH SIGNAGE

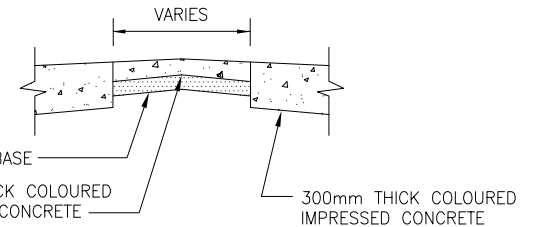
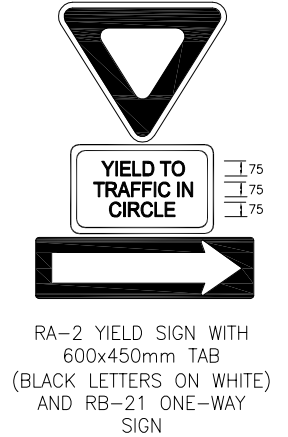

SECTION B-B

4.		
3.		
2.		
1.		
REVISIONS		DATE

**Vaughan**  
*The City Above Toronto*

**ENGINEERING**  
**DEPARTMENT**

CITY OF VAUGHAN ENGINEERING STANDARD

**MINI-ROUNDBABOUT**

NOT TO SCALE      DESIGNED: \_\_\_\_\_ P.W.  
REVISION: \_\_\_\_\_      DATE: MARCH 2004

STD. DWG.  
**J-7**

Acad File: R:\ENGORAF\\$\$\$Design Std Drawings 2004\Traffic Calming\J-8.dwg

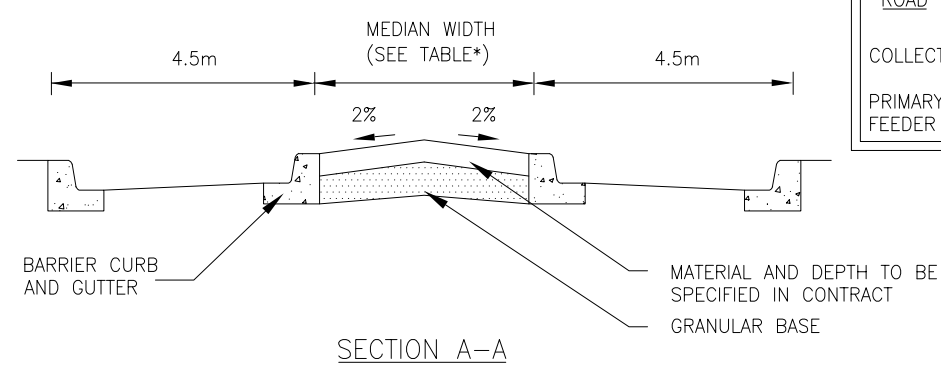
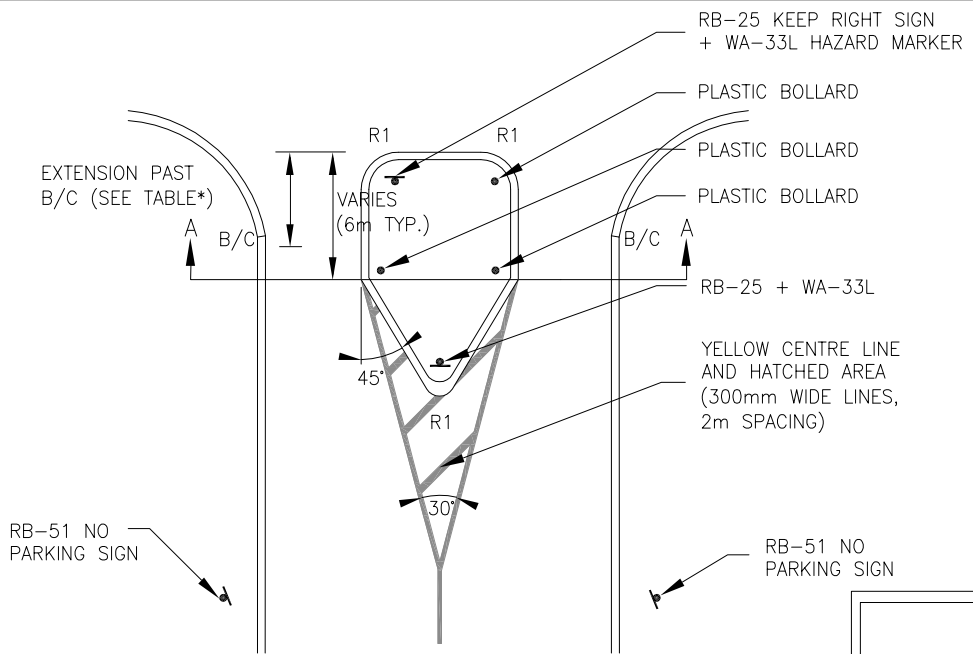

TABLE*		
ROAD	MEDIAN WIDTH	EXTENSION PAST B/C
COLLECTOR	5.0m	4.0m
PRIMARY/FEEDER	2.5m	5.0m

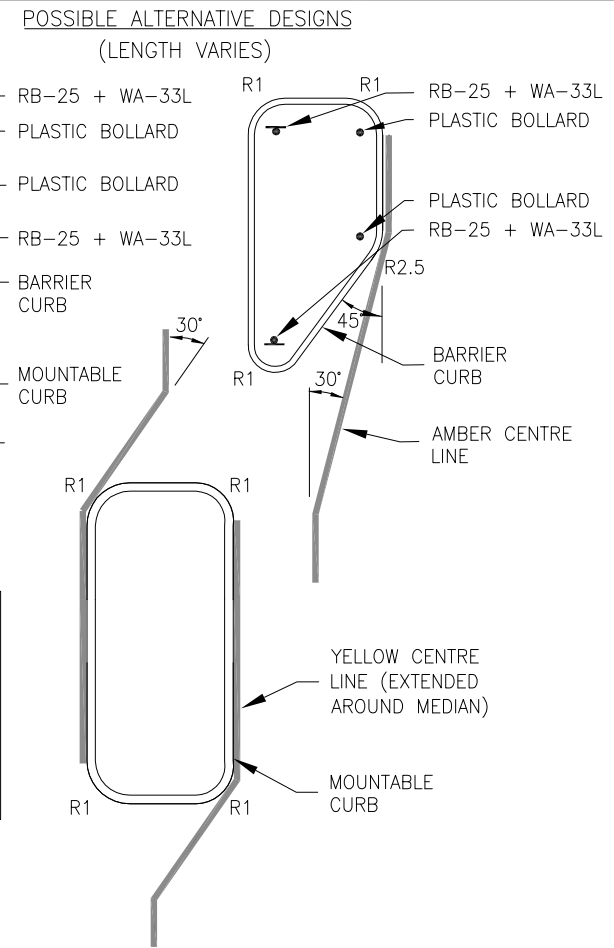

- NOTES:
1. POST NO PARKING SIGNS 15m EITHER SIDE OF ALL MEDIAN TYPES (BOTH SIDES).
  2. ALL SIGNS TO BE HIGH INTENSITY REFLECTIVE SHEETING ON GALVANIZED U-CHANNEL POSTS.
  3. PLASTIC BOLLARD TYPE TO BE SPECIFIED IN CONTRACT.
  4. INSTALL ADVANCE WARNING SIGNS IN ACCORDANCE WITH STD. DWG. J-1.

**mm** DIMENSIONS IN MILLIMETERS EXCEPT AS NOTED

4.		
3.		
2.		
1.		
REVISIONS		DATE

**Vaughan**  
The City Above Toronto

**ENGINEERING**  
DEPARTMENT

CITY OF VAUGHAN ENGINEERING STANDARD

## TRAFFIC CALMING MEDIANS

NOT TO SCALE	DESIGNED: _____ P.W.	STD. DWG.
REVISION: _____	DATE: MARCH 2004	<b>J - 8</b>

Acad File: R:\ENGDRAW\\$\$\$Design Std Drawings 2004\J\_Traffic Calming\J-9.dwg

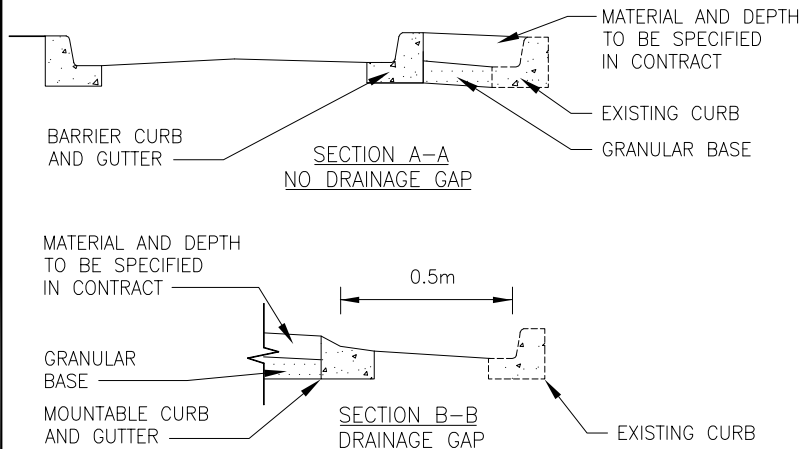
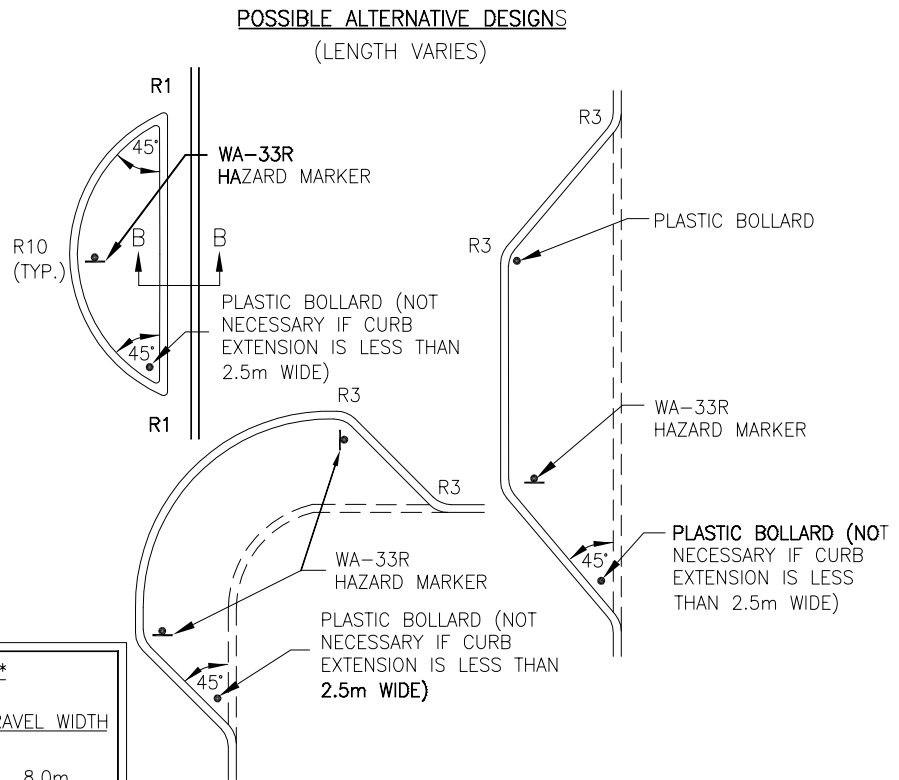
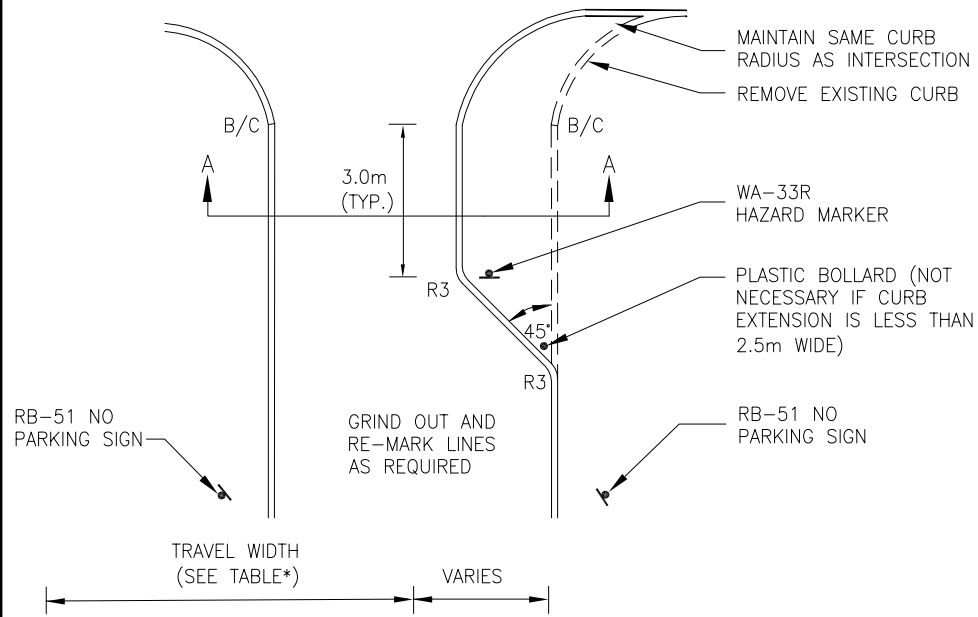

TABLE*	
ROAD	TRAVEL WIDTH
COLLECTOR	8.0m
PRIMARY/FEEDER	7.0m
LOCAL	6.0m

- NOTES:
1. POST NO PARKING SIGNS 15m EITHER SIDE OF ALL CURB EXTENSION TYPES (BOTH SIDES).
  2. ALL SIGNS TO BE HIGH INTENSITY REFLECTIVE SHEETING ON GALVANIZED U-CHANNEL POSTS.
  3. PLASTIC BOLLARD TYPE TO BE SPECIFIED IN CONTRACT.
  4. INSTALL ADVANCE WARNING SIGNS IN ACCORDANCE WITH STD. DWG. J-1.

**mm** DIMENSIONS IN MILLIMETERS  
EXCEPT AS NOTED

4.		
3.		
2.		
1.		
REVISIONS		DATE

--	--

**CITY OF VAUGHAN ENGINEERING STANDARD**  
**CURB EXTENSIONS and ROAD NARROWINGS**

NOT TO SCALE	DESIGNED: ___ P.W.	STD. DWG.
REVISION: _____	DATE: MARCH 2004	<b>J - 9</b>

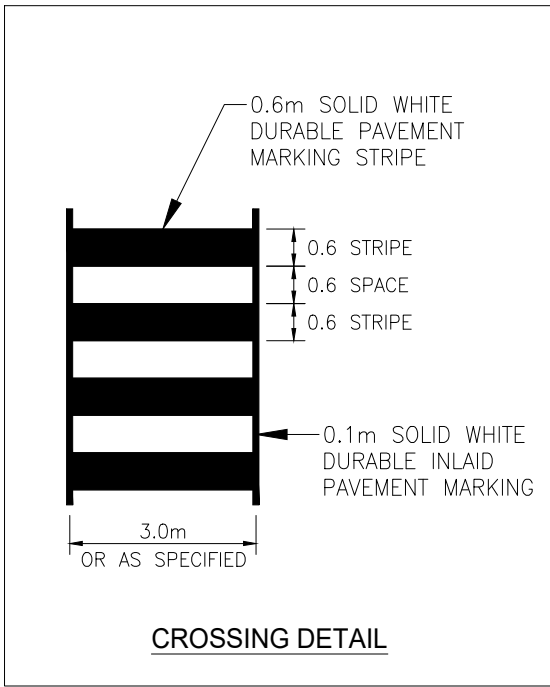
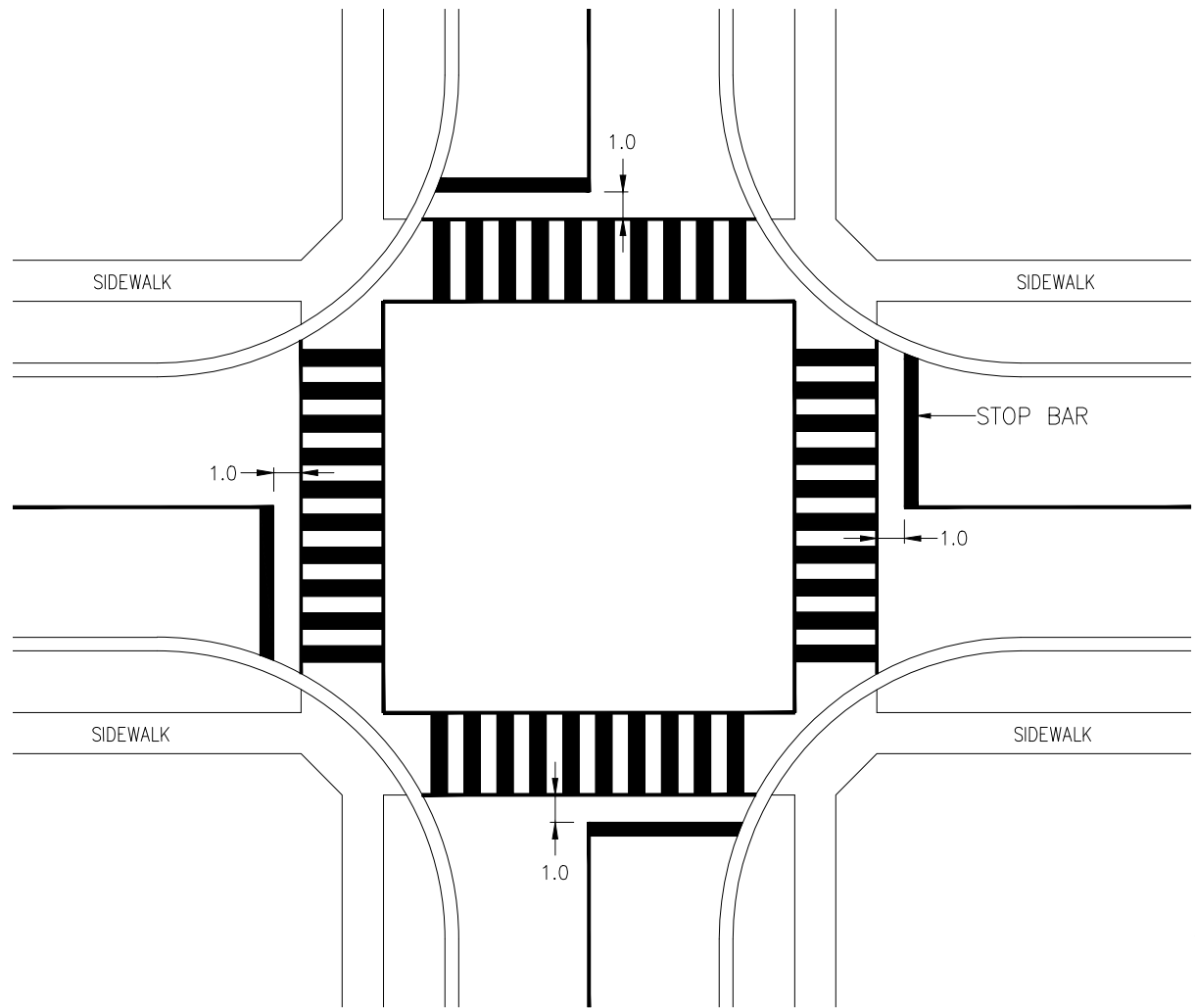

CROSSING DETAIL

**m** DIMENSIONS IN METRES  
EXCEPT AS NOTED

NOTES

1. ALL PAVEMENT MARKINGS SHALL BE DURABLE INLAID AS PER CONTRACT SPECIFICATIONS, UNLESS DIRECTED OTHERWISE.
2. TO PREVENT SLIPPAGE, THE FIRST STEP FROM THE CURB SHOULD NOT LAND ON A PAINTED BAR.
3. AT SKEW ANGLE CROSSWALKS, LADDER CROSSWALK MARKINGS ARE TO BE INSTALLED PARALLEL TO THE TRAFFIC FLOW (ie. ANGLED FOR THE PEDESTRIAN)
4. THIS DETAIL IS TO BE USED AS A GUIDE ONLY AND WILL REQUIRE ADJUSTMENTS TO SUIT FIELD CONDITIONS.

4.		
3.		
2.		
1.		
REVISIONS		DATE



CITY OF VAUGHAN ENGINEERING STANDARD

**LADDER PAVEMENT MARKING DETAIL  
AT SIGNALIZED INTERSECTIONS**

NOT TO SCALE      DESIGNED: \_\_\_\_\_  
REVISION: \_\_\_\_\_      DATE: DEC. 2020

STD. DWG.  
**R - 124**

FILE: C:\Infrastructure Delivery\Infrastructure Programming\PMO\City Standards\Design Criteria\2020-21\City Standards Update\Folders\CoS\StandardDrawings\_CAD\_2021\R-125 - Catchbasin\_Curb\_Detail.dwg

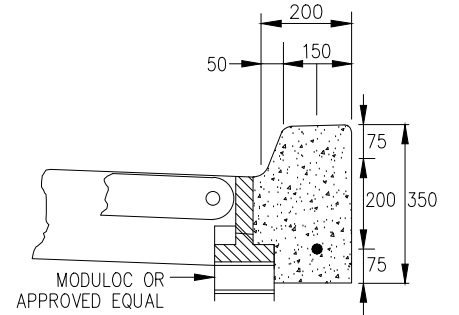
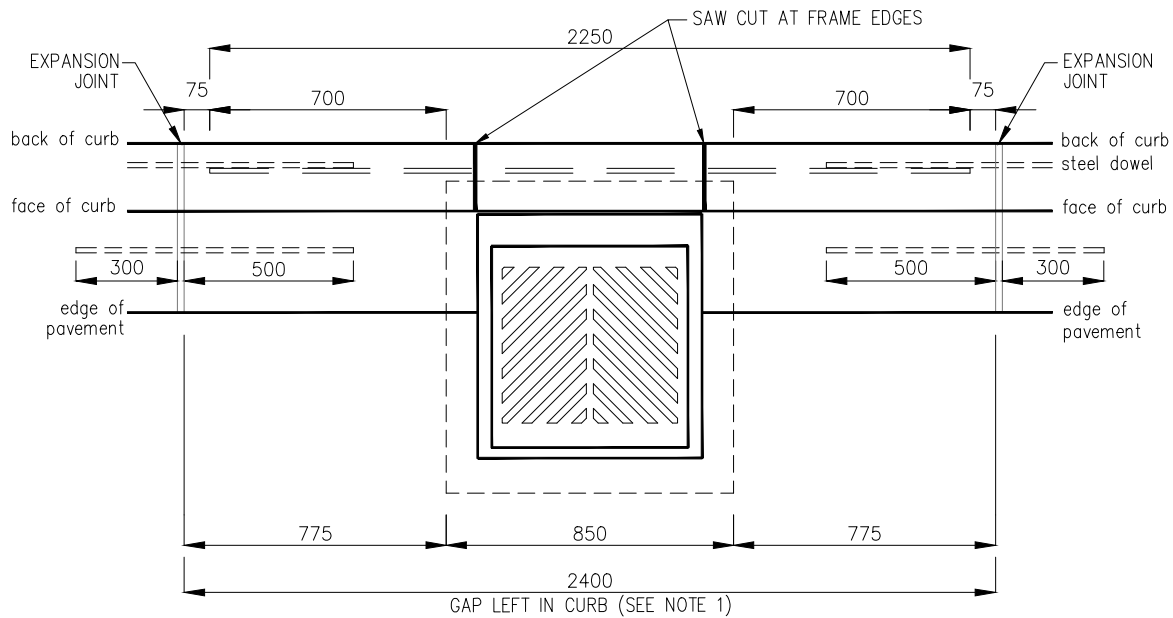
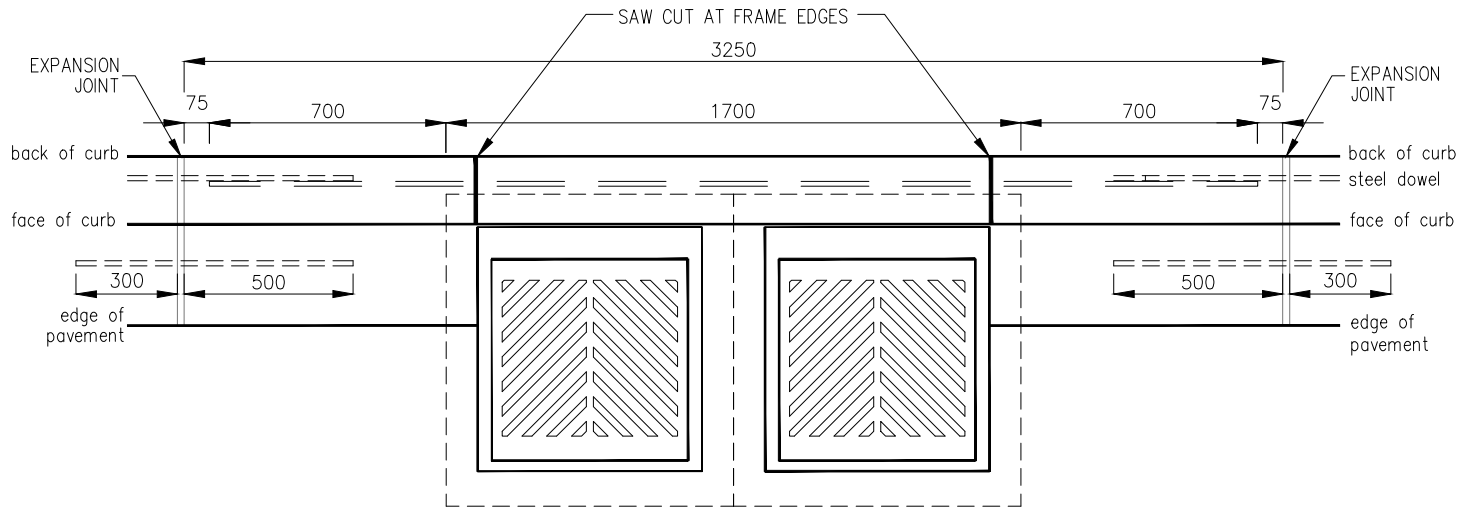

**NOTES:**

1. CATCHBASINS INITIALLY SET TO BASE OR CURB COURSE ASPHALT (WHICH EVER IS LOWER) WITH TEMPORARY ASPHALT CURB AND GUTTER BETWEEN EXPANSION JOINTS.
2. CATCHBASINS RAISED TO FINAL GUTTER LEVEL WITH MODULOC OR EQUAL, AND FULL CONCRETE CURB POURED PRIOR TO FINAL ASPHALT COURSE.
3. IN INDUSTRIAL/COMMERCIAL SUBDIVISIONS CB'S TO BE INSTALLED IN THE MIDDLE OF THE LOTS
4. INSTALL CURB DOWELS TO MAINTAIN CURB INTEGRITY

4.		
3.		
2.		
1.		
REVISIONS		DATE



CITY OF VAUGHAN ENGINEERING STANDARD

**CATCHBASIN CURB DETAIL**

NOT TO SCALE      DESIGNED: \_\_\_\_\_

REVISION: \_\_\_\_\_      DATE: DEC. 2020

STD. DWG.

**R - 125**

**mm** DIMENSIONS IN MILLIMETRES  
EXCEPT AS NOTED

FILE: C:\Infrastructure\Delivery\Infrastructure Programming\PMO\City Standards\Design Criteria\2020-21\City Standards Update\Folders\Co\StandardDrawings\_CAD\_2021\R-126 - Curb and Subdrain Detail.dwg

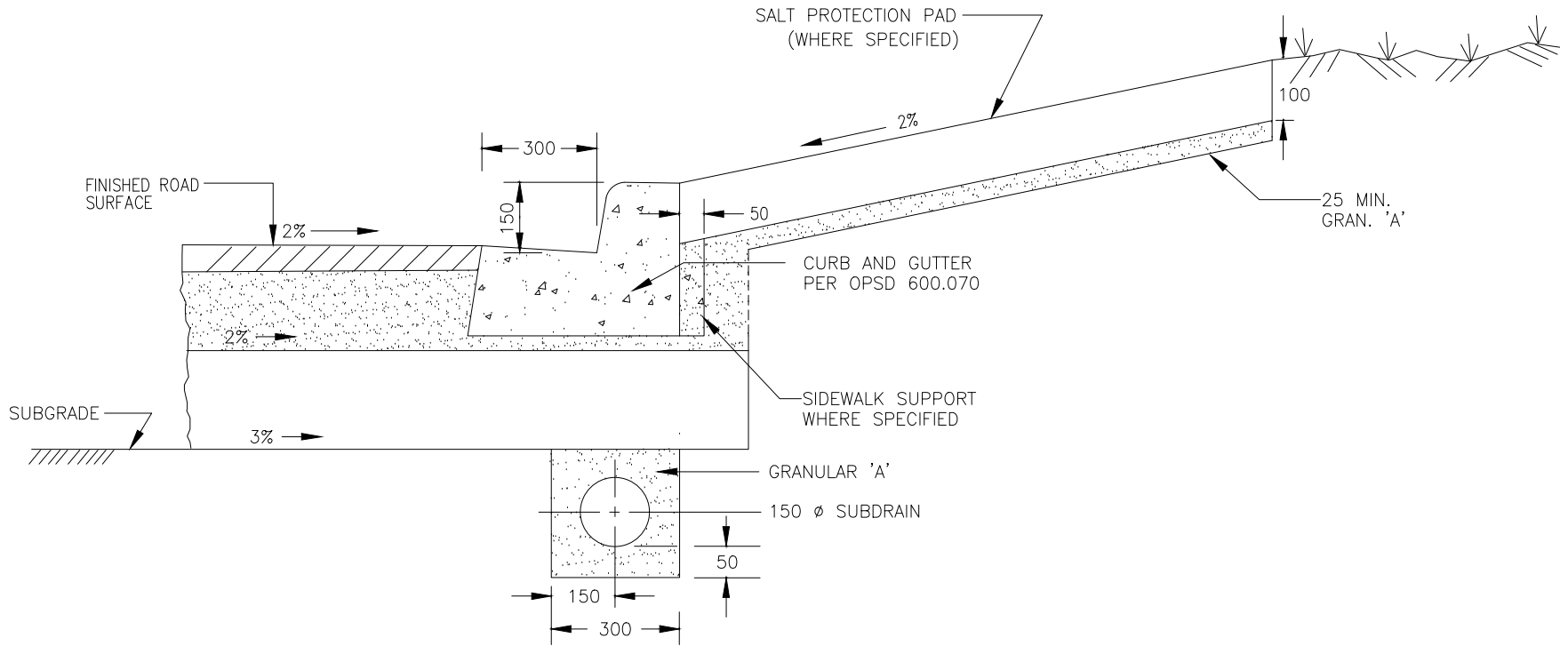

**mm** DIMENSIONS IN MILLIMETRES  
EXCEPT AS NOTED

**NOTES**

1. ALL SUBDRAIN CONNECTIONS TO BE MADE ON BOTH SIDES OF THE CATCH BASIN AND TO BE MORTARED AT THE INSIDE AND OUTSIDE OF THE CATCH BASIN WALLS UNLESS USING RUBBER GASKET CONNECTORS. THE SUBDRAIN SHALL BE CONTINUOUS PLUGGED WITH MANUFACTURED PLUG AT THE HIGH POINT WHERE THERE IS NO CATCHBASIN.
2. PIPE SHALL BE 150mm  $\phi$  POLYETHYLENE WRAPPED IN FILTER FABRIC.
3. FILTER FABRIC SHALL BE IN ACCORDANCE WITH ONTARIO PROVINCIAL STANDARD SPECIFICATIONS
4. SUBDRAIN SHALL BE PLACED UNDER ALL CURB AND GUTTER.

4.		
3.		
2.		
1.		
REVISIONS		DATE



CITY OF VAUGHAN ENGINEERING STANDARD

**CURB AND SUBDRAIN DETAIL**

NOT TO SCALE      DESIGNED: \_\_\_\_\_

REVISION: \_\_\_\_\_      DATE: DEC. 2020

STD. DWG.

**R - 126**



**R-127 - UNIT PAVER CROSSWALK DETAIL**  
CURRENTLY UNDER DEVELOPMENT

*Refer to 2004 Published Edition. Should drawing not be available, please contact the  
Development Engineering Department at [developmentengineering@vaughan.ca](mailto:developmentengineering@vaughan.ca)*

FILE: C:\Users\audiemop\CITY OF VAUGHAN\City Standards - General\Design Criteria 2025\Dev - Standards\CAD\R-128 - Sidewalk and Ramp.dwg

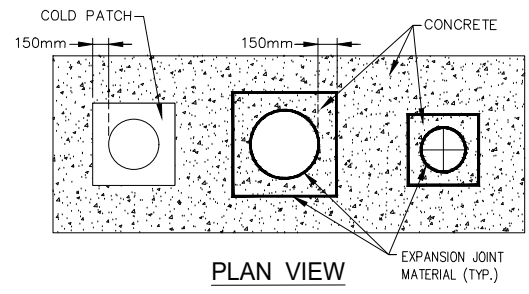
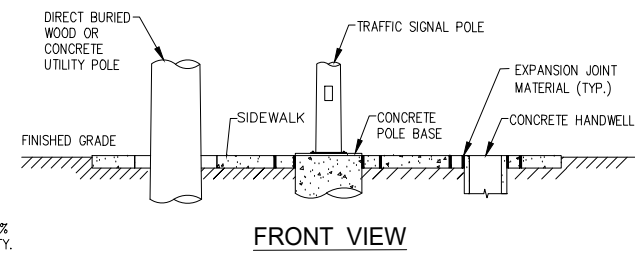
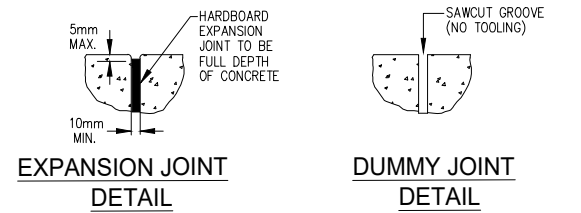
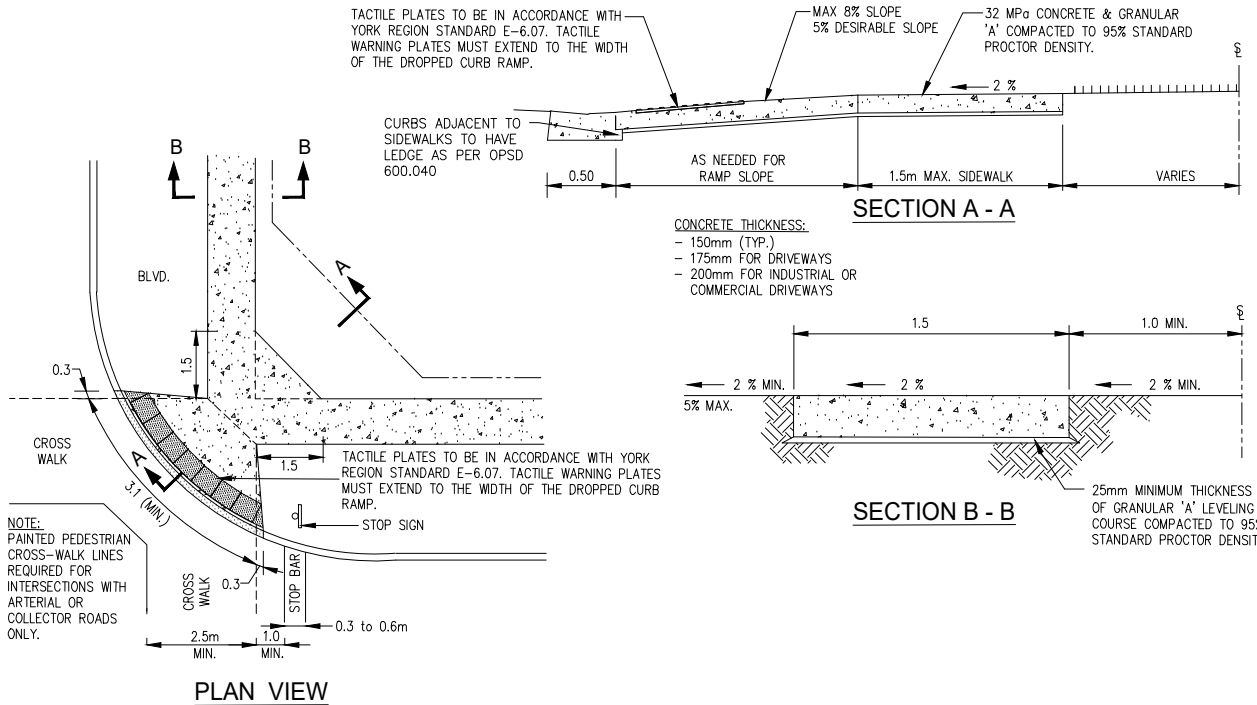

**NOTES**

1. CSA A23-1.00 CLASS C2 (32 MPa) CONCRETE, MAXIMUM CEMENT/WATER RATIO 0.45 WITH 6% AIR ENTRAINMENT ±1%.
2. WHERE SIDEWALK CONSTRUCTION INVOLVES CUT OR FILL, ADDITIONAL WIDENING MAY BE REQUIRED.
3. CONCRETE TO HAVE BROOM FINISH, PERPENDICULAR TO THE SIDEWALK LENGTH.
4. EXPANSION JOINTS TO BE LOCATED EVERY 6m AND WHERE CONCRETE PAVING ABUTS OTHER STRUCTURES OR BUILDINGS. THEY MUST BE OF A NON-EXTRUDED RESILIENT BITUMINOUS OR NON-BITUMINOUS MATERIAL - 10mm THICK.
5. INSTALL UTILITY ISOLATION JOINTS AT ALL NEW AND EXISTING UTILITY POLES, TRAFFIC SIGNAL POLES, HAND WELLS, MAINTENANCE HOLES, VALVE CHAMBERS, VALVE BOXES ACCORDANCE WITH YORK REGION STANDARD E-2.20 AND OPSD 310.040.
6. CONCRETE TO BE SPRAYED WITH WHITE PIGMENT CURING COMPOUND IMMEDIATELY AFTER FINISHING.
7. CAST IRON TACTILE PLATES TO BE IN ACCORDANCE WITH YORK REGION STANDARD E-6.07. TACTILE WARNING PLATES MUST EXTEND TO THE WIDTH OF THE DROPPED CURB RAMP.
8. ALL PERPENDICULAR TOOL MARKINGS FROM FINISHING TOOLS FOR EXPANSION JOINTS ARE TO BE BROOMED OUT SO NONE EXIST.
9. DUMMY JOINTS TO BE LOCATED AT INTERVALS OF 1.5m. THEY ARE TO BE SAWCUT TO 1/4 DEPTH OF CONCRETE, AFTER THE CONCRETE HAS PARTIALLY HARDENED.

**m** DIMENSIONS IN METRES EXCEPT AS NOTED

4.		
3.		
2.	REVISED STANDARD - TACTILE PLATE NOTE	OCT. 24
1.	REVISED STANDARD	NOV. 22
	REVISIONS	DATE



**CITY OF VAUGHAN ENGINEERING STANDARD**  
**SIDEWALK AND RAMP**  
**(LOCAL ROAD RETROFIT ONLY)**

NOT TO SCALE      DESIGNED: \_\_\_\_\_      STD. DWG.  
 REVISION:   2        DATE:   DEC. 2020        **R - 128**



**R-130 - BOLLARD DETAIL**  
CURRENTLY UNDER DEVELOPMENT

*Refer to 2004 Published Edition. Should drawing not be available, please contact the  
Development Engineering Department at [developmentengineering@vaughan.ca](mailto:developmentengineering@vaughan.ca)*

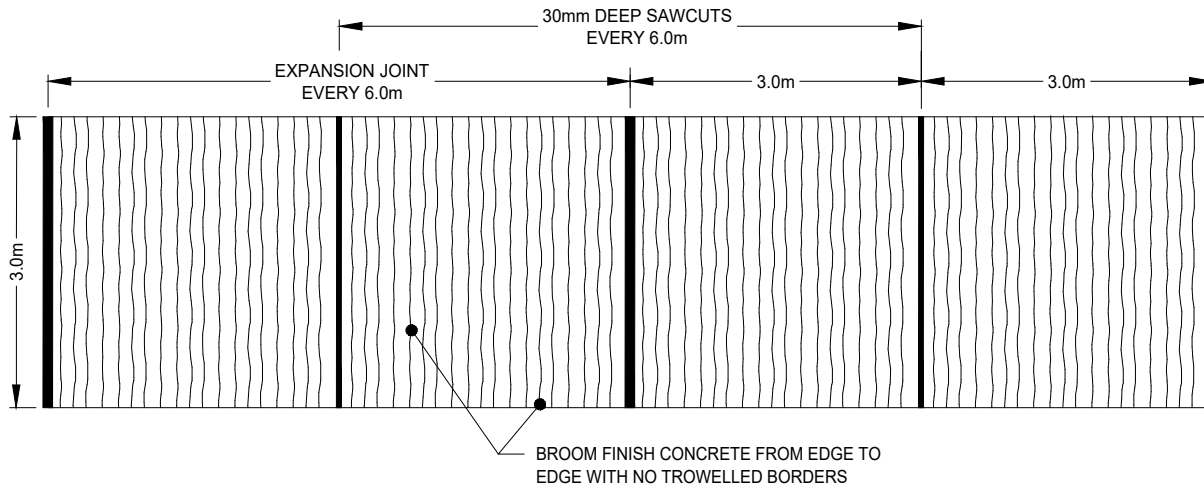

**PLAN VIEW**

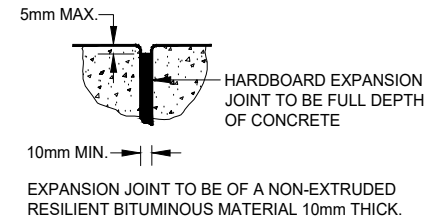

**EXPANSION JOINT DETAIL**

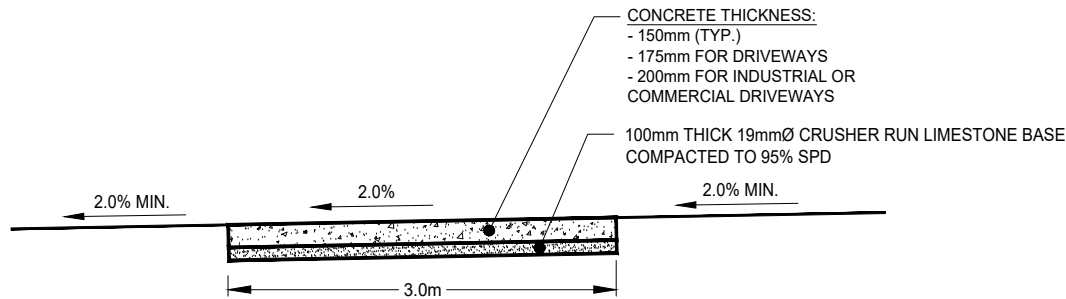

**SECTION VIEW**

**m** DIMENSIONS IN METRES EXCEPT AS NOTED

**NOTES**

1. CSA A23-1.00 CLASS C2 (32 MPa) CONCRETE, MAXIMUM CEMENT/WATER RATIO 0.45 WITH 6% AIR ENTRAINMENT ±1%.
2. CONCRETE TO BE SPRAYED WITH WHITE PIGMENT CURING COMPOUND IMMEDIATELY AFTER FINISHING.
3. INTERSECTION RAMPS WITH TACTILE PLATES SHALL BE BUILT AS PER CITY OF VAUGHAN SIDEWALK AND RAMP STANDARD DRAWING R-128.
4. ALL PERPENDICULAR TOOL MARKINGS FROM FINISHING TOOLS FOR EXPANSION JOINTS ARE TO BE BROOMED SO NONE EXIST.
5. THE USE OF CONCRETE MULTI-USE PATH IS SUBJECT TO APPROVAL OF THE CITY.

5.		
4.		
3.		
2.		
1.		
REVISIONS		DATE



CITY OF VAUGHAN ENGINEERING STANDARD

**CONCRETE MULTI-USE PATH  
DETAIL**

NOT TO SCALE      DESIGNED: \_\_\_\_\_  
REVISION: \_\_\_\_\_      DATE: MAY 2022

STD. DWG.  
**R - 131**

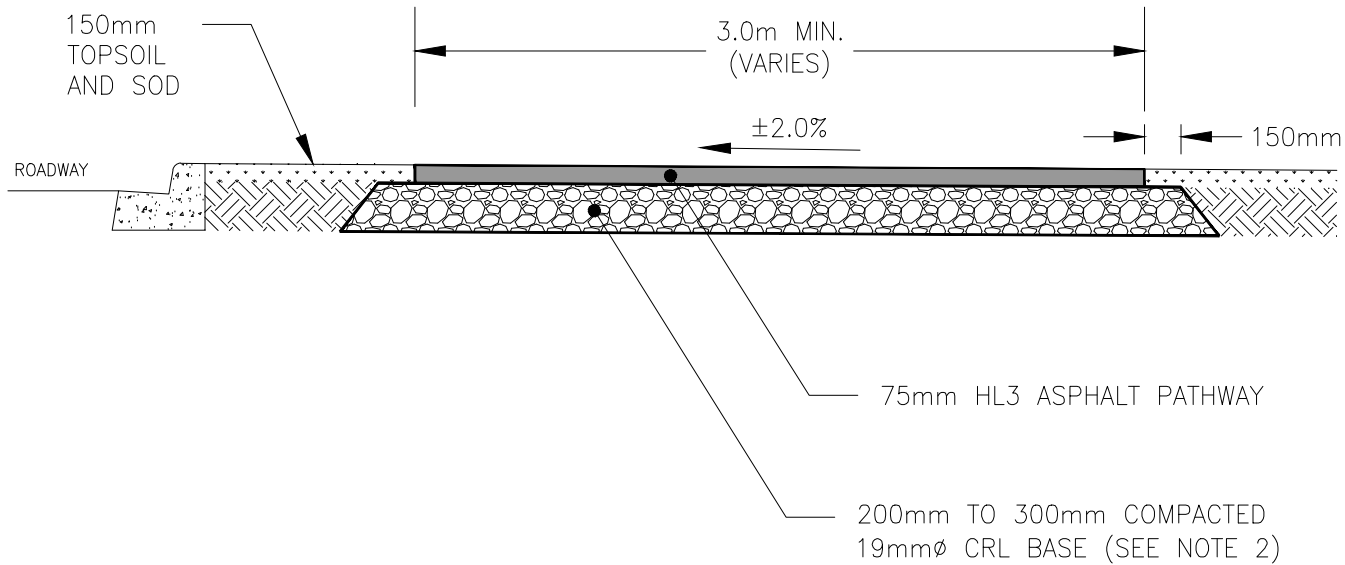

**NOTES**

1. PAVEMENT MARKINGS THROUGH INDUSTRIAL & COMMERCIAL DRIVEWAYS SHALL BE REQUIRED AS SPECIFIED.
2. GRANULAR AT EXISTING RESIDENTIAL DRIVEWAYS TO BE 300mm DEPTH AND ASPHALT 50mm HL8 BASE COURSE ASPHALT AND 25mm DEPTH HL-3F SURFACE COURSE ASPHALT.
3. A MULTI-USE OR CYCLE TRACK CROSSING THROUGH A INDUSTRIAL/COMMERCIAL/INSTITUTIONAL ENTRANCE SHALL HAVE 350mm COMPACTED DEPTH 50mm CRUSHER-RUN LIMESTONE, 125mm COMPACTED DEPTH 20mm CRUSHER RUN LIMESTONE BASE, 75mm DEPTH HL8 BASE COURSE ASPHALT AND 50mm DEPTH HL3 SURFACE COURSE ASPHALT.
4. ALL ASPHALT AND GRANULAR BASE THICKNESS SPECIFICATIONS ARE MINIMUM AFTER COMPACTION.
5. SLOPE SUBGRADE PARALLEL TO FINISHED GRADE (MIN. 2% SLOPE).
6. CONTRACTOR SHALL BE RESPONSIBLE FOR THE REMOVAL AND REPLACEMENT OF ANY UNSUITABLE SUBGRADE MATERIAL SUCH AS TOPSOIL. REMOVE ALL EXCAVATED MATERIAL AND DISPOSE OF OFF SITE.

**mm** DIMENSIONS IN MILLIMETRES  
EXCEPT AS NOTED

4.			
3.			
2.			
1.			
REVISIONS		APR'D	DATE



**CITY OF VAUGHAN ENGINEERING STANDARD**  
**ACTIVE TRANSPORTATION FACILITY**  
**(MULTI-USE ASPHALT PATHWAY)**

NOT TO SCALE	APPROVED: _____	STD. DWG.
DESIGNED: _____	DATE: MAY 2022	<b>R - 132</b>

Acad File: C:\Infrastructure Delivery\Infrastructure Programming\VAO\City Standards\Design Criteria 2020\City Standards Update Folder\CityStandardsDrawings\_CAD\_2022\R-133 - Pedestrian & Cycling Facilities.dwg

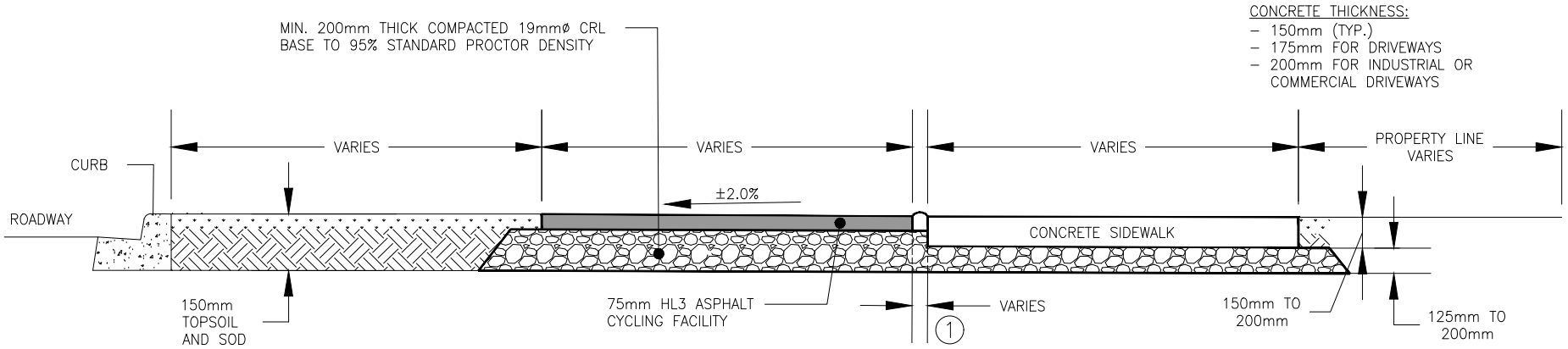

**CONCRETE THICKNESS:**  
 - 150mm (TYP.)  
 - 175mm FOR DRIVEWAYS  
 - 200mm FOR INDUSTRIAL OR COMMERCIAL DRIVEWAYS

**CYCLING FACILITY NOTES:**

1. BUFFER BETWEEN CYCLING FACILITY AND SIDEWALK PER ONTARIO TRAFFIC MANUAL BOOK 18 (CONTINUOUS BEVELLED CURB OR TACTILE BUFFER PER OTM BOOK 18)
2. PAVEMENT MARKINGS THROUGH INDUSTRIAL & COMMERCIAL DRIVEWAYS SHALL BE REQUIRED AS SPECIFIED.
3. GRANULAR AT EXISTING RESIDENTIAL DRIVEWAYS TO BE 300mm DEPTH AND ASPHALT 50mm HL8 BASE COURSE ASPHALT AND 25mm DEPTH HL-3F SURFACE COURSE ASPHALT.
4. A MULTI-USE OR CYCLE TRACK CROSSING THROUGH A INDUSTRIAL/COMMERCIAL/INSTITUTIONAL ENTRANCE SHALL HAVE 350mm COMPACTED DEPTH 50mm CRUSHER-RUN LIMESTONE, 125mm COMPACTED DEPTH 20mm CRUSHER RUN LIMESTONE BASE, 75mm DEPTH HL8 BASE COURSE ASPHALT AND 50mm DEPTH HL3 SURFACE COURSE ASPHALT.
5. ALL ASPHALT AND GRANULAR BASE THICKNESS SPECIFICATIONS ARE MINIMUM AFTER COMPACTION.

**SIDEWALK NOTES:**

1. CSA A23-1.00 CLASS C2 (32 MPa) CONCRETE, MAXIMUM CEMENT/WATER RATIO 0.45 WITH 6% AIR ENTRAINMENT ±1%.
2. WHERE SIDEWALK CONSTRUCTION INVOLVES CUT OR FILL, ADDITIONAL WIDENING MAY BE REQUIRED.
3. CONCRETE TO HAVE BROOM FINISH, PERPENDICULAR TO THE SIDEWALK LENGTH.
4. EXPANSION JOINTS TO BE LOCATED EVERY 6m AND WHERE CONCRETE PAVING ABUTS OTHER STRUCTURES OR BUILDINGS. THEY MUST BE OF A NON-EXTRUDED RESILIENT BITUMINOUS OR NON-BITUMINOUS MATERIAL - 10mm THICK.
5. DUMMY JOINTS TO BE LOCATED AT INTERVALS OF 1.5m. THEY ARE TO BE SAWCUT TO 1/4 DEPTH OF CONCRETE, AFTER THE CONCRETE HAS PARTIALLY HARDENED.
6. CONCRETE TO BE SPRAYED WITH WHITE PIGMENT CURING COMPOUND IMMEDIATELY AFTER FINISHING.
7. CAST IRON TACTILE PLATES TO BE IN ACCORDANCE WITH YORK REGION STANDARD.
8. ALL PERPENDICULAR TOOL MARKINGS FROM FINISHING TOOLS FOR EXPANSION JOINTS ARE TO BE BROOMED OUT SO NONE EXIST.

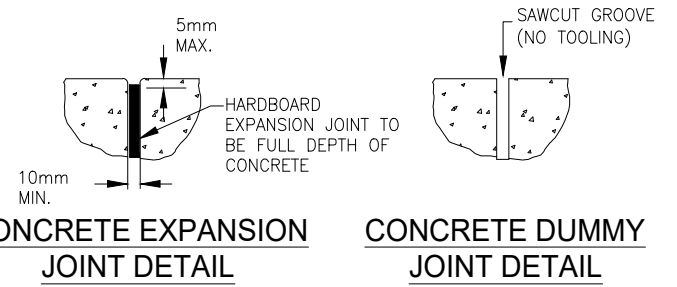

**mm** DIMENSIONS IN MILLIMETRES EXCEPT AS NOTED

4.			
3.			
2.			
1.			
REVISIONS			APR'D DATE



**CITY OF VAUGHAN ENGINEERING STANDARD**

**PEDESTRIAN AND CYCLING FACILITIES**

NOT TO SCALE      APPROVED: \_\_\_\_\_  
 DESIGNED: \_\_\_\_\_      DATE: MAY 2022

STD. DWG.  
**R - 133**

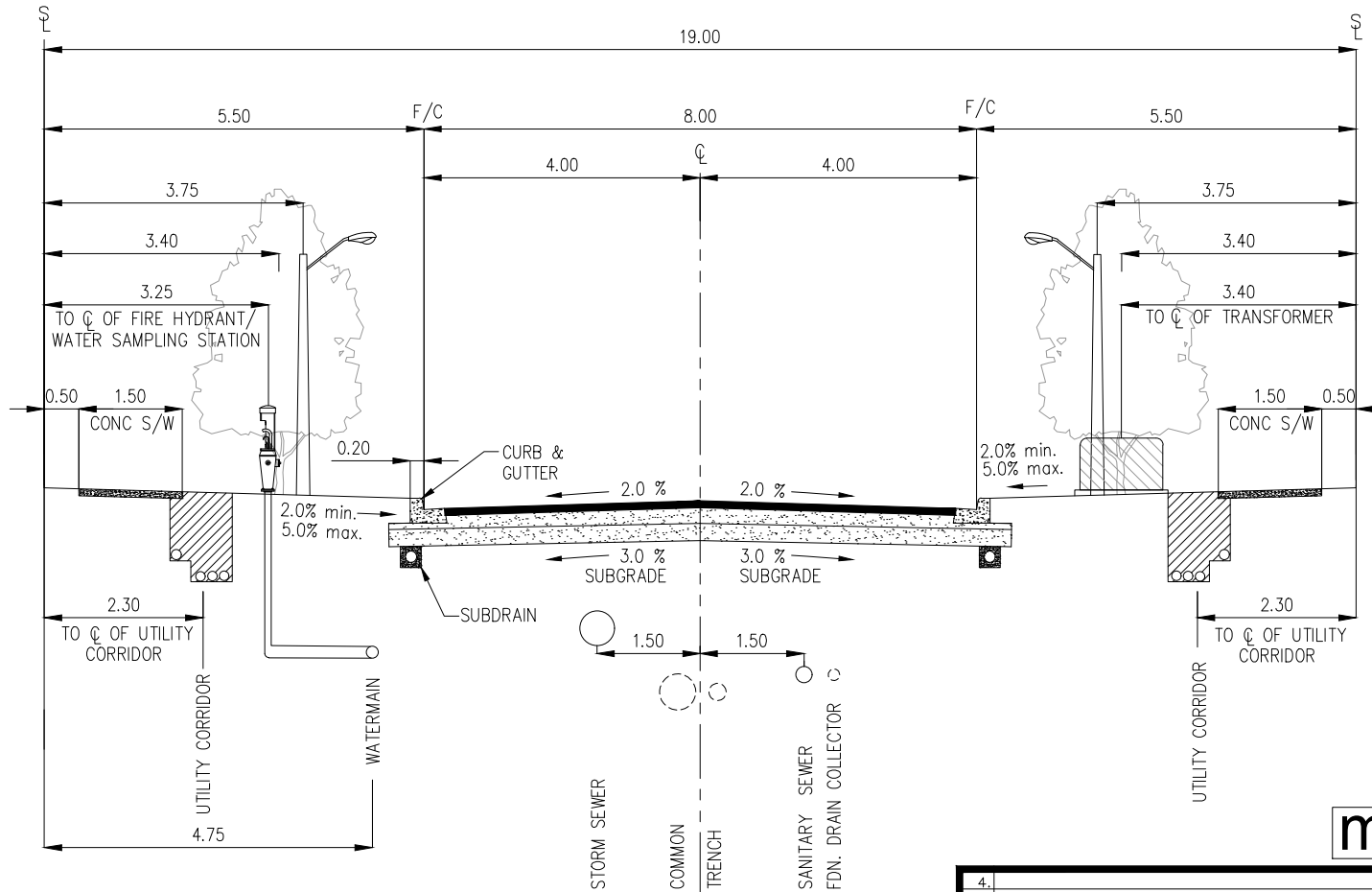

**m** DIMENSIONS IN METRES  
EXCEPT AS NOTED

**NOTES**

1. PAVEMENT WIDTH IS DESIGNED TO ACCOMMODATE 2 TRAVEL LANES WITH 1 PARKING LANE.
2. PAVEMENT DESIGN SHALL CONFORM TO MINIMUM CITY STANDARDS AND/OR APPROVED GEOTECHNICAL REPORT.
3. ACTIVELY GROWING No. 1 NURSERY SOD TO BE LAID ON 150mm OF TOPSOIL, PROPERLY GRADED AND ROLLED.
4. DEPTH OF COVER ON ALL MUNICIPAL INFRASTRUCTURE SHALL CONFORM TO MINIMUM CITY STANDARDS.
5. IF TRANSFORMER IS ON SIDE LOT, TURN FOUNDATION 90° TO FACE ONCOMING TRAFFIC INSTALL 1.70m TO CENTER OF FOUNDATION.
6. TRANSFORMER FOUNDATION TO ABUT EDGE OF TRENCH.

4.		
3.		
2.		
1.	STANDARD CREATED	JAN. 21
	REVISIONS	DATE



CITY OF VAUGHAN ENGINEERING STANDARD

**MAJOR LOCAL ROAD**  
**19m R.O.W. - 8m PAVEMENT**

NOT TO SCALE      DESIGNED: ENG. DEPT.

REVISION: 01      DATE: JAN. 2021

STD. DWG.  
**R - 134**



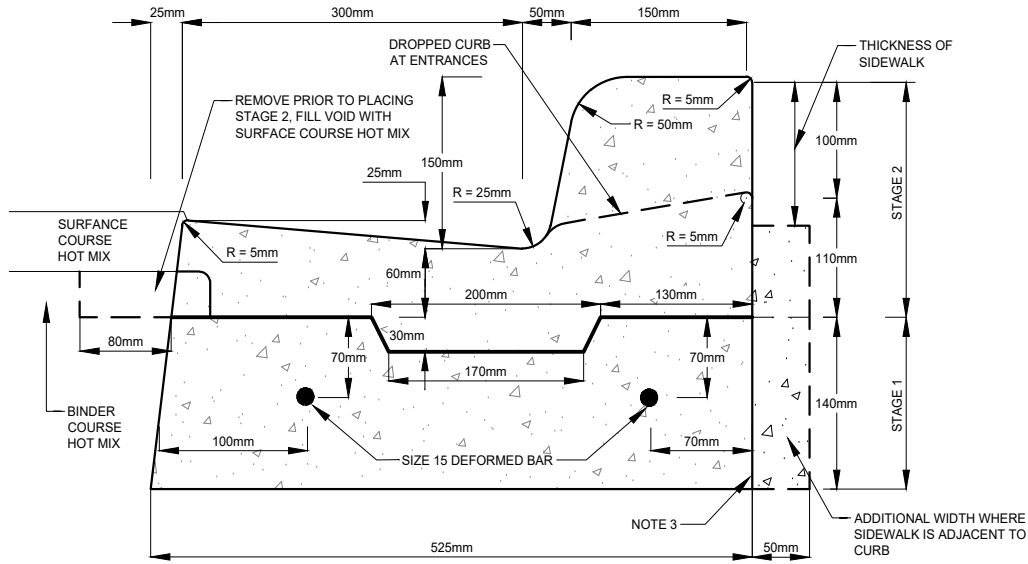

**SECTION A-A**

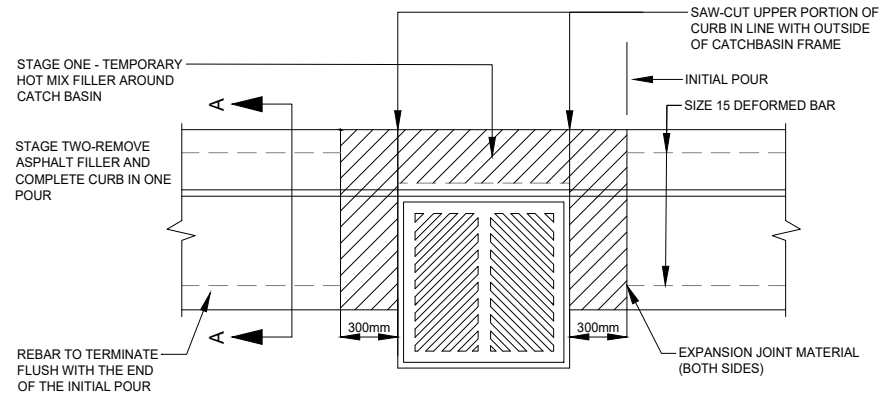

**PLAN VIEW**

**mm** DIMENSIONS IN MILLIMETERS EXCEPT AS NOTED

**NOTES:**

1. FLEXIBLE AND COMPOSITE PAVEMENT SHALL BE 5mm ABOVE THE ADJACENT EDGE OF GUTTER.
2. WHERE THE SIDEWALK IS CONTINUOUS TO THE CURB, ENTRANCES LOWER THE HEIGHT OF THE ADDITIONAL CONCRETE AT THE REAR OF THE CURB TO 150mm.
3. FOR SLIPFORMING PROCEDURE, A 5% BATTER IS ACCEPTABLE.
4. TREATMENT AT ENTRANCES SHALL CONFORM WITH OPSD-351.01.
5. OUTLET TREATMENT SHALL CONFORM WITH OPSD-610 SERIES.
6. THE LENGTH OF TRANSITION FROM ONE CURB TO ANOTHER SHALL BE 3.0m. EXCEPT IN CONJUNCTION WITH GUIDE RAIL, IT SHALL CONFORM TO OPSD-900 SERIES.
7. ALL DIMENSIONS ARE IN MILLIMETERS UNLESS OTHERWISE SHOWN.
8. BASE CURB IS TO BE FLUSHED THEN BLOWN OFF WITH PRESSURE AIR TO ENSURE A CLEAN DRY SURFACE.
9. ALL CONCRETE CSA, C-2, 32MPa.

4.		
3.		
2.		
1.		
REVISIONS		DATE



CITY OF VAUGHAN ENGINEERING STANDARD

**2-STAGE CURB AND GUTTER**

NOT TO SCALE      DRAWN BY: PC      STD. DWG.  
 REVISION: \_\_\_\_\_      DATE: JUN. 2023      **R - 135**

FILE: C:\Infrastructure\Delivery\Infrastructure Programming\PMO\City Standards\Design Criteria\2020-21\City Standards\Update Folder\CoS\StandardDrawings\_CAD\_2021\S-101 - Outfall Grate.dwg

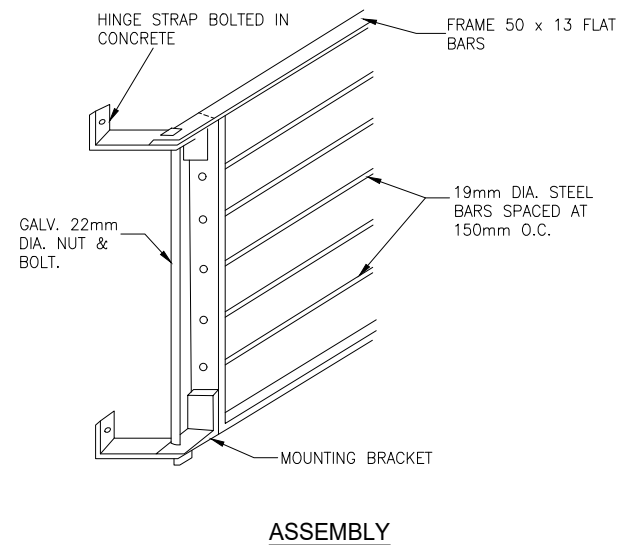
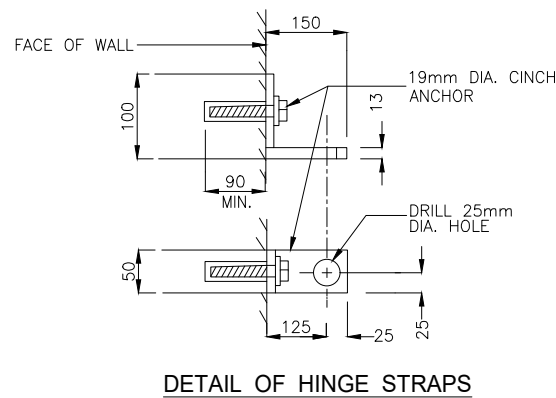
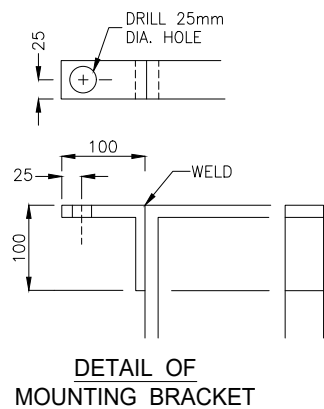
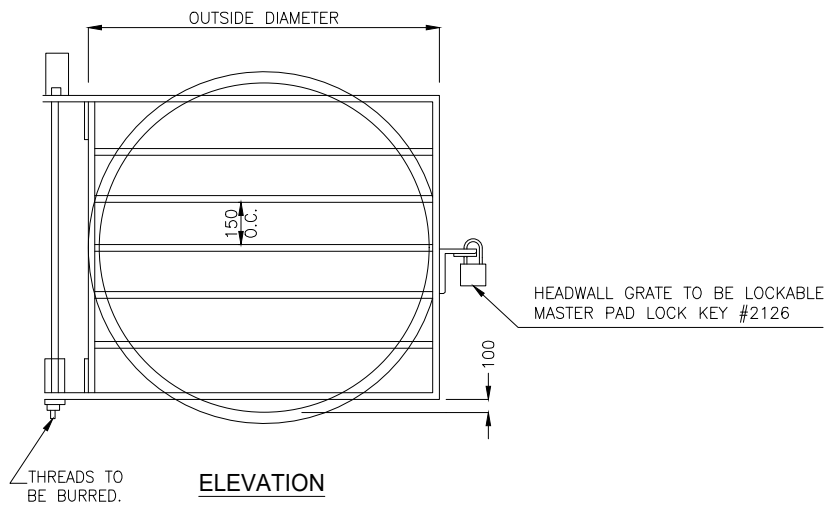

**NOTES**

1. FRAME, HINGE, STRAP, MOUNTING BRACKET AND STEEL RODS TO BE MEDIUM GRADE STEEL.
2. THE ENTIRE GRATE SHALL BE HOT DIPPED GALVANIZED.
3. ALL WELDS USED IN THE MANUFACTURE OF GRATES SHALL BE FULL STRENGTH WELDS.
4. ALL BOLTS, NUTS AND WASHERS SHALL BE STAINLESS STEEL.
5. OUTFALL LARGER THAN 900mmØ SHALL BE DESIGNED SITE SPECIFICALLY AND APPROVED BY THE CITY.

**mm** DIMENSIONS IN MILLIMETRES EXCEPT AS NOTED

4.		
3.		
2.		
1.		
REVISIONS		DATE



CITY OF VAUGHAN ENGINEERING STANDARD

**OUTFALL GRATE  
MAX. 900mmØ**

NOT TO SCALE      DESIGNED: \_\_\_\_\_  
 REVISION: \_\_\_\_\_      DATE: DEC. 2020

STD. DWG.  
**S - 101**

FILE: C:\Infrastructure\Delivery\Infrastructure Programming\PMO\City Standards\Design Criteria\2020-21\City Standards Update\Folders\CoS\StandardDrawings\_CAD\_2021\S-102 - Inlet Grate.dwg

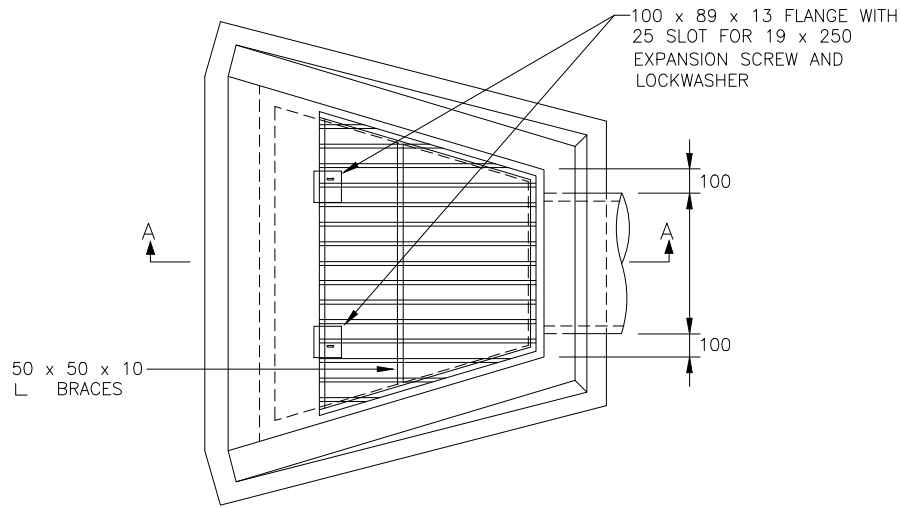

PLAN

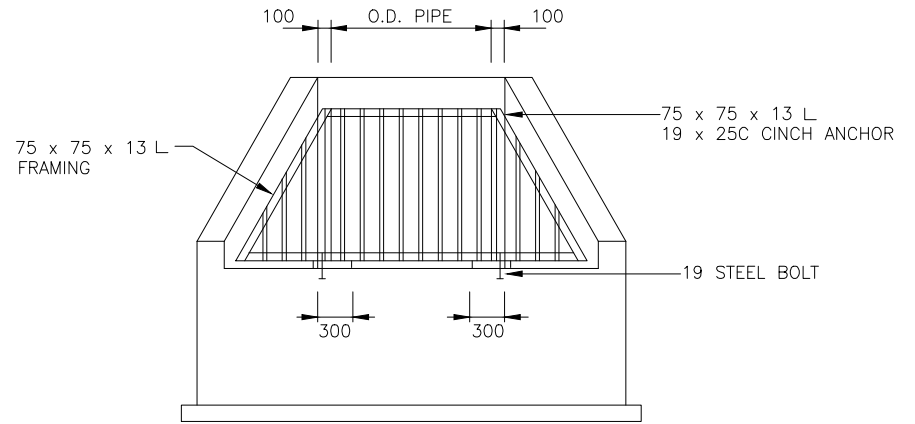

ELEVATION

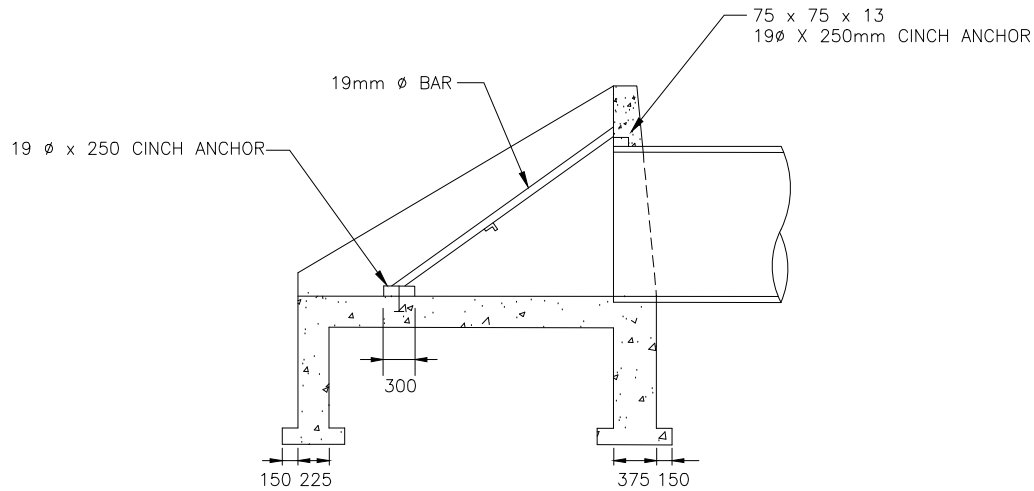

SECTION A-A

NOTES

1. ALL STEEL USED SHALL BE MEDIUM GRADE.
2. THE ENTIRE GRATE SHALL BE HOT DIPPED GALVANIZED.
3. ALL BOLTS, NUTS AND WASHERS SHALL BE STAINLESS STEEL.
4. ALL WELDS USED IN THE MANUFACTURE OF THE GRADES SHALL BE CONTINUOUS FILET WELD 6mm THROAT WIDTH.
5. GRATING TO BE SPECIFICALLY DESIGNED FOR PIPES 1.0m DIA. OR LARGER.

4.		
3.		
2.		
1.		
REVISIONS		DATE



CITY OF VAUGHAN ENGINEERING STANDARD

INLET GRATE

**mm** DIMENSIONS IN MILLIMETRES  
EXCEPT AS NOTED

NOT TO SCALE      DESIGNED: \_\_\_\_\_

REVISION: \_\_\_\_\_      DATE: DEC. 2020

STD. DWG.

S - 102

FILE: C:\Infrastructure\Delivery\Infrastructure Programming\PMO\City Standards\Design Criteria\2020-21\City Standards Update\Folder\Co\StandardDrawings\_CAD\_2021\S-103 - Rear Yard Catchbasin Grate.dwg

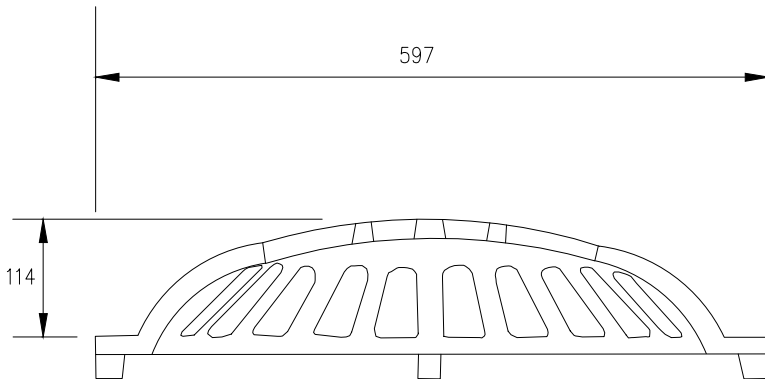
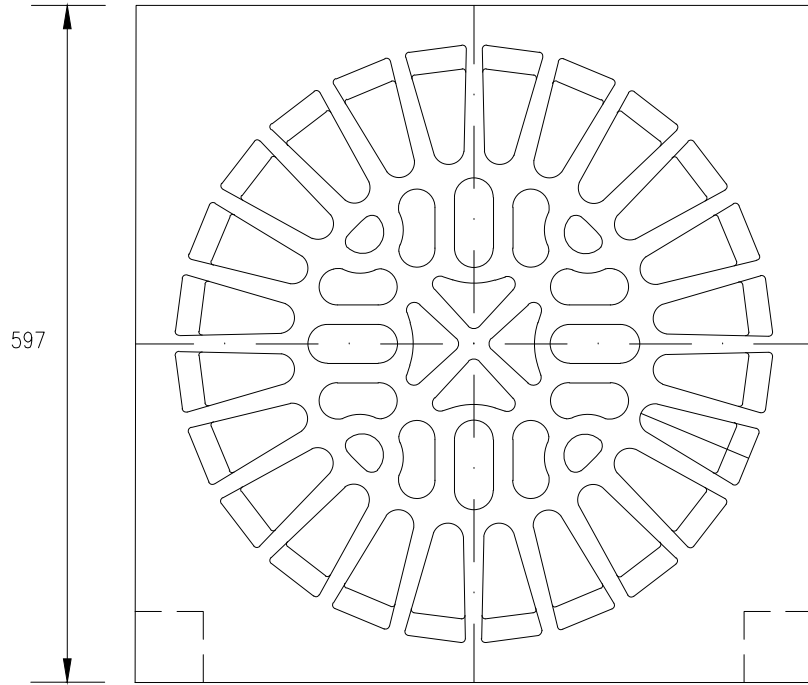

**mm** DIMENSIONS IN MILLIMETRES  
EXCEPT AS NOTED

4.		
3.		
2.		
1.		
REVISIONS		DATE



CITY OF VAUGHAN ENGINEERING STANDARD

**REAR YARD CATCHBASIN GRATE**

NOT TO SCALE	DESIGNED: _____	STD. DWG. <b>S - 103</b>
REVISION: _____	DATE: DEC. 2020	

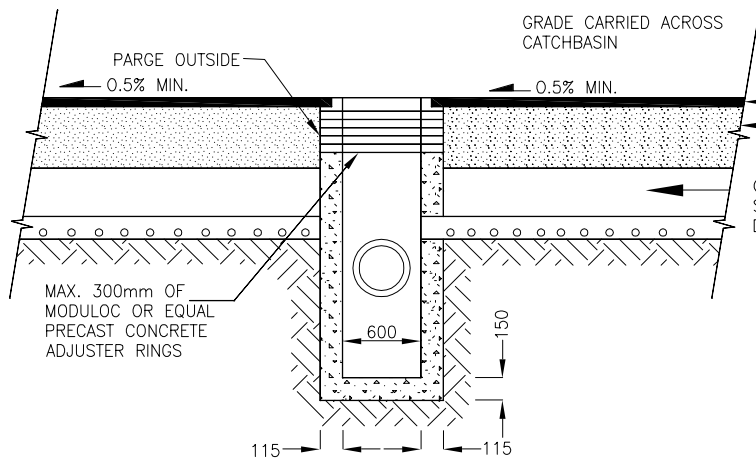

**SINGLE CATCHBASIN**

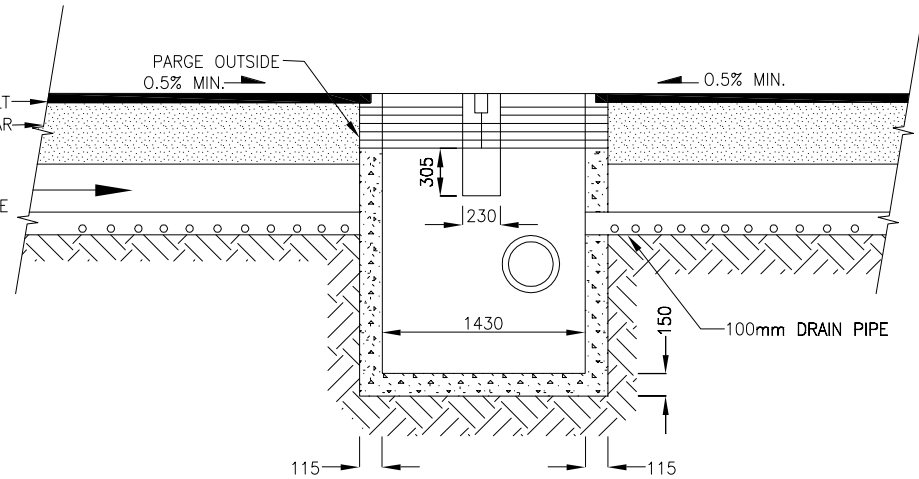

**DOUBLE CATCHBASIN**

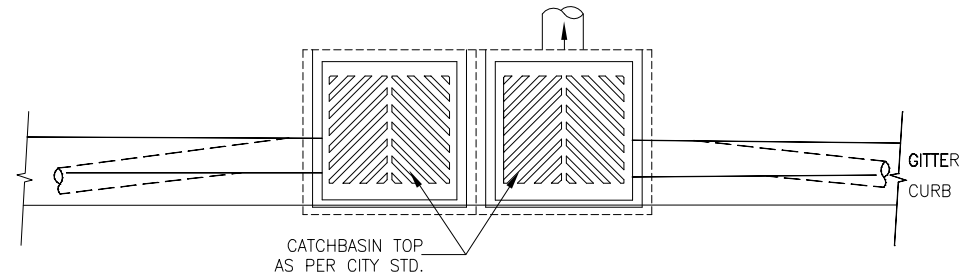
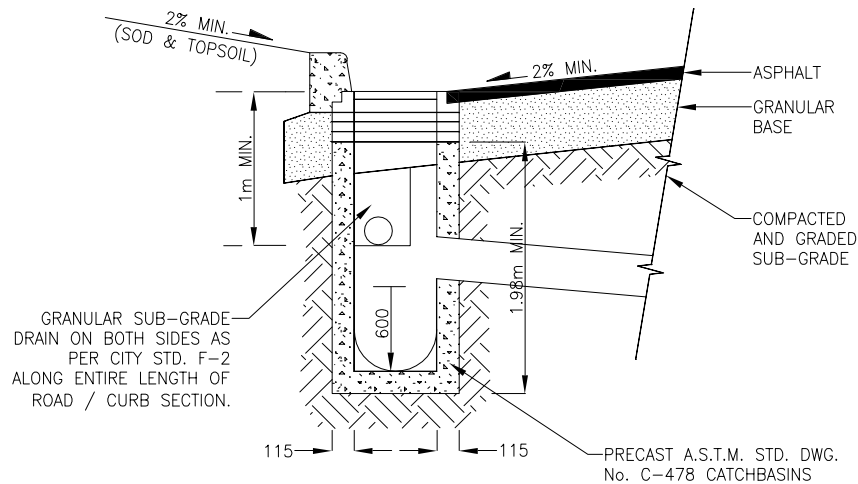

**NOTES**

1. ALL WEEP HOLES AND LIFT HOLES TO BE PLUGGED AND MORTARED.
2. ALL GRANULAR BACKFILL TO BE PLACED TO 300mm MINIMUM THICKNESS ON ALL SIDES.
3. ALL GRANULAR BACKFILL TO BE COMPACTED TO 95% S.P.D.

**mm** DIMENSIONS IN MILLIMETRES  
EXCEPT AS NOTED

4.		
3.		
2.		
1.		
REVISIONS		DATE

**City of Vaughan**  
*The City Above Toronto*

**ENGINEERING  
DEPARTMENT**

CITY OF VAUGHAN ENGINEERING STANDARD

**CATCHBASINS**

NOT TO SCALE      DESIGNED: ENG. DEPT.  
REVISION: \_\_\_\_\_      DATE: MARCH 2004

STD. DWG.  
**K - 4**

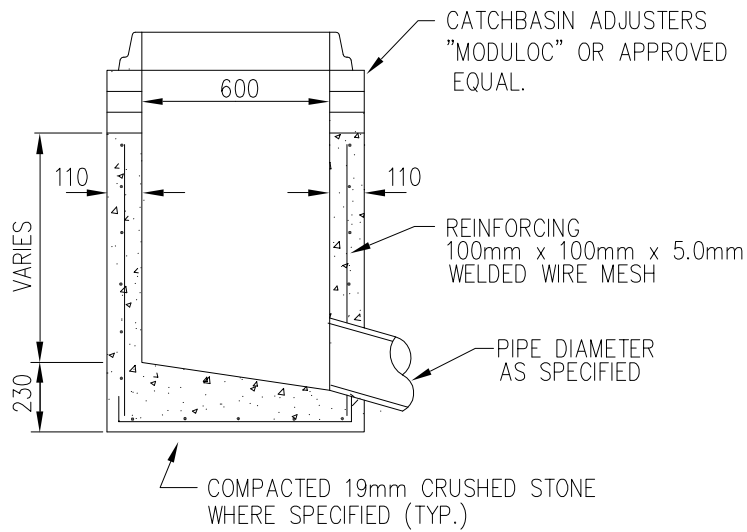

**SECTION A-A**

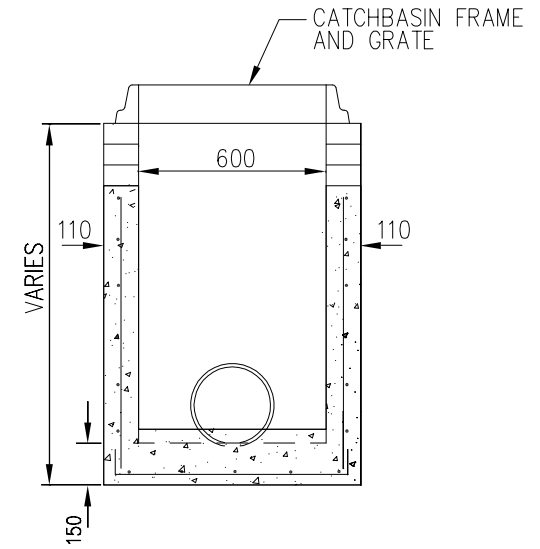

**SECTION B-B**

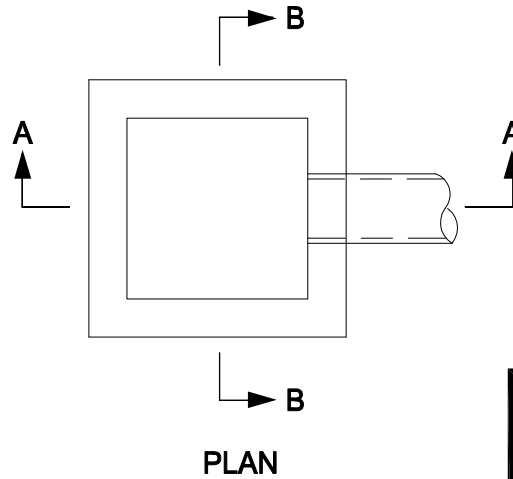

**PLAN**

**NOTES**

1. CATCHBASIN ADJUSTERS TO BE INSTALLED AS PER MANUFACTURERS RECOMMENDATIONS. MINIMUM UNIT THICKNESS TO BE 50mm.
2. ALL JOINTS AND LIFTING HOLES TO BE COMPLETELY FILLED WITH A 1:3 MORTAR MIX AND POINTED BEFORE BACKFILLING.
3. REAR YARD CATCHBASINS TO BE OF THIS TYPE.

**mm** DIMENSIONS IN MILLIMETRES  
EXCEPT AS NOTED

4.		
3.		
2.		
1.		
REVISIONS		DATE



CITY OF VAUGHAN ENGINEERING STANDARD

**PRECAST CATCHBASIN  
WITHOUT SUMP**

NOT TO SCALE      DESIGNED: ENG. DEPT.  
REVISION: \_\_\_\_\_      DATE: MARCH 2004

STD. DWG.  
**K-5**

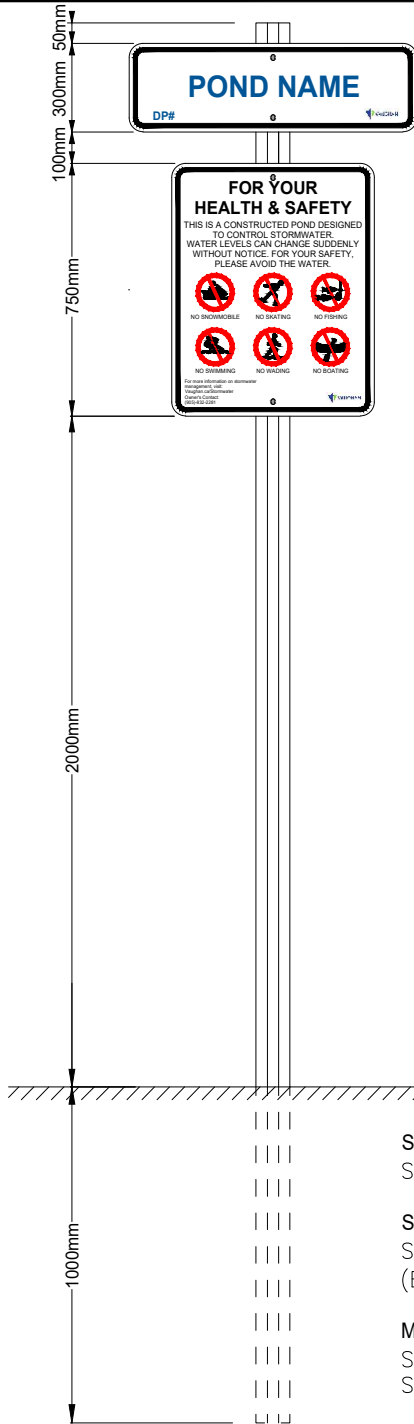

**SIGN REQUIREMENTS**

SIGN(S) MUST BE PLACED AT ALL POND ENTRANCES.

**SIGNAGE FACE**

SIGN(S) TO BE MANUFACTURED USING REFLECTIVE FINISH (ENGINEER GRADE), WITH TOP AND BOTTOM MOUNT HOLES.

**MOUNTING**

SIGN(S) TO BE MOUNTED TO 3.8m U-CHANNEL GALVANIZED STEEL POST.

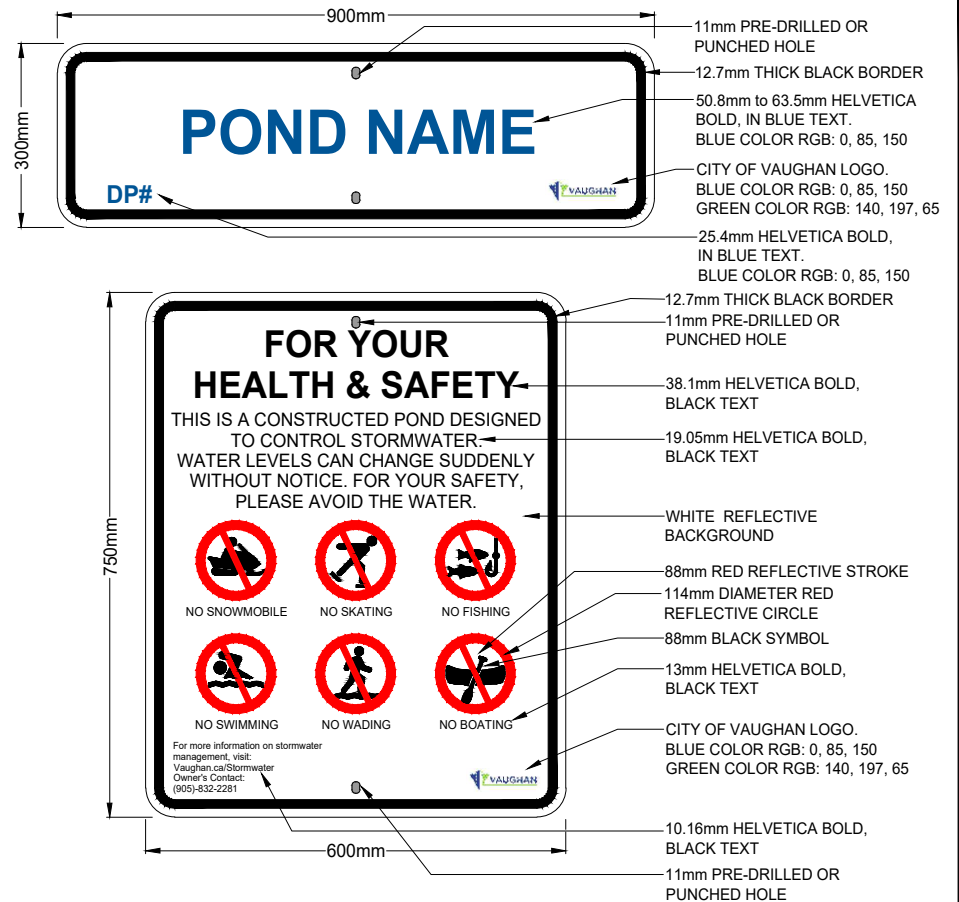

4.		
3.		
2.		
1.	REVISED/UPDATED SIGN STANDARD	07/24
	REVISIONS	DATE
<b>CITY OF VAUGHAN ENGINEERING STANDARD</b>		
<b>STORM WATER FACILITY POND WARNING SIGN</b>		
NOT TO SCALE	DESIGNED: _____	STD. DWG.
REVISION: 1	DATE: DEC. 2020	<b>S-106</b>

FILE: C:\Infrastructure\Delivery\Infrastructure Programming\PMO\City Standards\Design Criteria\2020-21\City Standards Update\Folders\CoS\StandardDrawings\_CAD\_2021\S-107 - Safety Station for Ponds & Waterways.dwg

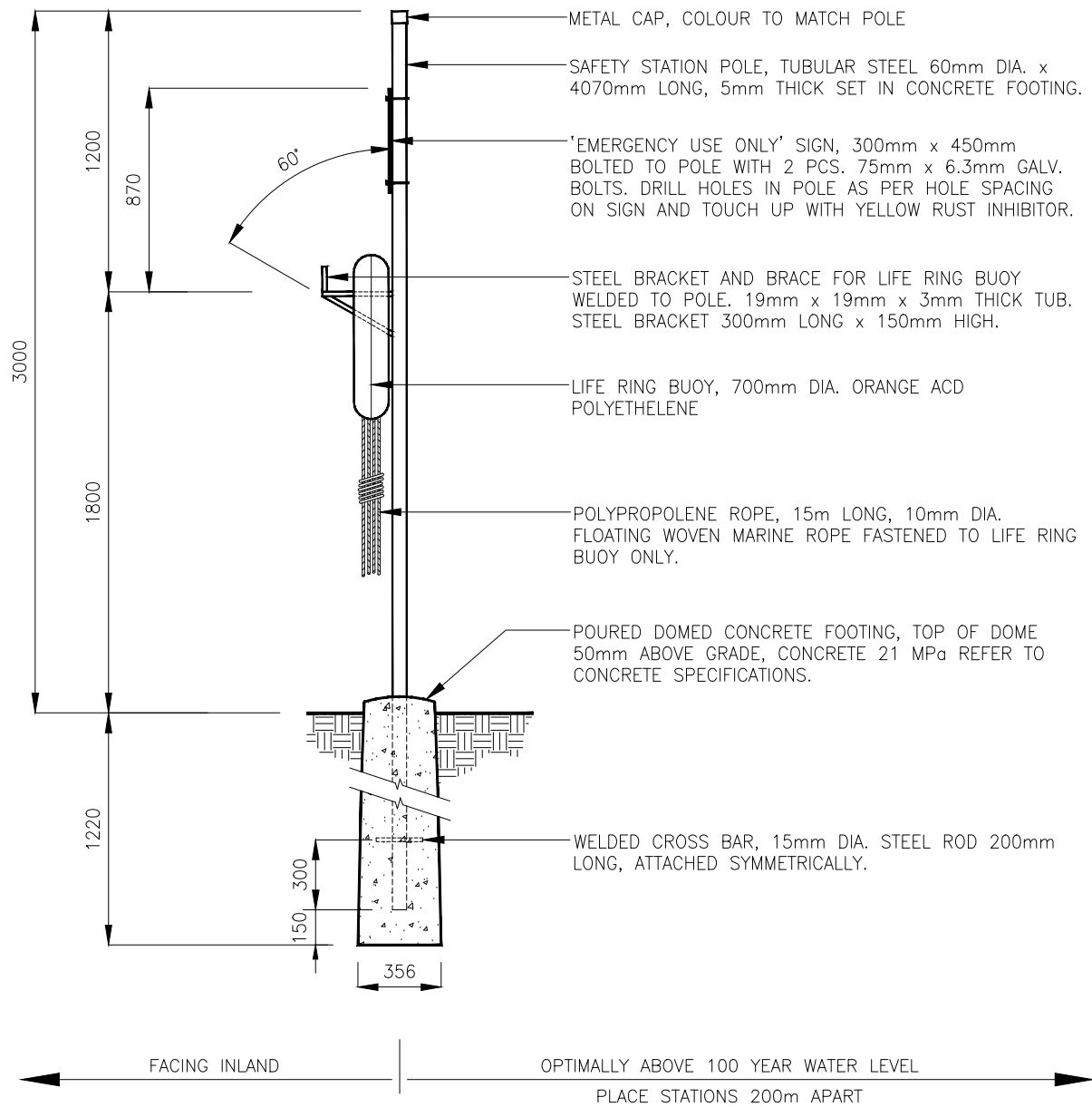

**NOTES**

1. FINISH OF POST AND ALL OTHER STEEL COMPONENTS AND FITTINGS TO BE SAFETY YELLOW GLOSS ENAMEL POWDER COAT APPLICATION. PRIOR TO POWDER COATING, ALL SURFACES TO BE CHEMICALLY CLEANED AND TREATED WITH PARKER BONDERITE AND CHLOROTHENE SOLVENT OR APPROVED EQUAL. POWDER COATING MUST BE A POLYESTER 2000 SERIES APPLIED IN A THICKNESS OF 4-5 MILS BY ELECTROSTATIC COAT AND OVEN CURED TO A SMOOTH AND EVEN SURFACE.
2. NO PLASTIC COMPONENTS ARE TO BE USED EXCEPT WHERE NOTED.

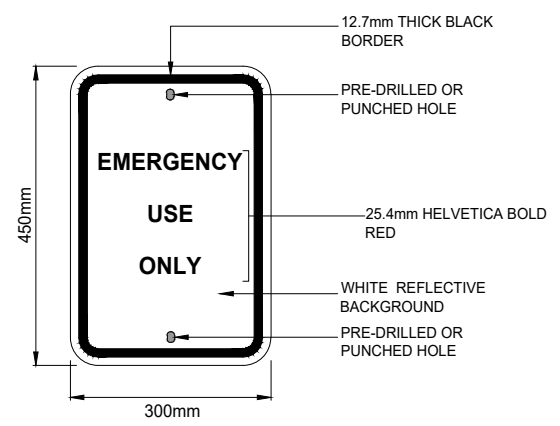

**mm** DIMENSIONS IN MILLIMETRES EXCEPT AS NOTED

4.		
3.		
2.		
1.		
REVISIONS		DATE



CITY OF VAUGHAN ENGINEERING STANDARD

**SAFETY STATION FOR PONDS AND WATERWAYS**

NOT TO SCALE      DESIGNED: \_\_\_\_\_      STD. DWG. S - 107

REVISION: \_\_\_\_\_      DATE: DEC. 2020



## **S-108 - SIDE INLET CATCHBASIN DETAILS**

CURRENTLY UNDER DEVELOPMENT

*Refer to 2004 Published Edition. Should drawing not be available, please contact the  
Development Engineering Department at [developmentengineering@vaughan.ca](mailto:developmentengineering@vaughan.ca)*

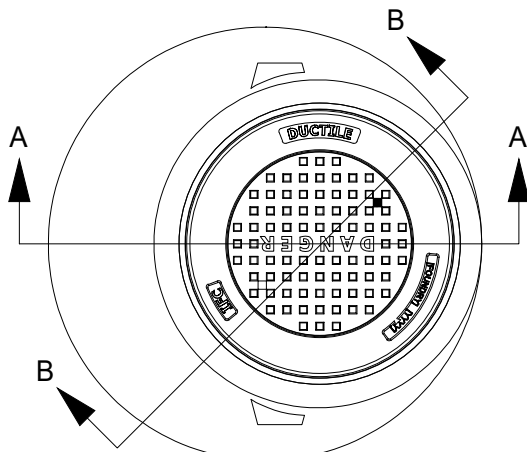

TOP VIEW

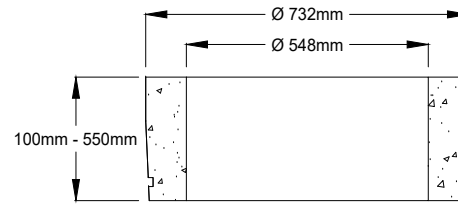

CONCRETE ADJUSTMENT UNIT

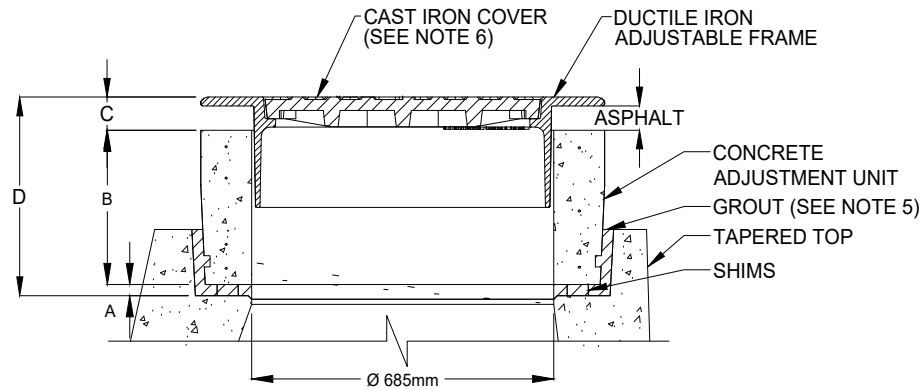

SECTION B-B

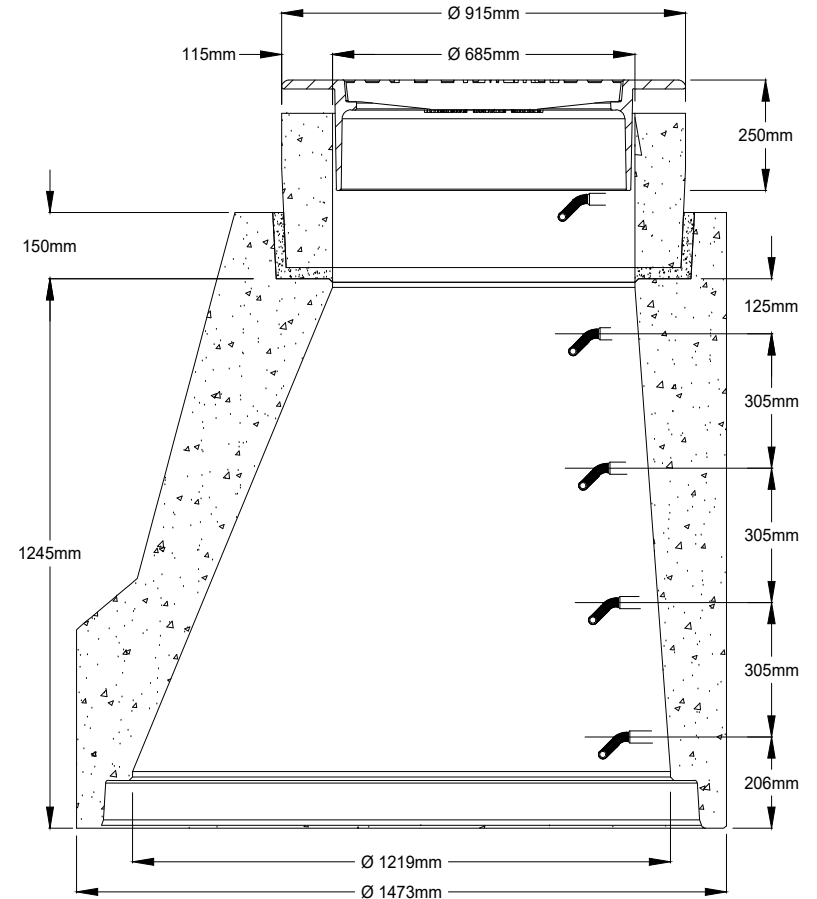

SECTION A-A

**mm** DIMENSIONS IN MILLIMETRES EXCEPT AS NOTED

DIMENSION	NOTES
A	ADJUSTMENT RANGE: 25mm - 100mm
B	STANDARD HEIGHT, CONCRETE ADJUSTMENT UNIT: 350mm. ALSO AVAILABLE: 100, 150, 200, 250, 300, 400, 450, 500, 550mm
C	DUCTILE IRON FRAME ADJUSTMENT RANGE: 70 - 200 mm.
D	OVERALL ADJUSTMENT: MIN 195 mm (USING 100mm C.A.U.) AND MAX 850 mm (USING 550mm C.A.U.)

**NOTES:**

1. MINIMUM CONCRETE STRENGTH AT 28 DAYS: 30 MPa.
2. REINFORCEMENT: AS PER CSA A257.4 - 09.
3. 25 mm MINIMUM COVER ON ALL REINFORCING STEEL.
4. CONCRETE ADJUSTMENT UNIT CAN BE ORIENTED TO SUIT HEIGHT AND ANGLE REQUIRED. UNIT DEPICTED IS 350mm.
5. GROUT REQUIREMENTS: NON-SHRINK; MINIMUM 50 MPa at 28 DAYS; TO BE INSTALLED ONLY AS PER MANUFACTURER APPLICATION GUIDELINES.
6. COVER DEPICTED IS PER OPSD 401.01, TYPE A. OTHER OPS-COMPLIANT COVERS AVAILABLE.

4.		
3.		
2.		
1.		
REVISIONS		DATE



**CITY OF VAUGHAN ENGINEERING STANDARD  
IFC MAINTENANCE HOLE  
TAPERED TOP ASSEMBLY**

NOT TO SCALE      DESIGNED: \_\_\_\_\_

REVISION: \_\_\_\_\_      DATE: JUN. 2023

STD. DWG.

**S - 109**

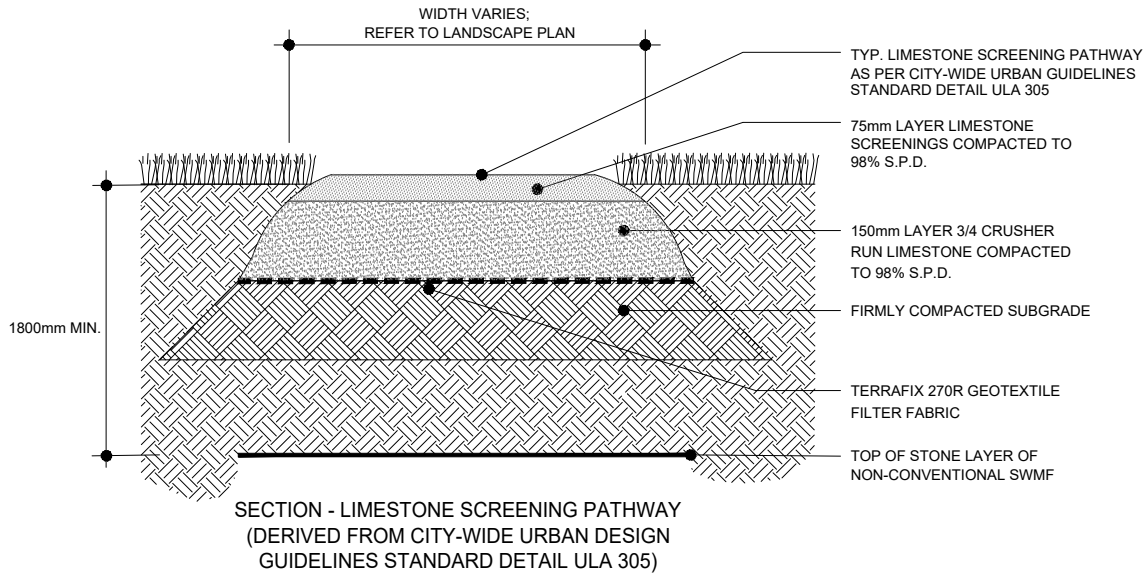

SECTION - LIMESTONE SCREENING PATHWAY  
(DERIVED FROM CITY-WIDE URBAN DESIGN  
GUIDELINES STANDARD DETAIL ULA 305)

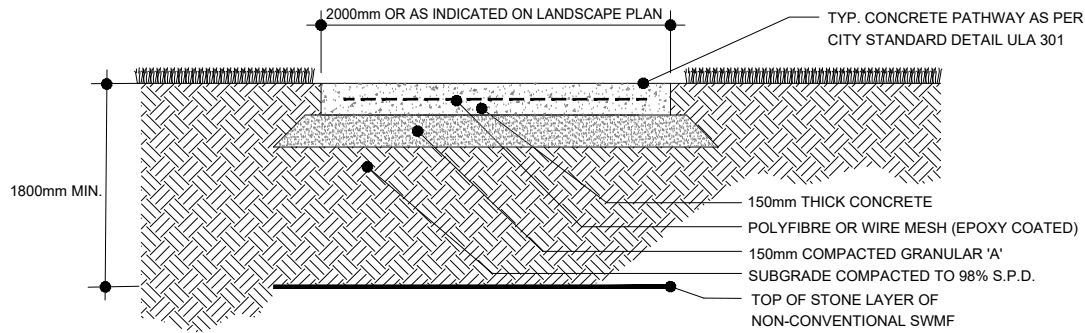

SECTION - CONCRETE PAVING PATHWAY  
(DERIVED FROM CITY-WIDE URBAN DESIGN  
GUIDELINES STANDARD DETAIL ULA 301)

**mm** DIMENSIONS IN MILLIMETRES  
EXCEPT AS NOTED

4.		
3.		
2.		
1.		
REVISIONS		DATE



CITY OF VAUGHAN ENGINEERING STANDARD

PATHWAY (TYP.)  
ABOVE A NON-CONVENTIONAL SWMF

NOT TO SCALE

DESIGNED: \_\_\_\_\_

STD. DWG.

REVISION: \_\_\_\_\_

DATE: JAN. 2025

S - 110

**NOTES:**

1. ALL DIMENSIONS ARE IN MILLIMETERS.
2. THIS TYPICAL DETAIL IS PROVIDED FOR DESIGN DIRECTION AND IS FOR REFERENCE ONLY. DETAIL MUST BE CERTIFIED BY A PROFESSIONAL ENGINEER IF INCLUDED AS PART OF THE SITE PLAN APPLICATION OR DRAFT PLAN OF SUBDIVISION, AS APPLICABLE.
3. THIS TYPICAL DETAIL IS INTENDED TO DISPLAY DETAILS WITH RESPECT TO PATHWAYS ABOVE NON-CONVENTIONAL SWMF. REFER TO CITY-WIDE URBAN DESIGN GUIDELINES STANDARD DETAIL ULA 301 AND 305 FOR PAVING DETAILS

Acad File: C:\Users\vaughan\OneDrive - City of Vaughan\Desktop - Standard\0405-111 - Pathway (Typ.) - Above a Non-conventional SWMF - A - Rev.dwg

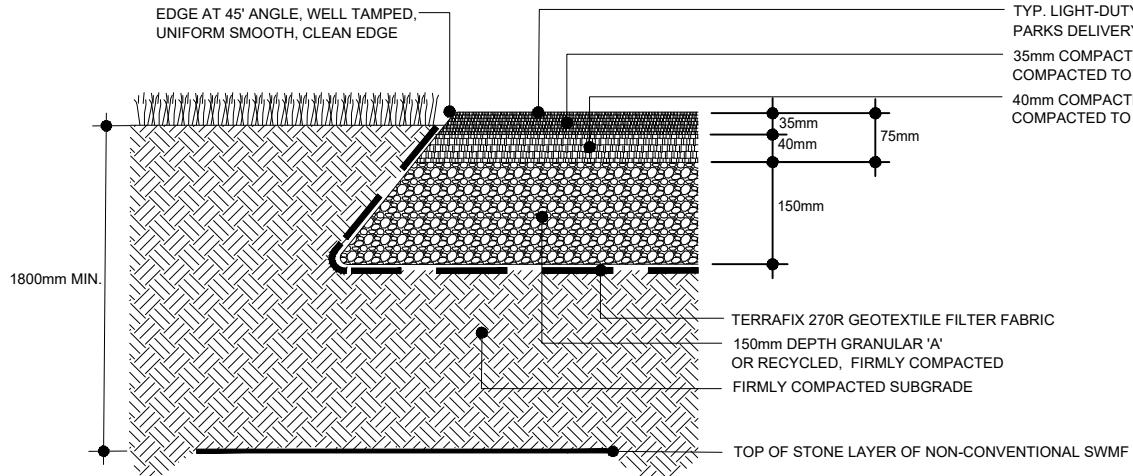

SECTION - LIGHT-DUTY ASPHALT PAVING  
(DERIVED FROM PARKS DELIVERY STANDARD DETAIL MLA 208)

TYP. LIGHT-DUTY ASPHALT PAVING AS PER  
PARKS DELIVERY STANDARD DETAIL MLA-208  
35mm COMPACTED DEPTH OR HL3A ASPHALT  
COMPACTED TO 98% S.P.D.  
40mm COMPACTED DEPTH HL-8 ASPHALT  
COMPACTED TO 98% S.P.D.

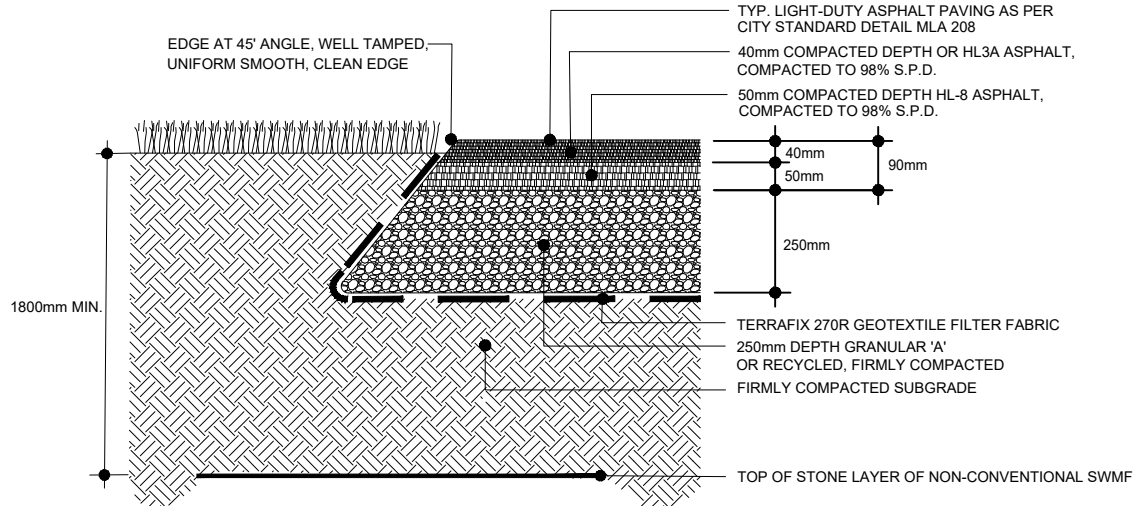

SECTION - HEAVY-DUTY ASPHALT PAVING  
(DERIVED FROM PARKS DELIVERY STANDARD DETAIL MLA 209)

TYP. LIGHT-DUTY ASPHALT PAVING AS PER  
CITY STANDARD DETAIL MLA 208  
40mm COMPACTED DEPTH OR HL3A ASPHALT,  
COMPACTED TO 98% S.P.D.  
50mm COMPACTED DEPTH HL-8 ASPHALT,  
COMPACTED TO 98% S.P.D.

**mm** DIMENSIONS IN MILLIMETRES  
EXCEPT AS NOTED

4.		
3.		
2.		
1.		
REVISIONS		DATE



CITY OF VAUGHAN ENGINEERING STANDARD  
ASPHALT PATHWAYS (TYP.)  
ABOVE A NON-CONVENTIONAL SWMF  
LOCATED WITHIN PARK

**NOTES:**

- ALL DIMENSIONS ARE IN MILLIMETERS.
- THIS TYPICAL DETAIL IS PROVIDED FOR DESIGN DIRECTION AND IS FOR REFERENCE ONLY. DETAIL MUST BE CERTIFIED BY A PROFESSIONAL ENGINEER IF INCLUDED AS PART OF THE SITE PLAN APPLICATION OR DRAFT PLAN OF SUBDIVISION, AS APPLICABLE.
- THIS TYPICAL DETAIL IS INTENDED TO DISPLAY DETAILS WITH RESPECT TO PATHWAYS ABOVE NON-CONVENTIONAL SWMF LOCATED WITHIN PARK. REFER TO PARKS DELIVERY STANDARD DETAILS MLA 208 AND 209 FOR PAVING DETAILS.

NOT TO SCALE      DESIGNED: \_\_\_\_\_

REVISION: \_\_\_\_\_      DATE: JAN. 2025

STD. DWG.

**S - 111**

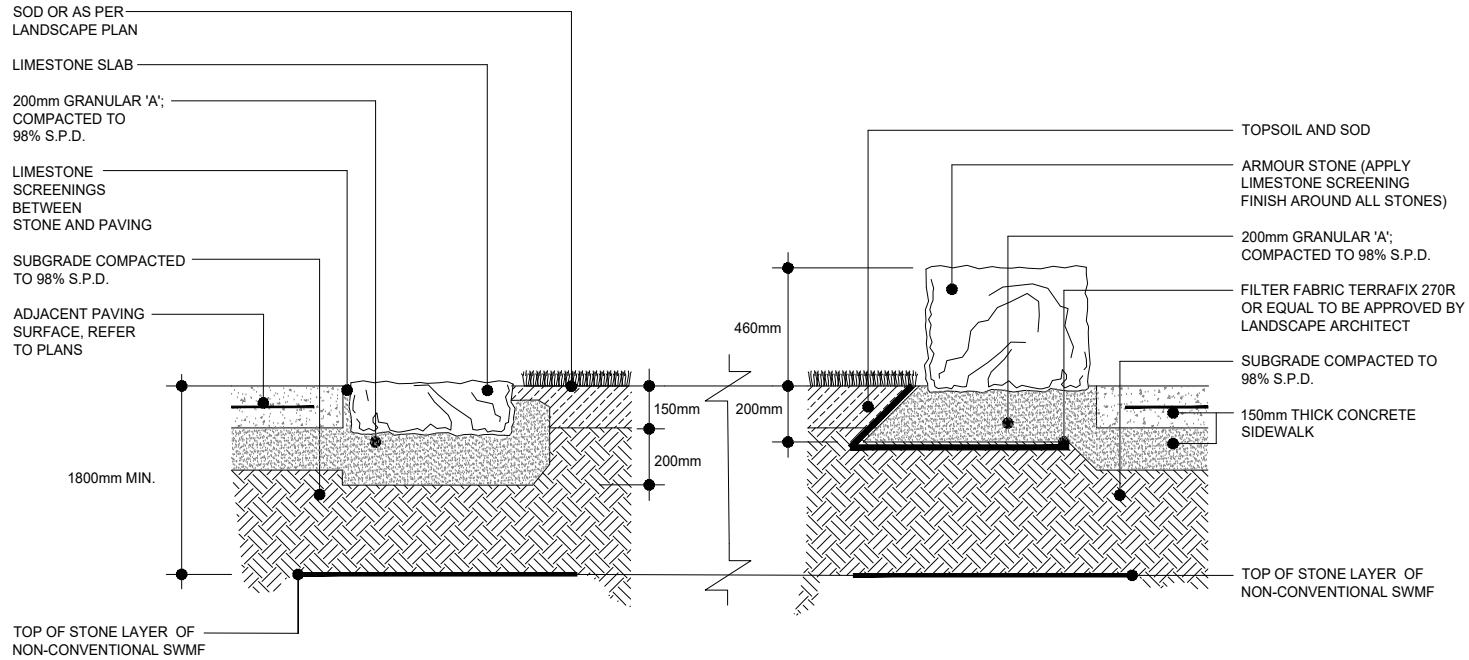

**SECTION - STEPPING STONE  
ADJACENT WALKWAY**  
(DERIVED FROM CITY-WIDE URBAN DESIGN  
GUIDELINES STANDARD DETAIL ULA 311)

**SECTION - ARMOUR STONE WITH  
P-I-P CONCRETE SIDEWALK**  
(DERIVED FROM CITY-WIDE URBAN DESIGN  
GUIDELINES STANDARD DETAIL ULA 309)

**mm** DIMENSIONS IN MILLIMETRES  
EXCEPT AS NOTED

4.		
3.		
2.		
1.		
REVISIONS		DATE



CITY OF VAUGHAN ENGINEERING STANDARD

**ARMOUR STONE (TYP.) DETAIL  
ABOVE A NON-CONVENTIONAL SWMF**

**NOTES:**

1. ALL STONES TO BE APPROVED BY LANDSCAPE ARCHITECT PRIOR TO INSTALLATION.
2. ALL QUARRY STONE TO HAVE SPLIT OR NATURALLY WEATHERED FACES; NO EXPOSED DRILL MARKINGS.
3. THIS TYPICAL DETAIL IS PROVIDED FOR DESIGN DIRECTION AND IS FOR REFERENCE ONLY. DETAIL MUST BE CERTIFIED BY A PROFESSIONAL ENGINEER IF INCLUDED AS PART OF THE SITE PLAN APPLICATION OR DRAFT PLAN OF SUBDIVISION, AS APPLICABLE.

NOT TO SCALE      DESIGNED: \_\_\_\_\_

REVISION: \_\_\_\_\_      DATE: \_\_\_\_\_ JAN. 2025 \_\_\_\_\_

STD. DWG.

**S - 112**

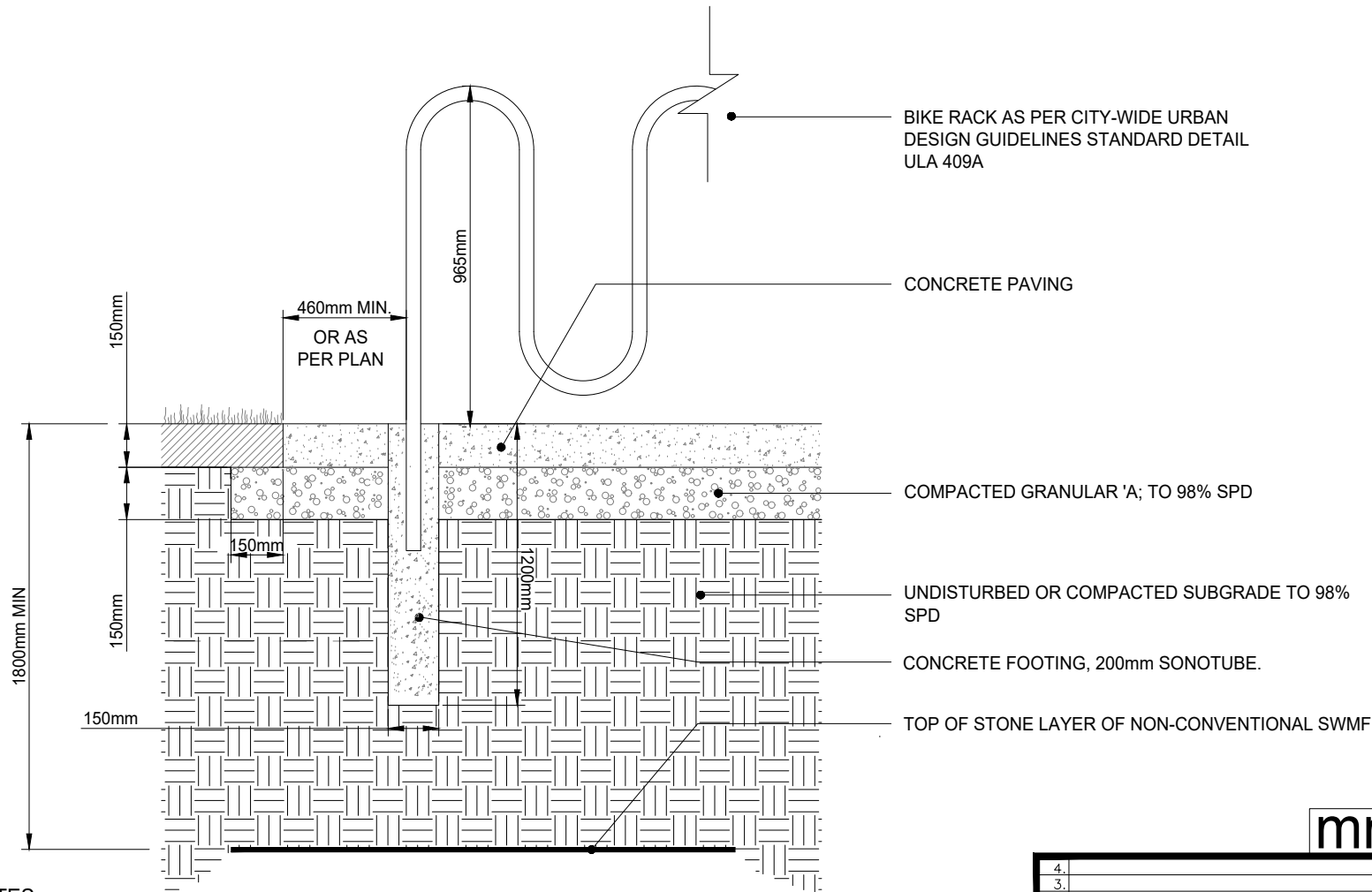

**mm** DIMENSIONS IN MILLIMETRES EXCEPT AS NOTED

**NOTES:**

1. ALL DIMENSIONS ARE IN MILLIMETERS.
2. REFER TO LAYOUT PLAN FOR PLACEMENT/LOCATION OF BIKE RACK.
3. THIS TYPICAL DETAIL IS PROVIDED FOR DESIGN DIRECTION AND IS FOR REFERENCE ONLY. DETAIL MUST BE CERTIFIED BY A PROFESSIONAL ENGINEER IF INCLUDED AS PART OF THE SITE PLAN APPLICATION OR DRAFT PLAN OF SUBDIVISION, AS APPLICABLE.
4. THIS TYPICAL DETAIL IS INTENDED TO DISPLAY DETAILS WITH RESPECT TO BIKE RACKS ABOVE NON-CONVENTIONAL SWMF. REFER TO CITY-WIDE URBAN DESIGN GUIDELINES STANDARD DETAIL ULA 409A FOR BIKE RACK DETAILS.

4.		
3.		
2.		
1.		
REVISIONS		DATE



CITY OF VAUGHAN ENGINEERING STANDARD

**BIKE RACK DETAIL (TYP.)  
ABOVE A NON-CONVENTIONAL SWMF**

NOT TO SCALE      DESIGNED: \_\_\_\_\_

REVISION: \_\_\_\_\_      DATE: \_\_\_\_\_ JAN. 2025

STD. DWG.

**S - 113**

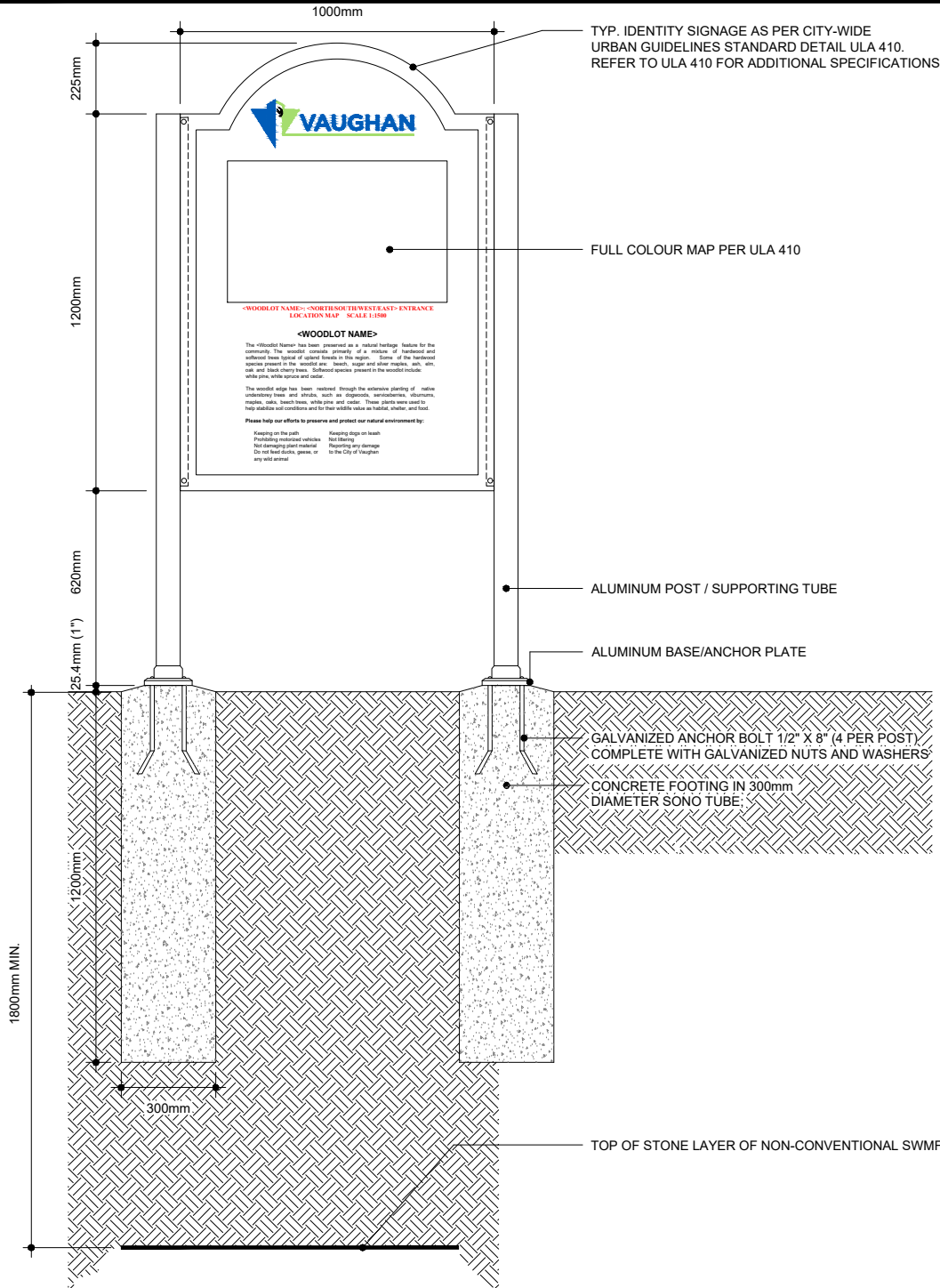

TYP. IDENTITY SIGNAGE AS PER CITY-WIDE URBAN GUIDELINES STANDARD DETAIL ULA 410. REFER TO ULA 410 FOR ADDITIONAL SPECIFICATIONS

FULL COLOUR MAP PER ULA 410

ALUMINUM POST / SUPPORTING TUBE

ALUMINUM BASE/ANCHOR PLATE

GALVANIZED ANCHOR BOLT 1/2" X 8" (4 PER POST) COMPLETE WITH GALVANIZED NUTS AND WASHERS

CONCRETE FOOTING IN 300mm DIAMETER SONO TUBE

TOP OF STONE LAYER OF NON-CONVENTIONAL SWMF

**NOTES:**

1. THIS TYPICAL DETAIL IS INTENDED TO DISPLAY DETAILS WITH RESPECT TO IDENTIFY SIGNAGE ABOVE NON-CONVENTIONAL SWMF. REFER TO CITY-WIDE URBAN DESIGN GUIDELINES STANDARD DETAIL ULA 410 FOR FURTHER DETAIL.
2. THIS TYPICAL DETAIL IS PROVIDED FOR DESIGN DIRECTION AND IS FOR REFERENCE ONLY. DETAIL MUST BE CERTIFIED BY A PROFESSIONAL ENGINEER IF INCLUDED AS PART OF THE SITE PLAN APPLICATION OR DRAFT PALN OF SUBDIVISION, AS APPLICABLE.

**mm** DIMENSIONS IN MILLIMETRES EXCEPT AS NOTED

4.		
3.		
2.		
1.		
REVISIONS		DATE



CITY OF VAUGHAN ENGINEERING STANDARD

**IDENTITY SIGNAGE (TYP.)  
ABOVE A NON-CONVENTIONAL SWMF**

NOT TO SCALE      DESIGNED: \_\_\_\_\_  
REVISION: \_\_\_\_\_      DATE: \_\_\_\_\_ JAN. 2025

STD. DWG.  
**S - 114**

REFER TO CITY-WIDE URBAN DESIGN GUIDELINES STANDARD DETAIL ULA 412 AND 413 FOR DETAILS ON GATES

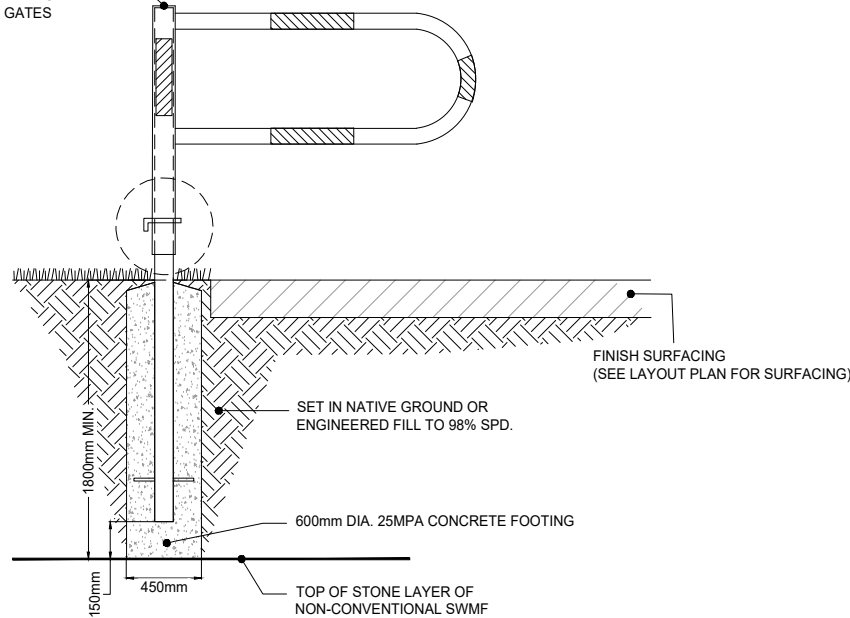

**mm** DIMENSIONS IN MILLIMETRES EXCEPT AS NOTED

**NOTES:**

1. ALL MEASUREMENTS ARE IN MILLIMETRES UNLESS STATED OTHERWISE.
2. THIS TYPICAL DETAIL IS PROVIDED FOR DESIGN DIRECTION AND IS FOR REFERENCE ONLY. DETAIL MUST BE CERTIFIED BY A PROFESSIONAL ENGINEER IF INCLUDED AS PART OF THE SITE PLAN APPLICATION OR DRAFT PLAN OF SUBDIVISION, AS APPLICABLE.
3. THIS TYPICAL DETAIL IS INTENDED TO DISPLAY DETAILS WITH RESPECT TO GATES ABOVE NON-CONVENTIONAL SWMF. REFER TO CITY-WIDE URBAN DESIGN GUIDELINES STANDARD DETAIL ULA 412 AND 413 FOR GATE DETAILS
4. LOCATION TO BE FIELD STAKED AND APPROVED BY LANDSCAPE ARCHITECT PRIOR TO INSTALLATION.
5. PROTECT EXISTING PATHWAYS AND WALKWAYS FROM DAMAGE. CONTRACTOR RESPONSIBLE TO RESTORE ALL DAMAGES AT NO ADDITIONAL COST TO THE CITY.

4.		
3.		
2.		
1.		
REVISIONS		DATE



CITY OF VAUGHAN ENGINEERING STANDARD

**GATE (TYP.)  
ABOVE A NON-CONVENTIONAL SWMF**

NOT TO SCALE

DESIGNED: \_\_\_\_\_

REVISION: \_\_\_\_\_

DATE: JAN. 2025

STD. DWG.

**S - 115**



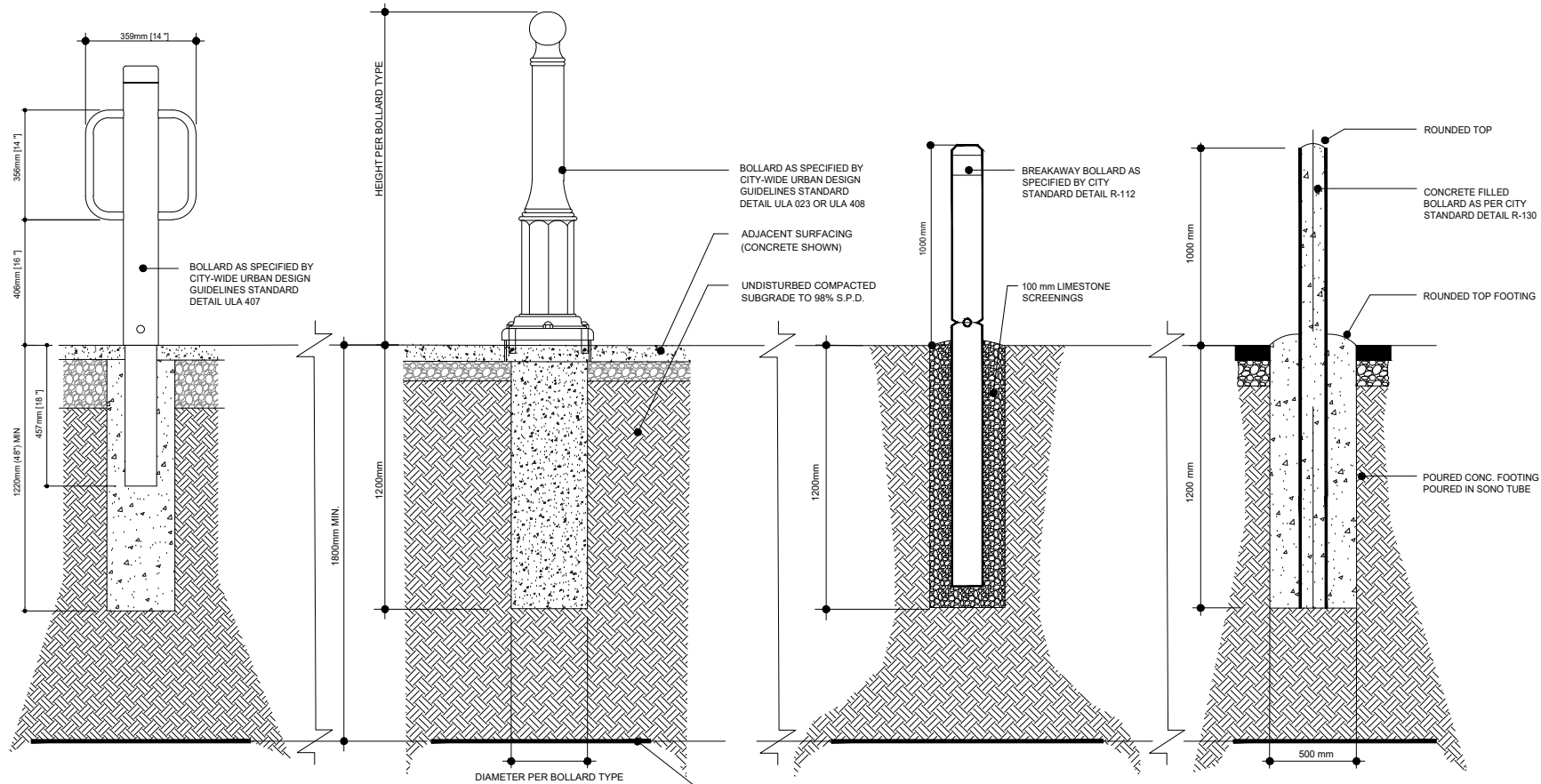

**mm** DIMENSIONS IN MILLIMETRES EXCEPT AS NOTED

4.		
3.		
2.		
1.		
REVISIONS		DATE



**CITY OF VAUGHAN ENGINEERING STANDARD**

**BOLLARD (TYP.)  
ABOVE A NON-CONVENTIONAL SWMF**

NOT TO SCALE      DESIGNED: \_\_\_\_\_  
 REVISION: \_\_\_\_\_      DATE: \_\_\_\_\_ JAN. 2025

STD. DWG.  
**S - 116**

**NOTES:**

1. THIS TYPICAL DETAIL IS PROVIDED FOR DESIGN DIRECTION AND IS FOR REFERENCE ONLY. DETAIL MUST BE CERTIFIED BY A PROFESSIONAL ENGINEER IF INCLUDED AS PART OF THE SITE PLAN APPLICATION OR DRAFT PLAN OF SUBDIVISION, AS APPLICABLE.
2. THIS TYPICAL DETAIL IS INTENDED TO DISPLAY DETAILS WITH RESPECT TO BOLLARDS ABOVE NON-CONVENTIONAL SWMF. REFER TO CITY-WIDE URBAN DESIGN GUIDELINES STANDARD DETAILS ULA-023, 407 AND 408 FOR BOLLARD DETAILS. REFER TO CITY STANDARD DETAIL R-112 FOR BREAKAWAY BOLLARD DETAILS. REFER TO CITY STANDARD DETAIL R-130 FOR CONCRETE BOLLARD DETAILS.

Acad File: C:\Users\vaughan\OneDrive - City of Vaughan\Documents - Engineering\Standards - Standard\ULAS-117 - Tree Planting (Typ.) Above a Non-conventional SWMF - Rev.dwg

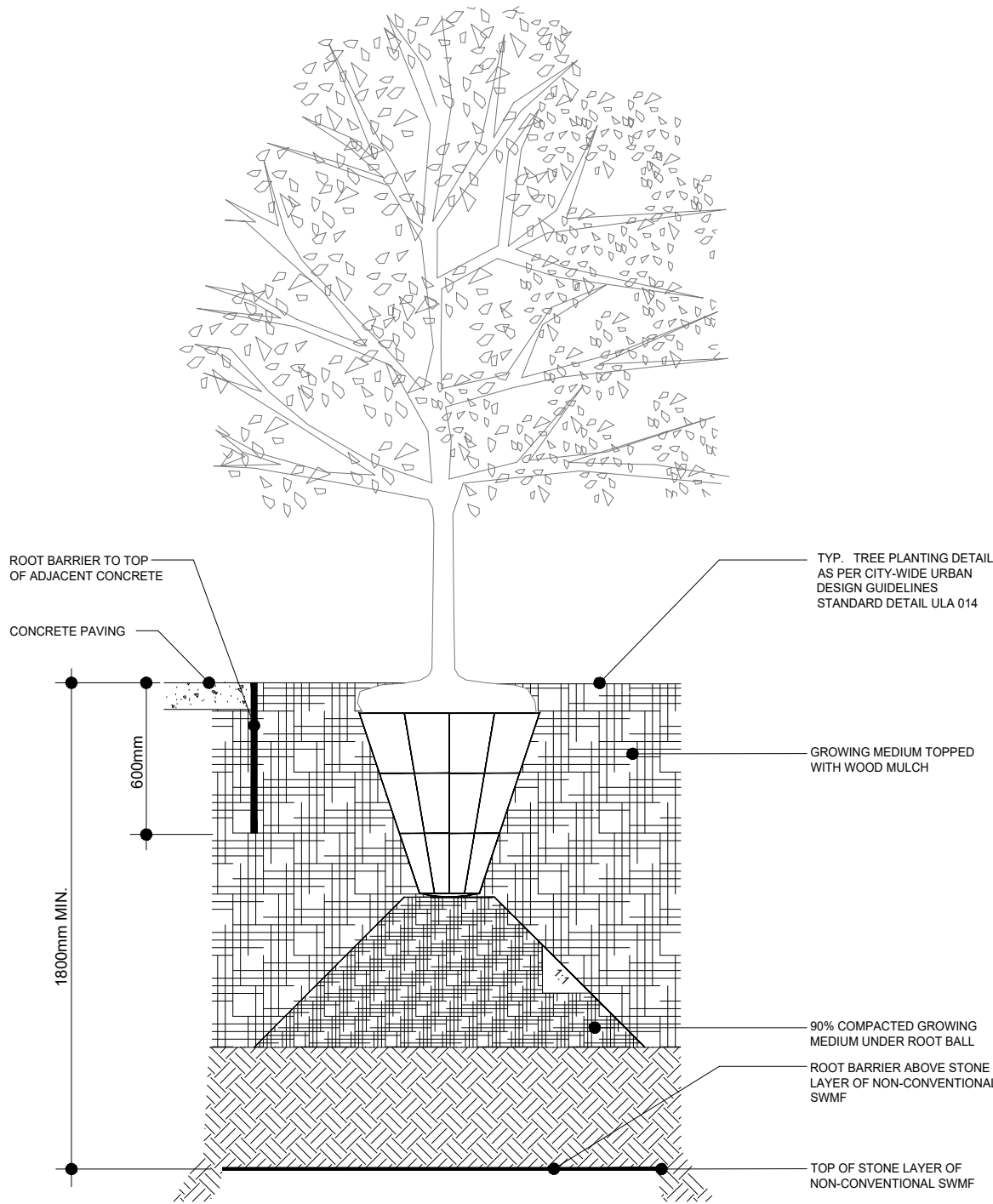

**NOTES:**

1. THIS TYPICAL DETAIL IS PROVIDED FOR DEIGN DIRECTION AND IS FOR REFERENCE ONLY. DETAIL MUST BE CERTIFIED BY A PROFESSIONAL ENGINEER IF INCLUDED AS PART OF THE SITE PLAN APPLICATION OR DRAFT PLAN OF SUBDIVISION, AS APPLICABLE.
2. THIS TYPICAL DETAIL IS INTENDED TO DISPLAY DETAILS WITH RESPECT TO TREE PLANTING ABOVE NON-CONVENTIONAL SWMF. REFER TO CITY-WIDE URBAN DESIGN GUIDELINES VOLUME 2 ULA 014 FOR TREE PLANTING DETAILS.

**mm** DIMENSIONS IN MILLIMETRES EXCEPT AS NOTED

4.		
3.		
2.		
1.		
REVISIONS		DATE



CITY OF VAUGHAN ENGINEERING STANDARD

**TREE PLANTING (TYP.)  
ABOVE A NON-CONVENTIONAL SWMF**

NOT TO SCALE      DESIGNED: \_\_\_\_\_

REVISION: \_\_\_\_\_      DATE: \_\_\_\_\_ JAN. 2025 \_\_\_\_\_

STD. DWG.

**S - 117**

TYPICAL SHRUB PLANTING DETAIL AS PER CITY-WIDE URBAN DESIGN GUIDELINES STANDARD DETAIL ULA 015

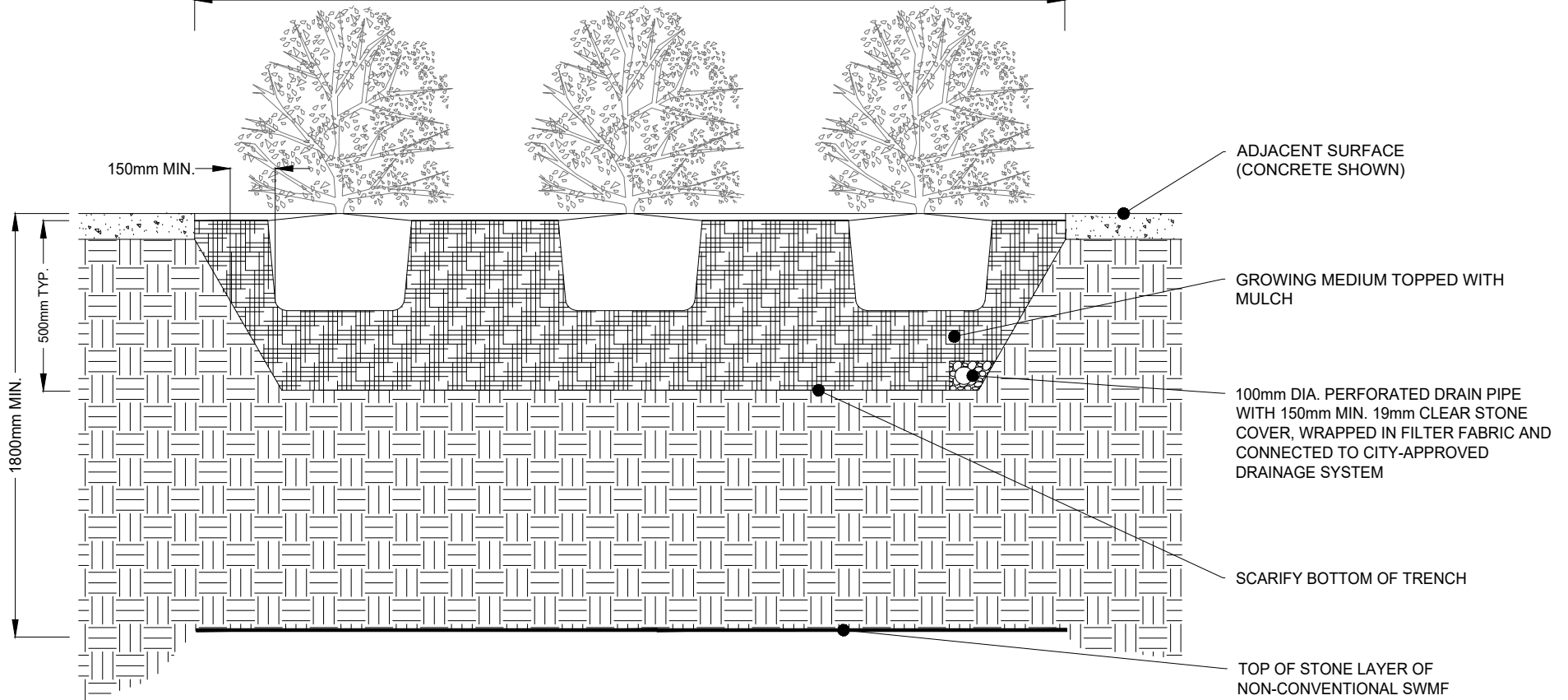

**mm** DIMENSIONS IN MILLIMETRES EXCEPT AS NOTED

4.		
3.		
2.		
1.		
REVISIONS		DATE



CITY OF VAUGHAN ENGINEERING STANDARD

SHRUB PLANTING (TYP.)  
ABOVE A NON-CONVENTIONAL SWMF

NOT TO SCALE

DESIGNED: \_\_\_\_\_

STD. DWG.

REVISION: \_\_\_\_\_

DATE: \_\_\_\_\_ JAN. 2025 \_\_\_\_\_

S - 118

NOTES:

1. THIS TYPICAL DETAIL IS PROVIDED FOR DESIGN DIRECTION AND IS FOR REFERENCE ONLY. DETAIL MUST BE CERTIFIED BY A PROFESSIONAL ENGINEER IF INCLUDED AS PART OF THE SITE PLAN APPLICATION OR DRAFT PLAN OF SUBDIVISION, AS APPLICABLE.
2. THIS TYPICAL DETAIL IS INTENDED TO DISPLAY DETAILS WITH RESPECT TO SHRUB PLANTING ABOVE NON-CONVENTIONAL SWMF. REFER TO CITY-WIDE URBAN DESIGN GUIDELINES STANDARD DETAIL ULA 015 FOR SHRUB PLANTING DETAILS.

Acad File: C:\Users\vaughan\OneDrive - City of Vaughan\Desktop\2025\Draw - Storm Connection\Drawings from a Non-conventional SWMF - Rev.dwg

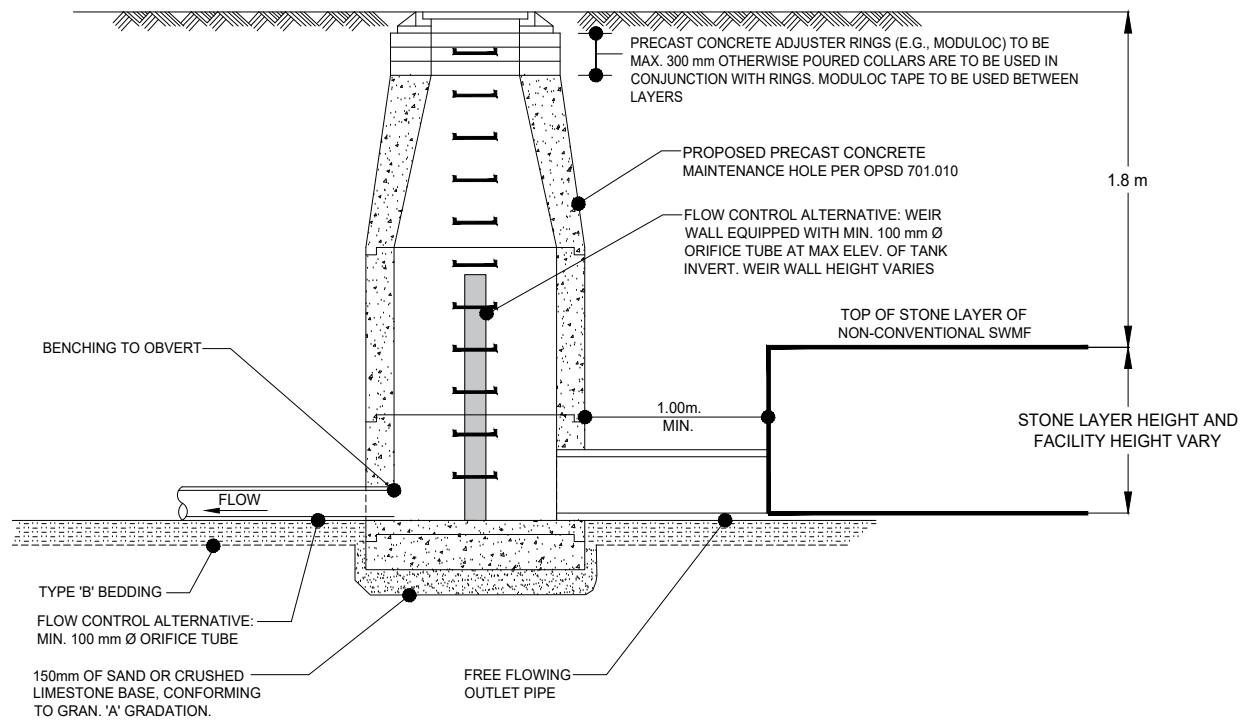

**mm** DIMENSIONS IN MILLIMETRES EXCEPT AS NOTED

4.		
3.		
2.		
1.		
REVISIONS		DATE



**CITY OF VAUGHAN ENGINEERING STANDARD**  
**EXAMPLE STORM CONNECTION DOWNSTREAM**  
**FROM A NON-CONVENTIONAL SWMF**

**NOTES:**

1. THIS TYPICAL DETAIL IS PROVIDED FOR DESIGN DIRECTION AND IS FOR REFERENCE ONLY. DETAIL MUST BE CERTIFIED BY A PROFESSIONAL ENGINEER IF INCLUDED AS PART OF THE SITE PLAN APPLICATION OR DRAFT PLAN OF SUBDIVISION, AS APPLICABLE.
2. THIS TYPICAL DETAIL IS INTENDED TO DISPLAY DETAILS WITH RESPECT TO THE NON-CONVENTIONAL SWMF, DOWNSTREAM MANHOLE CONNECTIONS.
3. THIS DETAIL HAS BEEN DERIVED FROM CITY STANDARD DETAIL C-104.

NOT TO SCALE      DESIGNED: \_\_\_\_\_  
 REVISION: \_\_\_\_\_      DATE: JAN. 2025

STD. DWG.  
**S - 119**

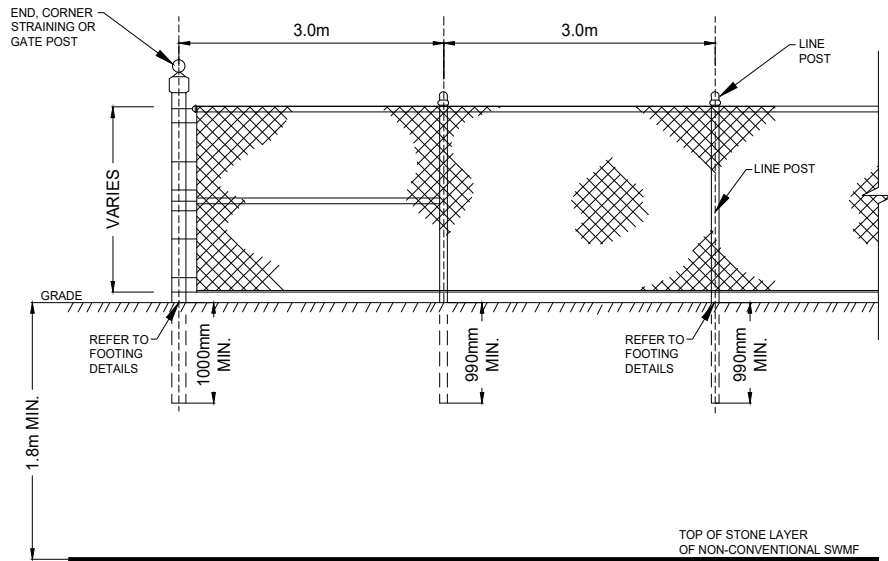

FENCE DETAILS

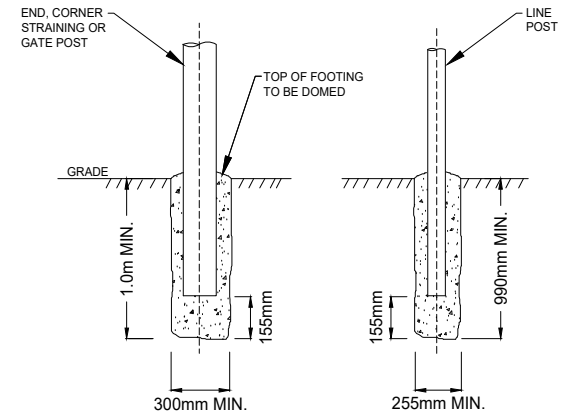

FOOTING DETAILS

**mm** DIMENSIONS IN MILLIMETRES  
EXCEPT AS NOTED

**NOTES:**

1. THIS TYPICAL DETAIL IS PROVIDED FOR DESIGN DIRECTION AND IS FOR REFERENCE ONLY. DETAIL MUST BE CERTIFIED BY A PROFESSIONAL ENGINEER IF INCLUDED AS PART OF THE SITE PLAN APPLICATION OR DRAFT PLAN OF SUBDIVISION, AS APPLICABLE.
2. THIS TYPICAL DETAIL IS INTENDED TO DISPLAY DETAILS WITH RESPECT TO CHAIN LINK FENCES ABOVE NON-CONVENTIONAL SWMF. REFER TO CITY STANDARD DETAIL FRW-101 FOR ADDITIONAL SPECIFICATIONS ON CHAIN LINK FENCES.

4.		
3.		
2.		
1.		
REVISIONS		DATE



CITY OF VAUGHAN ENGINEERING STANDARD

**CHAIN LINK SECURITY FENCE (TYP.)  
ABOVE A NON-CONVENTIONAL SWMF**

NOT TO SCALE      DESIGNED: \_\_\_\_\_

REVISION: \_\_\_\_\_      DATE: \_\_\_\_\_ JAN. 2025

STD. DWG.

**S - 120**



Root File: C:\Users\vaughan\OneDrive - City of Vaughan\Documents - General\Design\City Standards - General\Design\City Standards - 2025\Draw - Standards\ULAS-122 - Asphalt Paving (Heavy Duty) (Typ) Above a Non-conventional SWMF - New.dwg

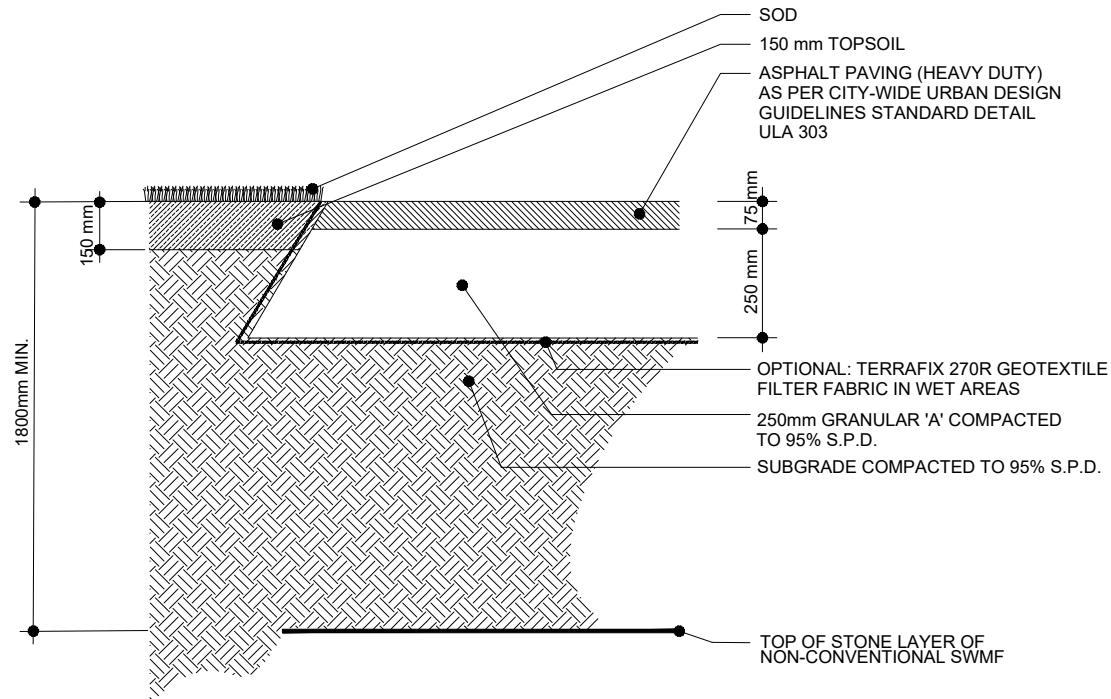

**mm** DIMENSIONS IN MILLIMETRES  
EXCEPT AS NOTED

4.		
3.		
2.		
1.		
REVISIONS		DATE



**CITY OF VAUGHAN ENGINEERING STANDARD**  
**ASPHALT PAVING - HEAVY DUTY (TYP.)**  
**ABOVE A NON-CONVENTIONAL SWMF**  
**LOCATED WITHIN ROW**

**NOTES:**

1. ALL DIMENSIONS ARE IN MILLIMETERS.
2. THIS TYPICAL DETAIL IS PROVIDED FOR DESIGN DIRECTION AND IS FOR REFERENCE ONLY. DETAIL MUST BE CERTIFIED BY A PROFESSIONAL ENGINEER IF INCLUDED AS PART OF THE SITE PLAN APPLICATION OR DRAFT PLAN OF SUBDIVISION, AS APPLICABLE.
3. THIS TYPICAL DETAIL IS INTENDED TO DISPLAY DETAILS WITH RESPECT TO PATHWAYS ABOVE NON-CONVENTIONAL SWMF LOCATED WITHIN ROW. REFER TO CITY-WIDE URBAN DESIGN GUIDELINES STANDARD DETAIL ULA 303 FOR HEAVY-DUTY PAVING DETAILS.

NOT TO SCALE      DESIGNED: \_\_\_\_\_

REVISION: \_\_\_\_\_      DATE: JAN. 2025

STD. DWG.

**S - 122**

Road File: C:\Users\vaughan\OneDrive - City of Vaughan\Documents - Design\Design\City Standards - Standards\LA05-123 - Asphalt Paving (Light Duty) (Typ.) Above a Non-conventional SWMF - New.dwg

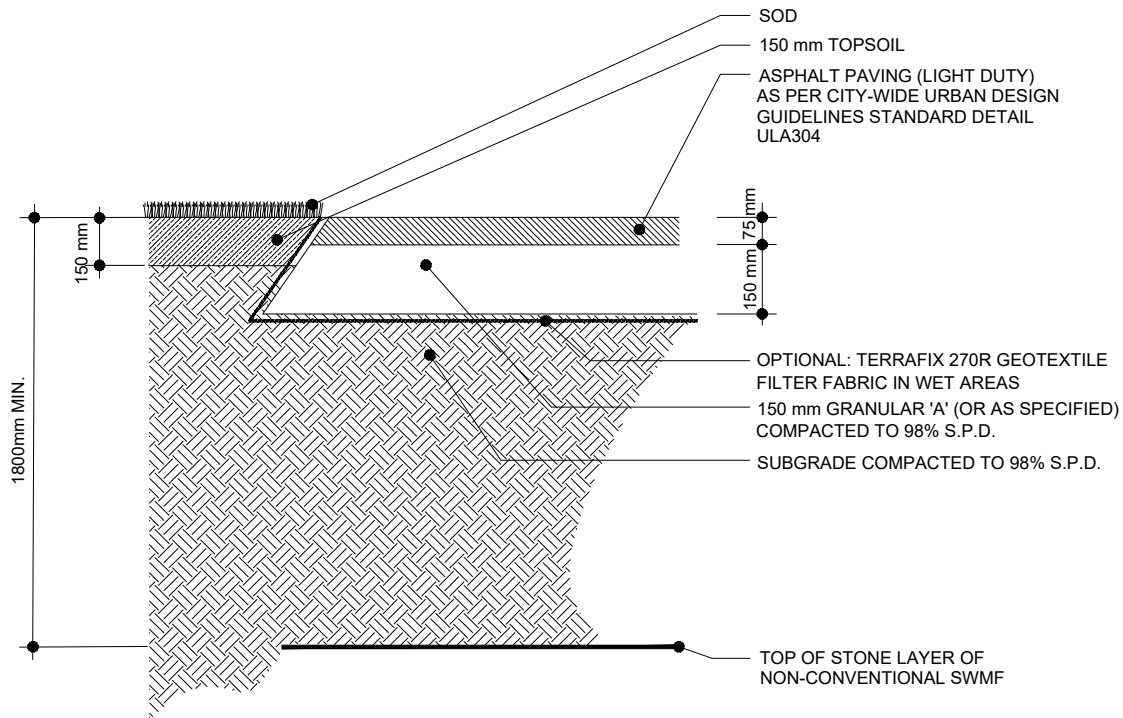

**mm** DIMENSIONS IN MILLIMETRES  
EXCEPT AS NOTED

4.		
3.		
2.		
1.		
REVISIONS		DATE



**CITY OF VAUGHAN ENGINEERING STANDARD**  
**ASPHALT PAVING - LIGHT DUTY (TYP.)**  
**ABOVE A NON-CONVENTIONAL SWMF**  
**LOCATED WITHIN ROW**

**NOTES:**

1. ALL DIMENSIONS ARE IN MILLIMETERS.
2. THIS TYPICAL DETAIL IS PROVIDED FOR DESIGN DIRECTION AND IS FOR REFERENCE ONLY. DETAIL MUST BE CERTIFIED BY A PROFESSIONAL ENGINEER IF INCLUDED AS PART OF THE SITE PLAN APPLICATION OR DRAFT PLAN OF SUBDIVISION, AS APPLICABLE.
3. THIS TYPICAL DETAIL IS INTENDED TO DISPLAY DETAILS WITH RESPECT TO PATHWAYS ABOVE NON-CONVENTIONAL SWMF LOCATED WITHIN ROW. REFER TO CITY-WIDE URBAN DESIGN GUIDELINES STANDARD DETAIL ULA 304 FOR LIGHT-DUTY PAVING DETAILS.

NOT TO SCALE      DESIGNED: \_\_\_\_\_

REVISION: \_\_\_\_\_      DATE: JAN. 2025

STD. DWG.

**S - 123**



Acad File: C:\Users\vaughan\OneDrive - City of Vaughan\Documents\Standards - General\Design Criteria\2025\Draw - Standards\DCS-124 - Decorative Pole (Typ) Above a Non-conventional SWMF - Rev.dwg

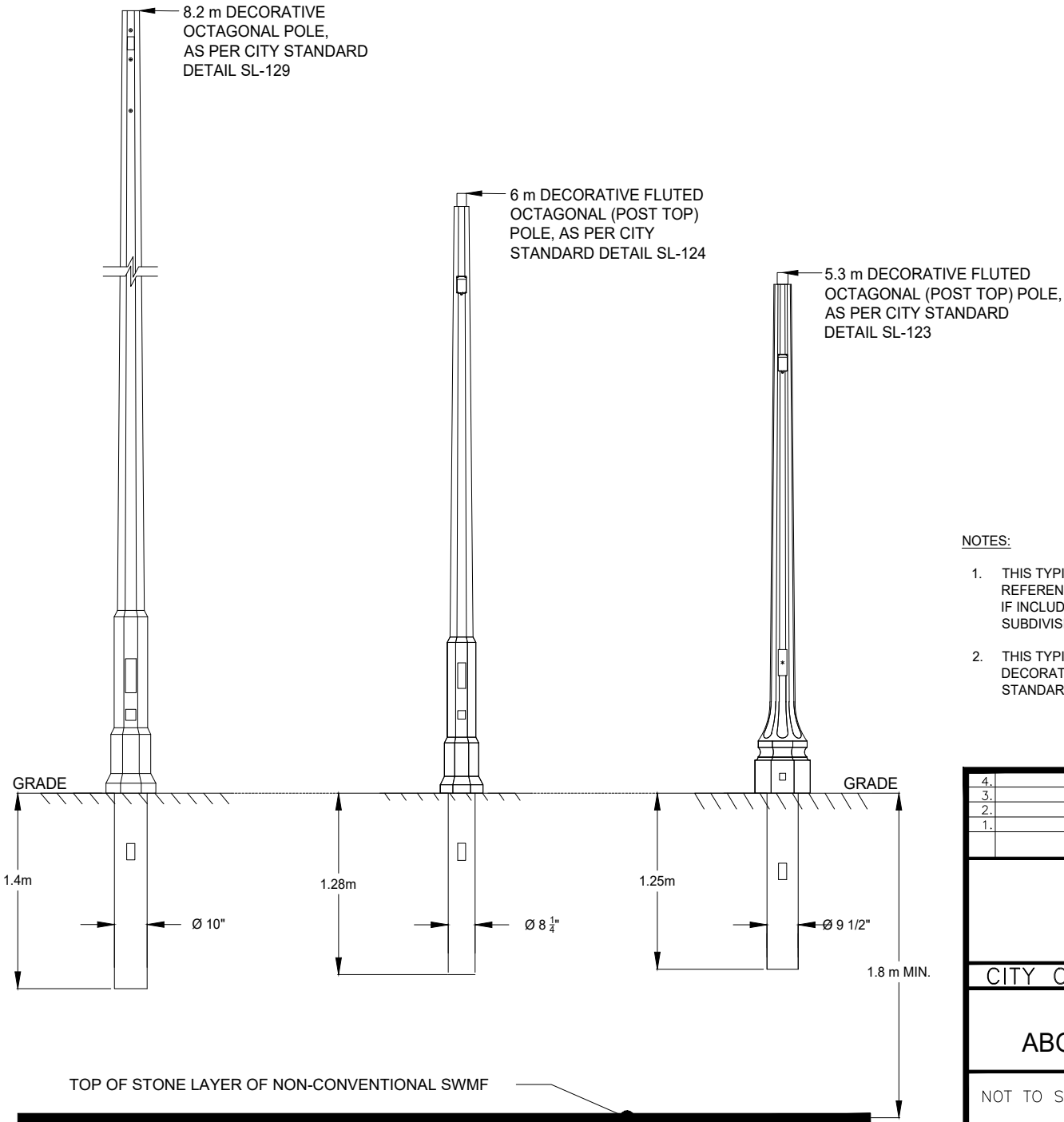

**NOTES:**

1. THIS TYPICAL DETAIL IS PROVIDED FOR DESIGN DIRECTION AND IS FOR REFERENCE ONLY. DETAIL MUST BE CERTIFIED BY A PROFESSIONAL ENGINEER IF INCLUDED AS PART OF THE SITE PLAN APPLICATION OR DRAFT PLAN OF SUBDIVISION, AS APPLICABLE.
2. THIS TYPICAL DETAIL IS INTENDED TO DISPLAY DETAILS WITH RESPECT TO DECORATIVE POLES ABOVE NON-CONVENTIONAL SWMF. REFER TO CITY STANDARD DETAILS: SL-123, SL-124 AND SL-129 FOR POLE DETAILS.

**mm** DIMENSIONS IN MILLIMETRES EXCEPT AS NOTED

4.		
3.		
2.		
1.		
REVISIONS		DATE



CITY OF VAUGHAN ENGINEERING STANDARD

**DECORATIVE POLE (TYP.)  
ABOVE A NON-CONVENTIONAL SWMF**

NOT TO SCALE      DESIGNED: \_\_\_\_\_  
 REVISION: \_\_\_\_\_      DATE: JAN. 2025

STD. DWG.  
**S - 124**

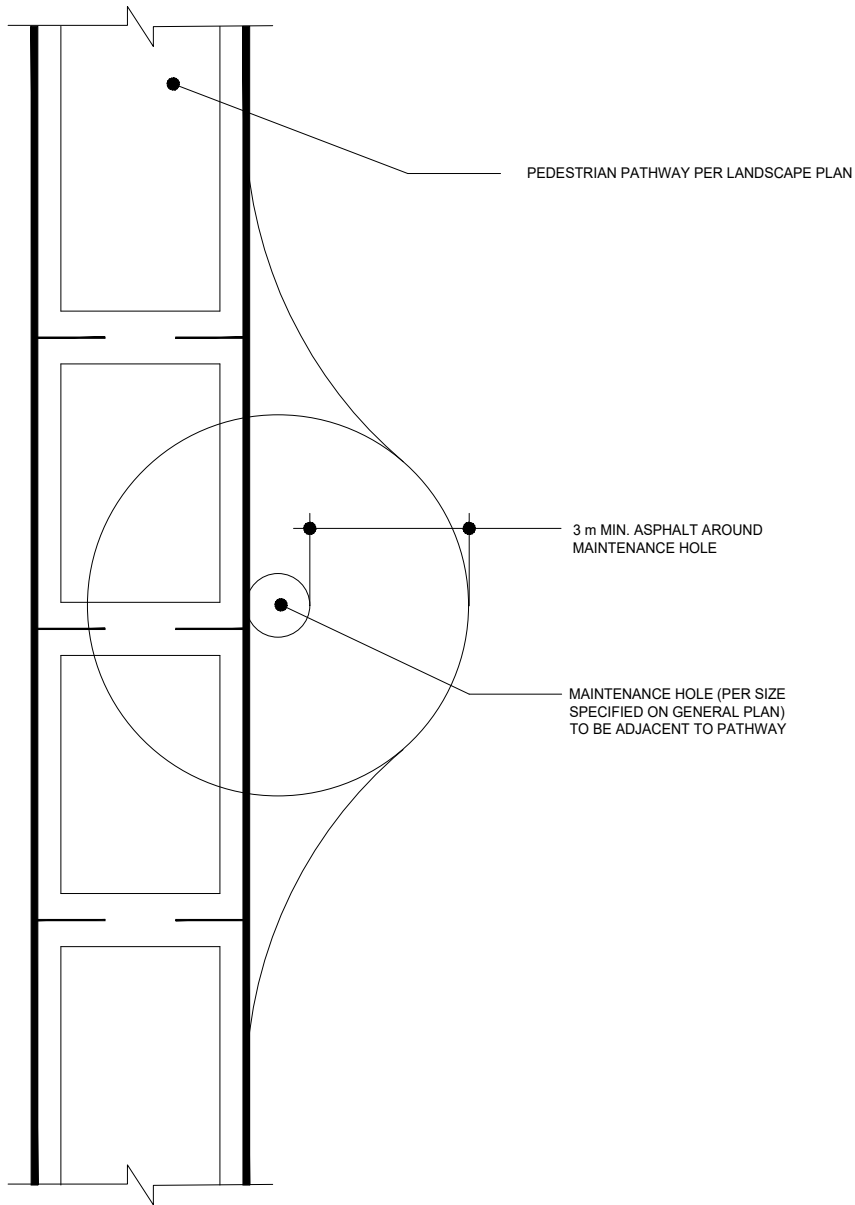

**mm** DIMENSIONS IN MILLIMETRES  
EXCEPT AS NOTED

4.		
3.		
2.		
1.		
REVISIONS		DATE



**CITY OF VAUGHAN ENGINEERING STANDARD**

**MAINTENANCE HOLE BUMP OUT FROM  
PEDESTRIAN PATH FOR NON-CONVENTIONAL SWMF**

NOT TO SCALE      DESIGNED: \_\_\_\_\_  
REVISION: \_\_\_\_\_      DATE: \_\_\_\_\_ JAN. 2025

STD. DWG.  
**S - 125**

**NOTES:**

1. PATHWAY TYPE SHALL BE SPECIFIED IN LANDSCAPE PLAN
2. THIS TYPICAL DETAIL IS PROVIDED FOR DESIGN DIRECTION AND IS FOR REFERENCE ONLY. DETAIL MUST BE CERTIFIED BY A PROFESSIONAL ENGINEER IF INCLUDED AS PART OF THE SITE PLAN APPLICATION OR DRAFT PLAN OF SUBDIVISION, AS APPLICABLE.
3. THIS TYPICAL DETAIL IS INTENDED TO DISPLAY DETAILS WITH RESPECT TO MAINTENANCE HOLES FOR NON-CONVENTIONAL SWMF. REFER TO RELEVANT CITY STANDARDS FOR PAVING/PATHWAY DETAILS.

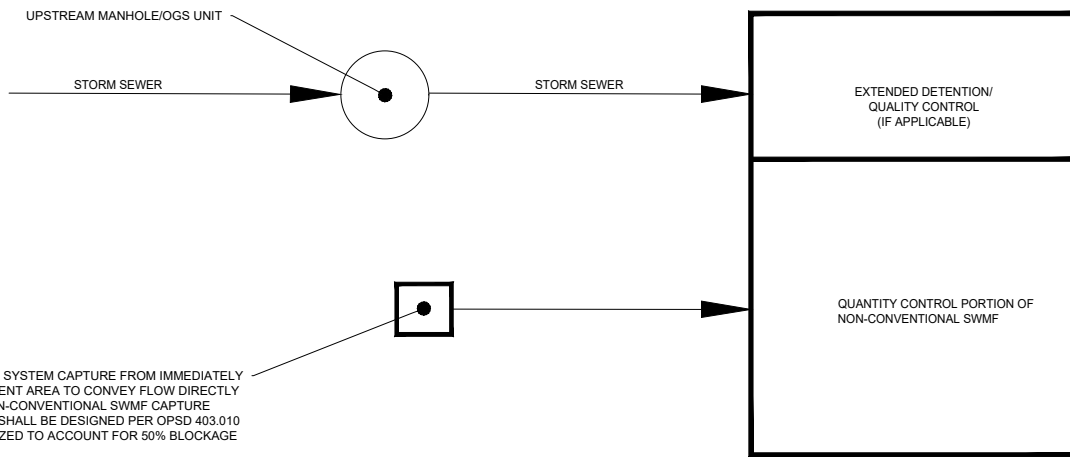

PLAN VIEW - NON-CONVENTIONAL SWMF  
INLET SAMPLE CONFIGURATION

**mm** DIMENSIONS IN MILLIMETRES  
EXCEPT AS NOTED

4.		
3.		
2.		
1.		
REVISIONS		DATE



CITY OF VAUGHAN ENGINEERING STANDARD  
CONCEPTUAL STORM SEWER CONNECTION  
TO NON-CONVENTIONAL SWMF DETAIL

NOTES:

1. DETAIL REPRESENTS MAXIMUM DEPTH TO NON-CONVENTIONAL SWMF'S WITHIN PROPOSED ROW'S AND MAXIMUM INSPECTION/MAINTENANCE PORT SPACING.
2. THIS TYPICAL DETAIL IS PROVIDED FOR DESIGN DIRECTION AND IS FOR REFERENCE ONLY. DETAIL MUST BE CERTIFIED BY A PROFESSIONAL ENGINEER IF INCLUDED AS PART OF THE SITE PLAN APPLICATION OR DRAFT PLAN OF SUBDIVISION, AS APPLICABLE.

NOT TO SCALE      DESIGNED: \_\_\_\_\_

REVISION: \_\_\_\_\_      DATE: \_\_\_\_\_ JAN. 2025 \_\_\_\_\_

STD. DWG.

**S - 126**



FILE: C:\Infrastructure Delivery\Infrastructure Programming\PMO\City Standards\Design Criteria: 2020-21\City Standards Update Folder\CoStandardDrawings\_CAD\_2021\W-101 - Single Valve in Chamber.dwg

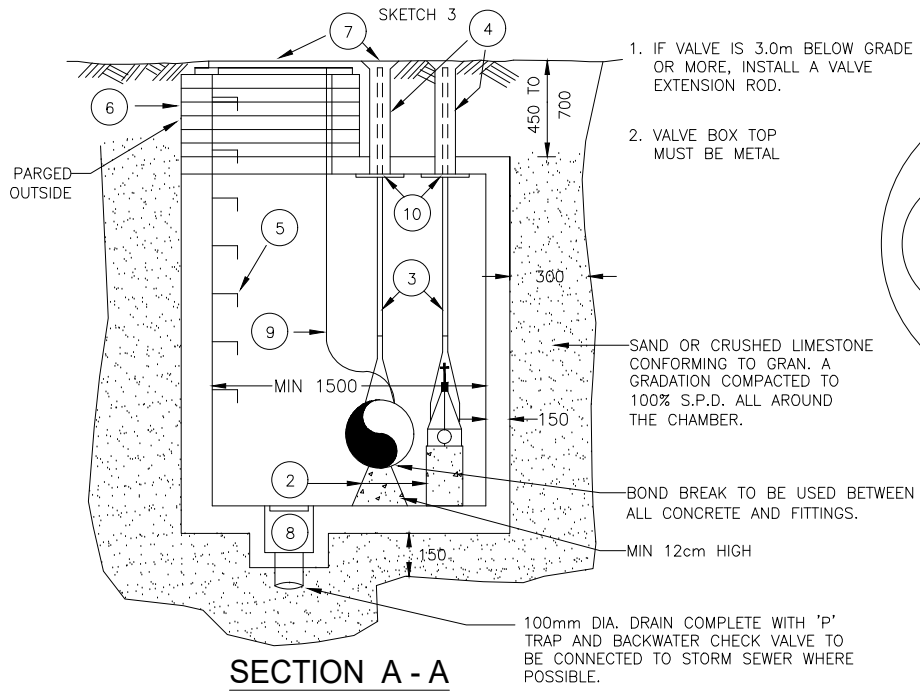

**SECTION A - A**

1. IF VALVE IS 3.0m BELOW GRADE OR MORE, INSTALL A VALVE EXTENSION ROD.
2. VALVE BOX TOP MUST BE METAL
- SAND OR CRUSHED LIMESTONE CONFORMING TO GRAN. A GRADATION COMPACTED TO 100% S.P.D. ALL AROUND THE CHAMBER.
- BOND BREAK TO BE USED BETWEEN ALL CONCRETE AND FITTINGS.
- MIN 12cm HIGH
- 100mm DIA. DRAIN COMPLETE WITH 'P' TRAP AND BACKWATER CHECK VALVE TO BE CONNECTED TO STORM SEWER WHERE POSSIBLE.

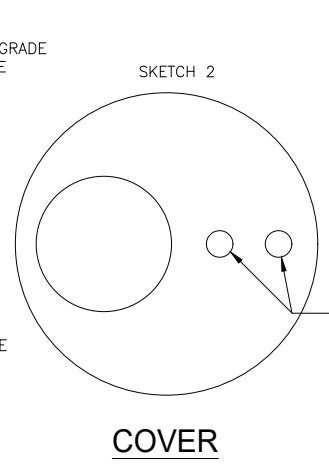

**COVER**

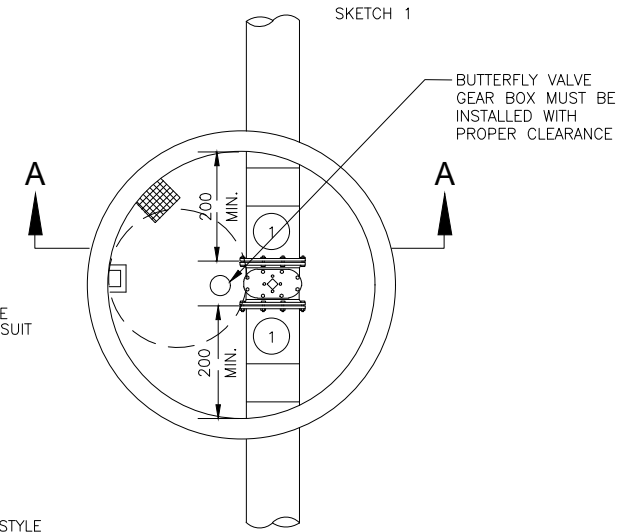

- NOTES**
1. CHAMBER TO BE DESIGNED FOR H2O LOADING AT 300mm COVER.
  2. VALVES SHALL BE FLANGED TYPE, COMPLETE WITH MECHANICAL JOINT FLANGE ADAPTER.
  3. CATHODIC PROTECTION REQUIRED ON ALL METALLIC FITTINGS.
  4. LINE VALVES TO OPEN CLOCKWISE EAST OF HWY. 400 OR NORTH OF RUTHERFORD RD., ALL OTHERS TO OPEN COUNTER-CLOCKWISE. (SEE STD. DWG. W-110)
  5. FOR PRE-CAST CHAMBER ALL JOINTS SHALL BE SET IN A MORTAR BED AND PARGED OUTSIDE.
  6. VALVES UP TO AND INCLUDING 400 mm DIAMETER SHALL BE GATE VALVES OF THE RESILIENT WEDGE TYPE, AWWA STANDARD C509. VALVES LARGER THAN 400mm SHALL BE BUTTERFLY VALVES OR AS SPECIFIED BY THE CITY.
  7. RESTRAINTS REQUIRED INSIDE CHAMBER. RESTRAINTS OUTSIDE CHAMBER REQUIRED IN ACCORDANCE WITH STD. DWG. W-105.

- LEGEND**
- ① WATERMAIN PIPE (SKETCH 1)
  - ② CONCRETE VALVE SUPPORT (MIN. 12cm)
  - ③ SOLID STEEL EXTENSION STEM
  - ④ VALVE BOX TOP SECTION
  - ⑤ ALUMINUM RUNGS AS PER OPSD 406.010
  - ⑥ PRECAST CONCRETE ADJUSTER RINGS TO BE MAX. 300 mm OTHERWISE Poured COLLARS ARE TO BE USED IN CONJUNCTION WITH RINGS.
  - ⑦ VALVE CHAMBER FRAME & COVER TO BE AS PER OPSD 401.010, LABELLED WATER SET TO FINISHED GRADE.
  - ⑧ 400 x 400 x 150 DEEP SUMP WITH REMOVABLE GALVANIZED GRATE.
  - ⑨ BRING TRACER WIRE (AWG #9) TO MODULOC UNDER LID WITH ELECTRICAL CLIP ENDS ATTACHED/FASTENED TO THE TOPMOST PORTION OF THE CHAMBER WALL
  - ⑩ 6.5m GALV. STEEL PLATE GUIDE FOR STEM EXTENSION PER OPSD 1101.020
  - ⑪ VALVE CHAMBER COVER & VALVE BOXES TO BE SET TO FINISH GRADE.

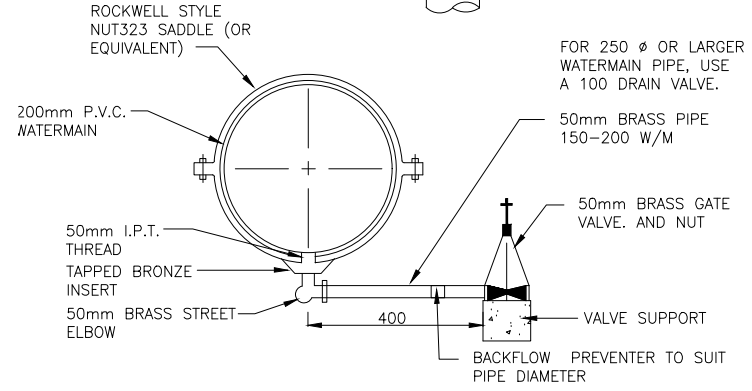

**DRAIN VALVE DETAIL WHEN REQUIRED**

4.		
3.		
2.		
1.		
REVISIONS		DATE



**CITY OF VAUGHAN ENGINEERING STANDARD**

**SINGLE VALVE IN CHAMBER**

NOT TO SCALE      DESIGNED: \_\_\_\_\_  
 REVISION: \_\_\_\_\_      DATE: DEC. 2020

STD. DWG.  
**W - 101**

**mm** DIMENSIONS IN MILLIMETRES  
 EXCEPT AS NOTED

FILE: C:\Infrastructure\Delivery\Infrastructure Programming\PMO\City Standards\Design Criteria\2020-21\City Standards Update\Folders\CoS\StandardDrawings\_CAD\_2021\W-102 - Multiple Valve Chamber.dwg

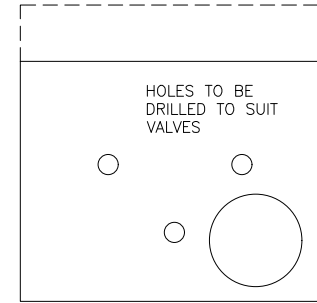
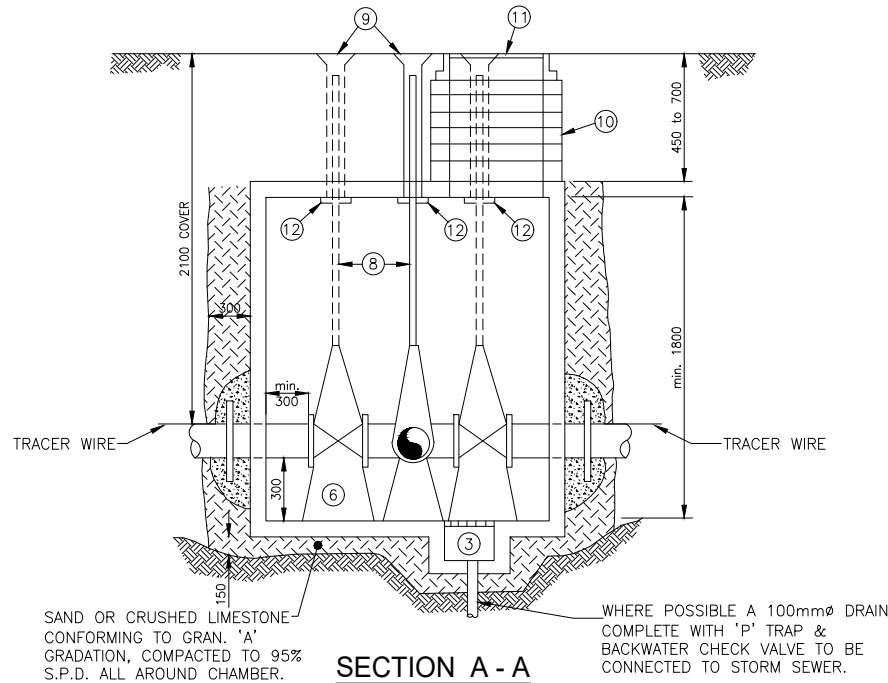
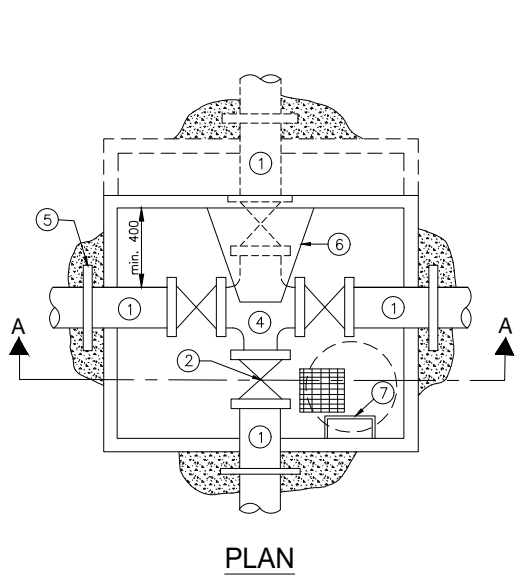

**COVER**

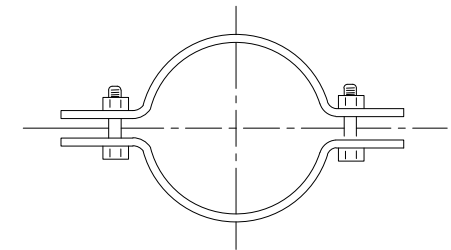

**TYPICAL PIPE ANCHOR**

**mm** DIMENSIONS IN MILLIMETRES EXCEPT AS NOTED

**NOTES**

1. CHAMBER TO BE DESIGNED FOR H2O LOADING AT 300mm COVER.
2. VALVES SHALL BE FLANGED TYPE, COMPLETE WITH MECHANICAL JOINT FLANGE ADAPTER.
3. CATHODIC PROTECTION REQUIRED ON ALL METALLIC FITTINGS.
4. LINE VALVES TO OPEN CLOCKWISE EAST OF HWY. 400 OR NORTH OF RUTHERFORD RD., ALL OTHERS TO OPEN COUNTER-CLOCKWISE. (SEE STD. DWG. W-110)
5. FOR PRE-CAST CHAMBER, ALL JOINTS SHALL BE SET IN A MORTAR BED AND PARGED OUTSIDE.
6. RESTRAINTS REQUIRED INSIDE CHAMBER. RESTRAINTS OUTSIDE CHAMBER REQUIRED IN ACCORDANCE WITH STD. DWG. W-105.
7. VALVES UP TO AND INCLUDING 400mm DIA. SHALL BE GATE VALVE OF THE RESILIENT WEDGE TYPE. TYPE AWWA STANDARD C509. VALVES LARGER THAN 400mm SHALL BE BUTTERFLY VALVE OR AS SPECIFIED BY THE CITY
8. USE CONCRETE JOINT TAPE BETWEEN LAYERS OF GRADE ADJUSTMENT UNITS.

**LEGEND**

- |   |   |
|---|---|
| <ul style="list-style-type: none"> <li>① PIPE SECTIONS WITH UNIFLANGE FITTINGS THROUGH CHAMBER WALLS.</li> <li>② FLANGE GATE VALVES</li> <li>③ 300x300x150 DEEP SUMP WITH REMOVABLE GALVANIZED GRATE</li> <li>④ FLANGE TEE OR CROSS</li> <li>⑤ PIPE ANCHOR EMBEDDED IN CONCRETE</li> <li>⑥ POURED CONCRETE SUPPORT AND THRUST BLOCKS WITH BOND BREAK FOR VALVES, TEES &amp; CROSSES.</li> <li>⑦ ALUMINUM RUNGS AS PER OPSD 406.010</li> </ul> | <ul style="list-style-type: none"> <li>⑧ SOLID STEEL EXTENSION STEM.</li> <li>⑨ VALVE BOX TOP SECTION, EACH VALVE SET TO FINISH GRADE</li> <li>⑩ PRECAST CONCRETE ADJUSTER RINGS TO BE MAX. 300 mm OTHERWISE POURED COLLARS ARE TO BE USED IN CONJUNCTION WITH RINGS.</li> <li>⑪ VALVE CHAMBER FRAME &amp; COVER TO BE AS PER OPSD 401.010, LABELLED WATER SET TO FINISHED GRADE.</li> <li>⑫ 6.5mm GALV. STEEL PLATE GUIDE FOR STEM EXTENSION PER O.P.S.D. 1101.020.</li> <li>⑬ TRACER WIRE (AWG #9) - INDEPENDENT TRACER WIRE ON EACH SECTION OF PIPE &amp; LABELLED.</li> </ul> |
|---|---|

4.		
3.		
2.		
1.		
REVISIONS		DATE



CITY OF VAUGHAN ENGINEERING STANDARD

**MULTIPLE VALVE CHAMBER**

NOT TO SCALE      DESIGNED: \_\_\_\_\_  
 REVISION: \_\_\_\_\_      DATE: DEC. 2020

STD. DWG.  
**W - 102**

FILE: G:\Infrastructure Delivery\Infrastructure Programming\PMO\City Standards\Design Criteria: 2020-21\City Standards Update Folder\CoS\StandardDrawings\_CAD\_2021\W-103 - Air Release Valve Chamber.dwg

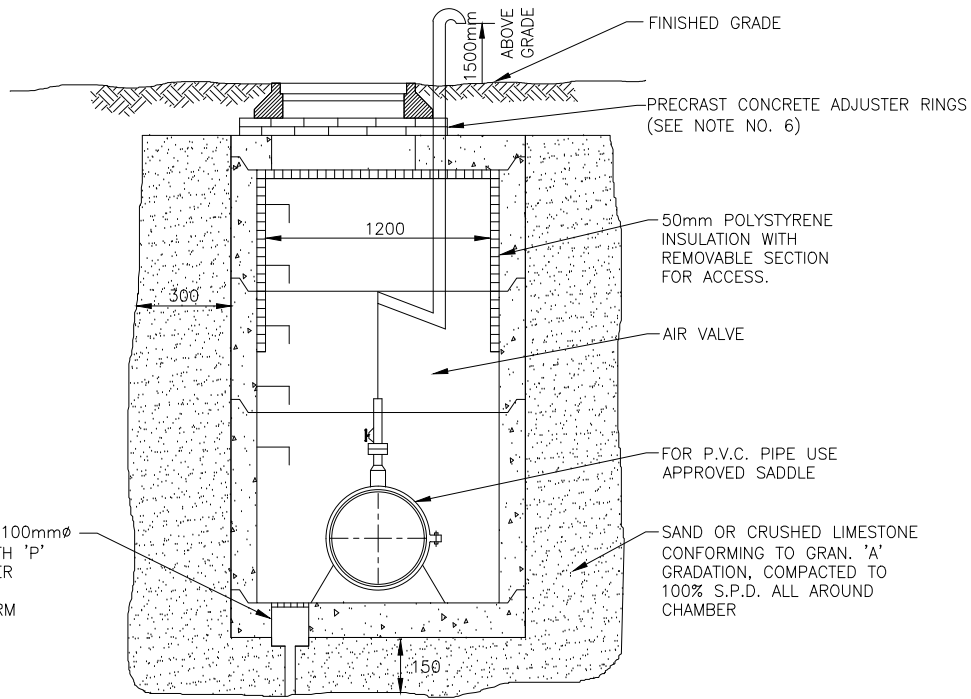

**SECTION 'A-A'**

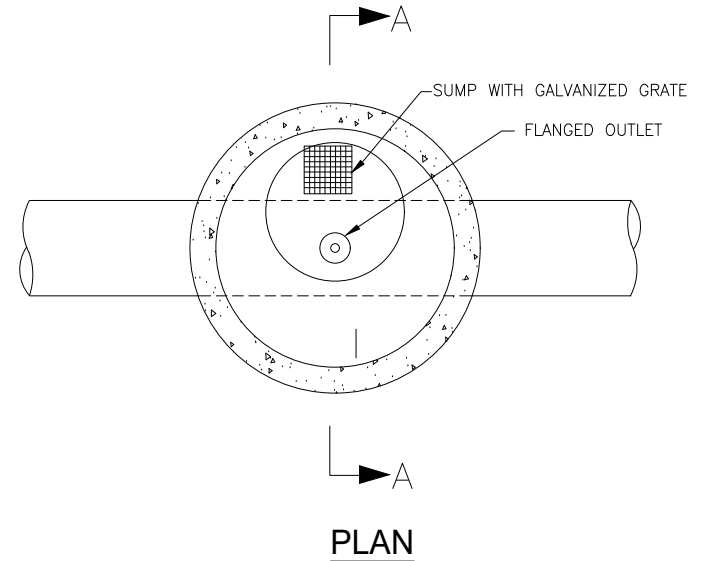

**PLAN**

**NOTES**

1. 25mm, 50mm AND 75mm AIR RELEASE/VACCUUM VALVE TO BE STAINLESS STEEL FOR SEWAGE APPLICATIONS.
2. GATE VALVE & AIR VALVE TO BE INSULATED WITH FOAMGLASS OR APPROVED EQUAL.
3. FOR PRECAST CHAMBERS ALL JOINTS SHALL BE SET IN A MORTAR BED AND PARGED OUTSIDE.
4. CONTINUOUS RUBBER GASKET BETWEEN PRECAST LAYERS.
5. AIR VENTS TO BE INSTALLED IN BOULEVARD SECTION.
6. PRECAST CONCRETE ADJUSTER RINGS (E.G. MODULOC) TO BE MAX. 300mm OTHERWISE POURED COLLARS ARE TO BE USED IN CONJUNCTION WITH RINGS.

**mm** DIMENSIONS IN MILLIMETRES EXCEPT AS NOTED

4.		
3.		
2.		
1.		
REVISIONS		DATE



CITY OF VAUGHAN ENGINEERING STANDARD

**AIR RELEASE VALVE CHAMBER**

NOT TO SCALE DESIGNED: \_\_\_\_\_

REVISION: \_\_\_\_\_ DATE: DEC. 2020

STD. DWG.

**W - 103**

FILE: C:\Infrastructure\Delivery\Infrastructure Programming\PMO\City Standards\Design Criteria\2020-21\City Standards\Update\Folders\City Standards\Drawings\_CAD\_2021\W-104 - Hydrant Installation.dwg

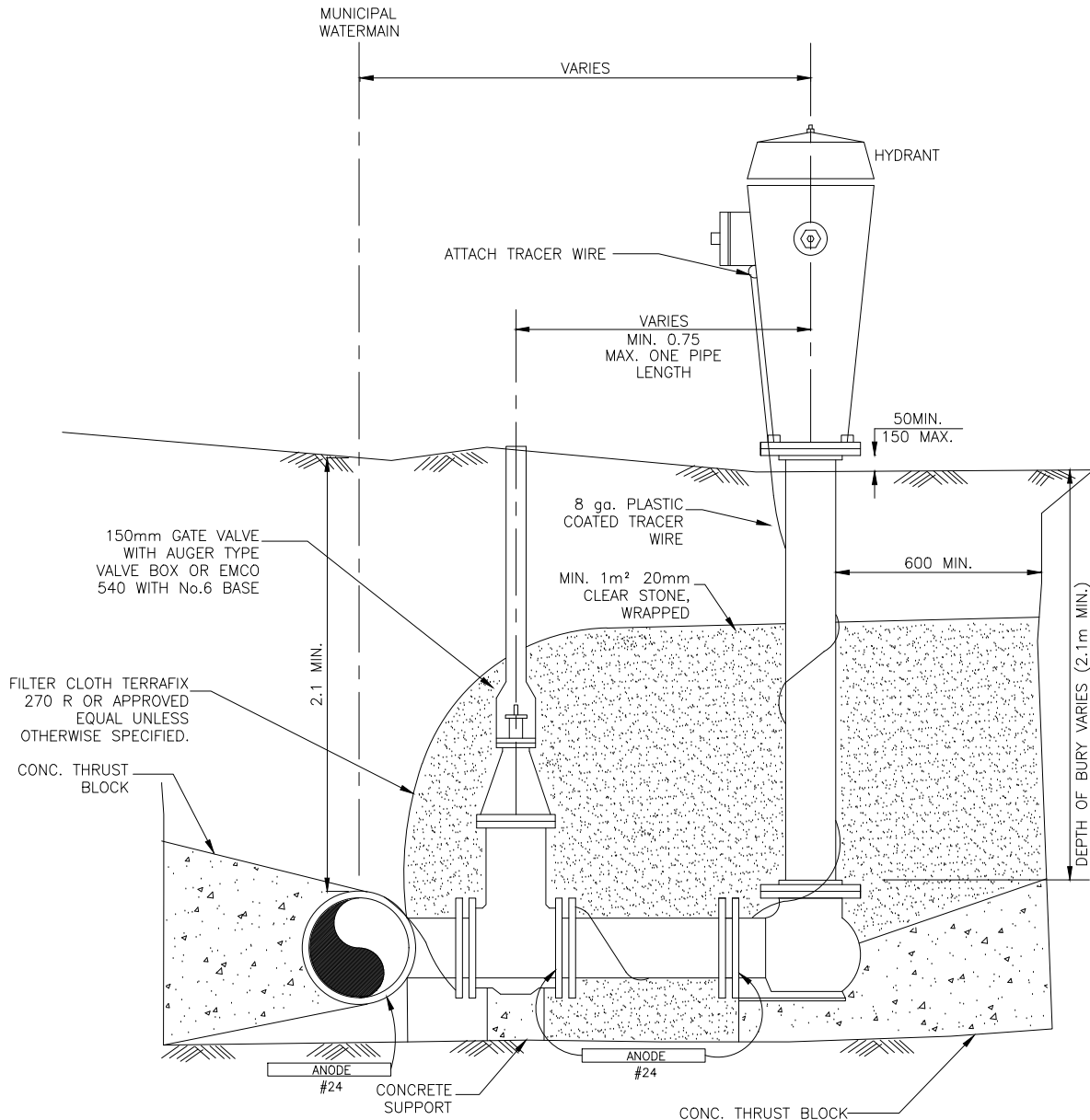

**NOTES**

1. ALL HYDRANTS LEADS TO BE 150mm DIA.
2. HYDRANTS TO BE DARLING "CENTURY" OR APPROVED EQUAL.
3. VALVE SHALL BE CONNECTED DIRECTLY TO MUNICIPAL WATERMAIN ANCHOR TEE UNLESS OTHERWISE DIRECTED BY THE CITY.
4. CONCRETE TO BE 20 MPa AT 28 DAYS.
5. ALL CONCRETE THRUST BLOCKS TO BE POURED AGAINST UNDISTURBED GROUND.
6. STONE SHALL BE COMPLETELY ENVELOPED BY FILTER CLOTH.
7. ALL HYDRANTS TO OPEN COUNTER CLOCKWISE.
8. DEPTH OF HYDRANT VARIES ACCORDING TO LOCAL TOPOGRAPHY.
9. 100mm DIA. STORZ CONNECTION ON PUMPER NOZZLE.
10. STORZ CONNECTIONS TO FIRE HYDRANTS TO BE PAINTED BLACK.
11. SECONDARY VALVES TO OPEN CLOCKWISE EAST OF HWY. #400 OR NORTH OF RUTHERFORD ROAD. ALL OTHERS TO OPEN COUNTERCLOCKWISE.
12. DRAIN HOLES TO BE PLUGGED IN AREAS WHERE HYDRANT VALVES ARE INSTALLED BELOW THE GROUND WATER TABLE.
13. CATHODIC PROTECTION REQUIRED ON ALL METALLIC FITTINGS.
14. POLYETHYLENE BOND BREAKER TO BE USED BETWEEN CONCRETE AND FITTINGS.
15. SECONDARY VALVES TO BE LOCATED IN BLVD. (NOT ON ROAD) AND SET TO FINISH GRADE.
16. ONCE THE TRACER WIRE HAS BEEN INSTALLED AND CONSTRUCTION IS COMPLETE, A CONTINUITY TEST SHOULD BE CONDUCTED TO CONFIRM THAT THE TRACER WIRE IS CONTINUOUS AND REMAINS INTACT. IF THERE IS A BREAKAGE IN THE WIRE, THE CONTRACTOR IS RESPONSIBLE TO REPLACE IT AT THEIR OWN COST.

4.		
3.		
2.		
1.		
REVISIONS		DATE



CITY OF VAUGHAN ENGINEERING STANDARD

**HYDRANT INSTALLATION**

**mm** DIMENSIONS IN MILLIMETRES  
EXCEPT AS NOTED

NOT TO SCALE      DESIGNED: \_\_\_\_\_

REVISION: \_\_\_\_\_      DATE: DEC. 2020

STD. DWG.

**W - 104**



FILE: C:\Users\audiemop\CITY OF VAUGHAN\City Standards - General\Design Criteria 2023\Dev - Standards\CAD\W-105 - Restraining of P.V.C. Watermain Valves & Fittings.dwg

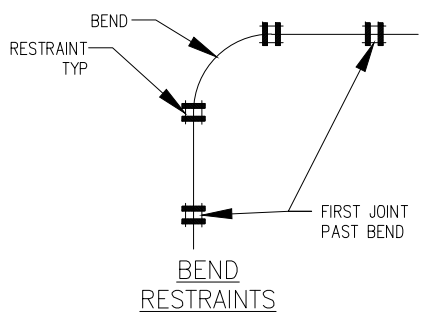
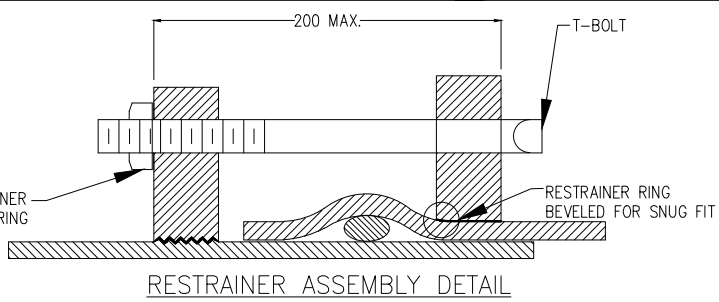
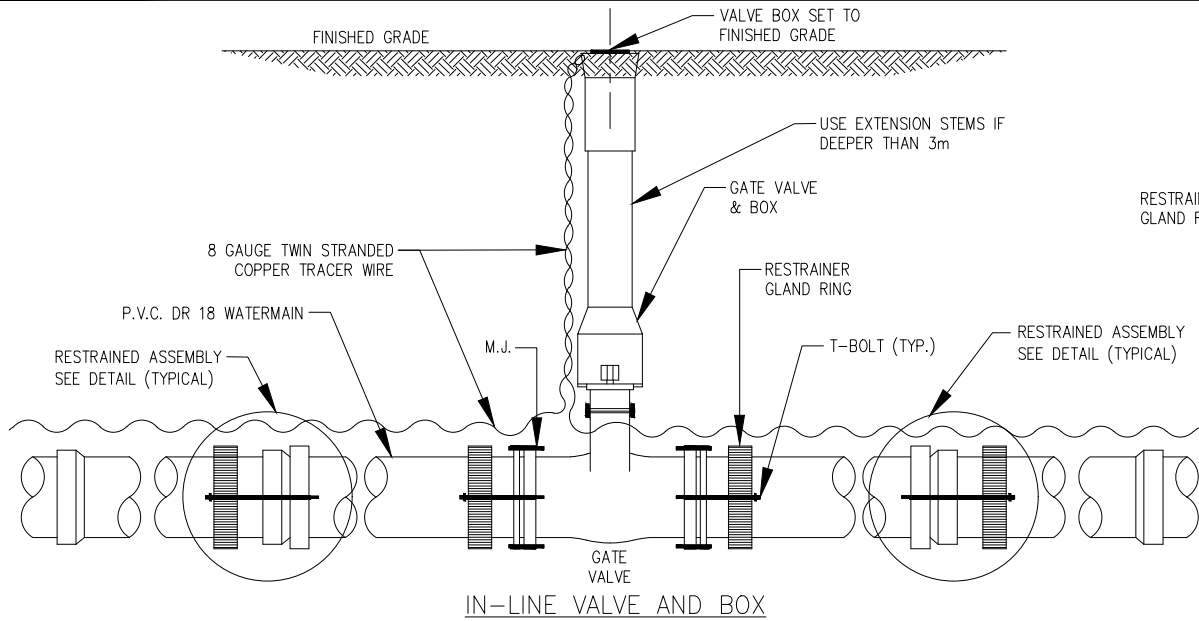

BEND RESTRAINTS

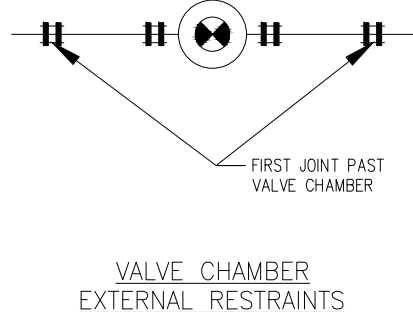

VALVE CHAMBER EXTERNAL RESTRAINTS

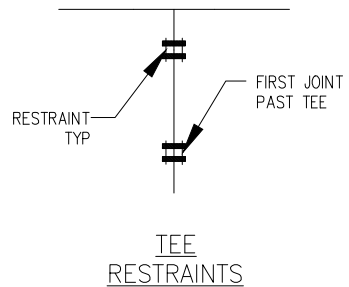

TEE RESTRAINTS

**NOTES**

1. ALL JOINTS WITHIN 2 PIPE LENGTHS EACH SIDE FROM GATE VALVE SHALL BE RESTRAINED WITH MECHANICAL JOINT RESTRAINTS
2. MECHANICAL RESTRAINTS SHALL BE EITHER "UNIFLANGE" OR "MEGALUG" BRAND OR APPROVED EQUIVALENT, AND ARE TO BE USED AS FOLLOWS:
  - AT 45°, 22½, AND 11¼ HORIZONTAL AND VERTICAL BENDS – ONE PIPE LENGTH EACH WAY;
  - AT TEES – TWO PIPE LENGTHS EACH WAY;
  - AT REDUCERS – TWO PIPE LENGTHS EACH WAY;
  - AT DEAD END – THREE PIPE LENGTHS;
  - AT VALVES – TWO PIPE LENGTHS EACH WAY (EXCLUDING VALVE CHAMBERS);

NOTE: JOINT RESTRAINTS ARE NOT REQUIRED FOR PIPES CONNECTED WITH HDD CONNECTION JOINTS. (E.G. TERRA BRUTE OR COBRA LOCK JOINTS).
3. CATHODIC PROTECTION (6 LB ANODE) REQUIRED ON ALL RESTRAINERS.
4. WATERMAIN TO BE RESTRAINED IN ALL FILL AREAS, AREAS ANTICIPATED TO BE DISTURBED AND OR AS DIRECTED BY THE CITY
5. WATER REPELLENT COATING WRAP ALL THROW AWAY VALVES AS PER SECTION 1.5.4.6 CORROSION PROTECTION OF METALLIC FITTINGS.

**mm** DIMENSIONS IN MILLIMETRES EXCEPT AS NOTED

4.		
3.		
2.		
1.	UPDATED NOTES 4 & 5	03/24
	REVISIONS	DATE



CITY OF VAUGHAN ENGINEERING STANDARD

**RESTRAINING OF P.V.C. WATERMAIN AT VALVES AND FITTINGS**

NOT TO SCALE      DESIGNED: \_\_\_\_\_      STD. DWG.  
 REVISION: 1      DATE: DEC. 2020      **W - 105**

FILE: C:\Infrastructure Delivery\Infrastructure Programming\PMO\City Standards\Design Criteria\2020-21\City Standards Update\Folders\CoStandardDrawings\_CAD\_2021\W-106 - Meter, Backflow Preventer in Chamber.dwg

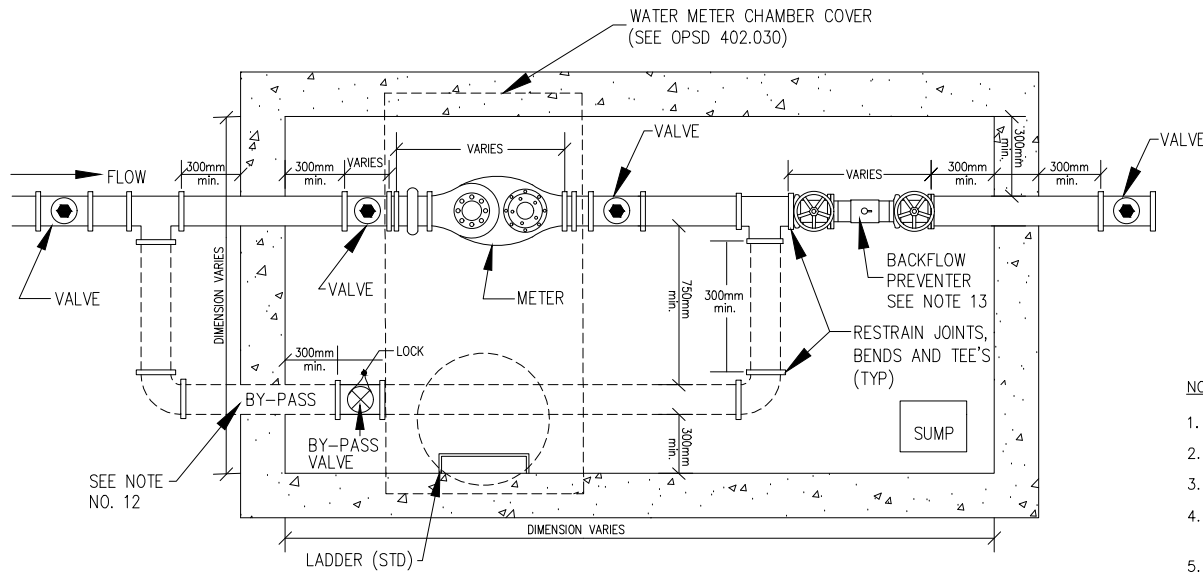

**PLAN VIEW**

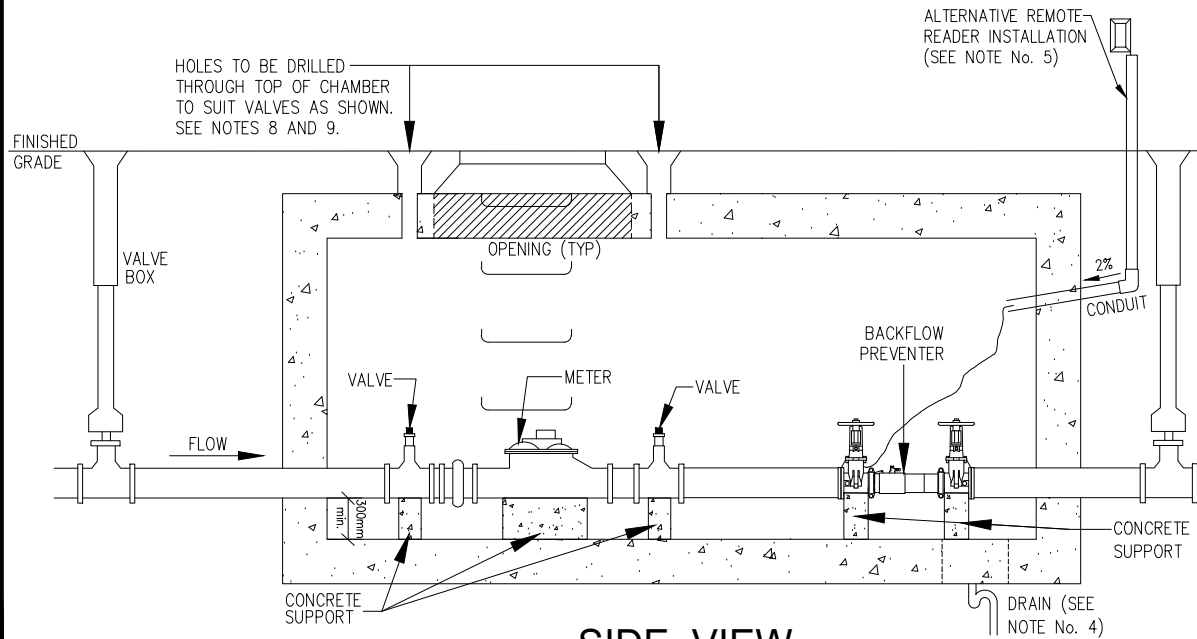

**SIDE VIEW**

**mm** DIMENSIONS IN MILLIMETRES EXCEPT AS NOTED

**TYPICAL INSTALLATION**

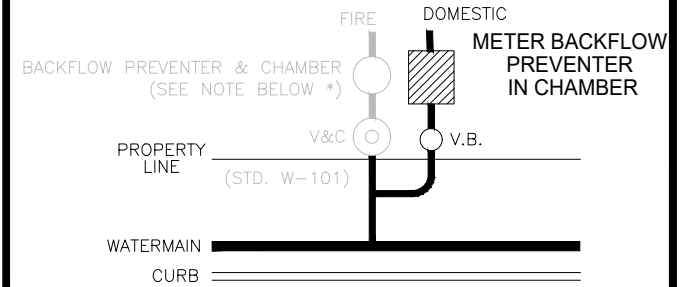

\* BACKFLOW PREVENTER SHALL BE INSTALLED PER STD. W-111 WHEN HYDRANT CONNECTION IS PROPOSED FOR THE DEVELOPMENT

**NOTES:**

1. CONCRETE TO BE 32MPa COMPRESSIVE STRENGTH.
2. COPPER PIPE TO BE TYPE K.
3. CHAMBER COVER & FRAME TO BE 2 PIECE.
4. 100mm DIA. DRAIN COMPLETE WITH 'P' TRAP AND BACK WATER VALVE TO BE CONNECTED TO STORM SEWER.
5. 50mm CONDUIT TO BE INSTALLED FROM CHAMBER WALL TO AN ACCESSIBLE AND PERMANENT LOCATION APPROVED BY THE CITY.
6. CHAMBER TO BE DESIGNED FOR H2O LOADING AT 300mm COVER.
7. DIMENSIONS OF THE CHAMBER AND ALL INTERNAL CONNECTIONS SHALL BE VERIFIED BEFORE INSTALLATION.
8. VALVES TO BE EQUIPPED WITH KEY TYPE OPERATING NUT.
9. 6.5mm GALV. STEEL PLATE GUIDE FOR STEM EXTENSION PER O.P.S.D. 1101.020.
10. SEE STANDARD DRAWING W-101, W-107 & W-111 FOR ADDITIONAL NOTES.
11. BYPASS PIPE TO BE ONE (1) PIPE SIZE SMALLER THAN SERVICE CONNECTION OR MINIMUM 2" DIAMETER.
12. NO PERSON SHALL INSTALL OR PERMIT THE INSTALLATION OF A BYPASS UNLESS AUTHORIZED BY THE CITY AND THE BYPASS IS VALVED AND LOCKED BY THE CITY.
13. BACKFLOW DEVICE TO BE SELECTED, INSTALLED AND TESTED IN THE CONFORMANCE WITH CSA B64 "SELECTION INSTALLATION OF BACKFLOW PREVENTERS AND AS PER MANUFACTURE RECOMMENDATIONS".

4.		
3.		
2.		
1.		
REVISIONS		DATE



CITY OF VAUGHAN ENGINEERING STANDARD

**METER, BACKFLOW PREVENTER IN CHAMBER**

NOT TO SCALE      DESIGNED: \_\_\_\_\_

REVISION: \_\_\_\_\_      DATE: DEC. 2020

STD. DWG.

**W - 106**

FILE: C:\Infrastructure\Delivery\Infrastructure Programming\PMO\City Standards\Design Criteria\2020-21\City Standards Update\Folder\CoStandardDrawings\_CAD\_2021\W-107 - Meter Chamber for Copper Services.dwg

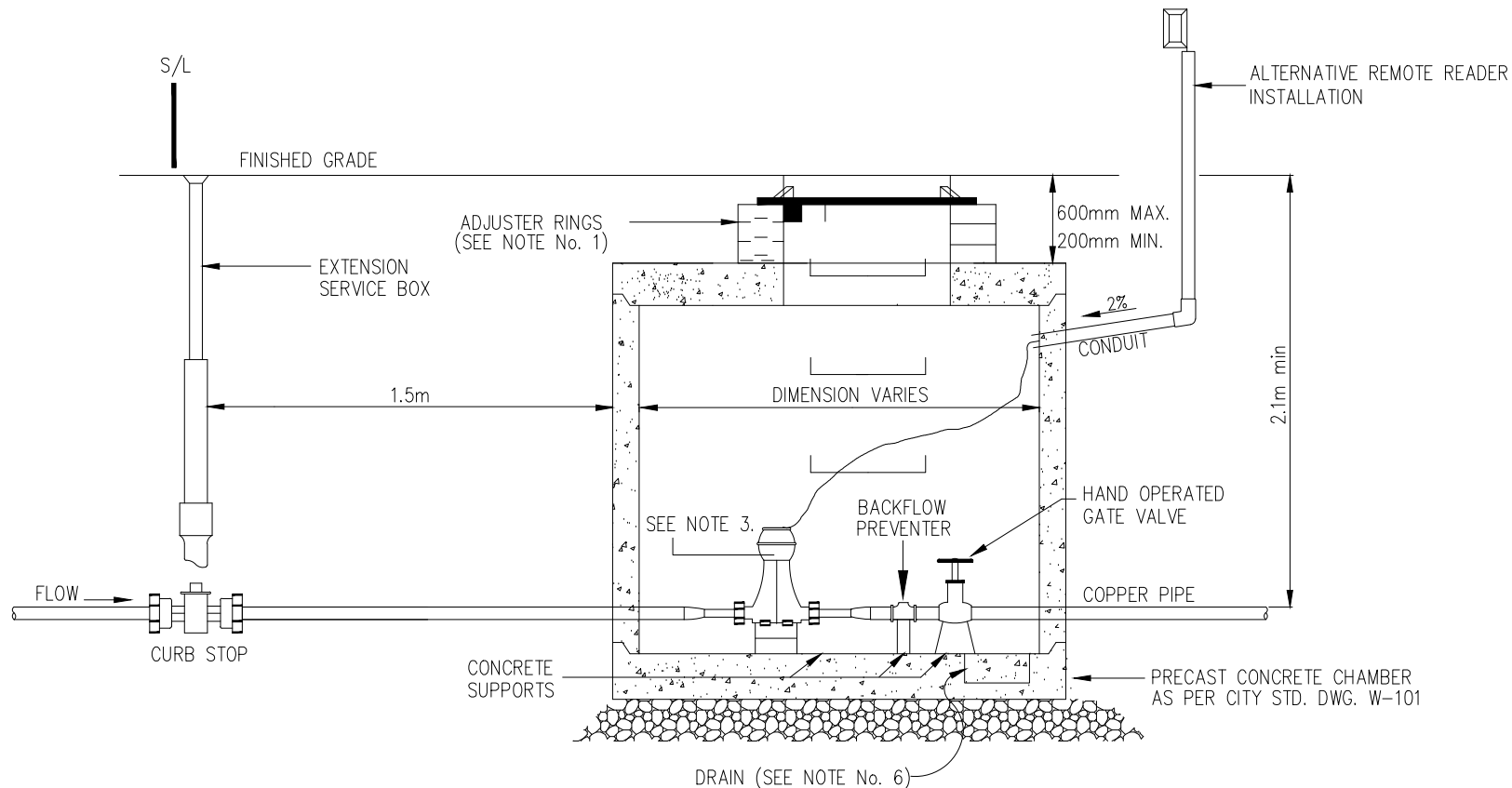

**NOTES**

1. PRECAST CONCRETE ADJUSTER RINGS (E.G., MOUDLOC) TO BE MAX. 300 mm OTHERWISE POURED COLLARS ARE TO BE USED IN CONJUNCTION WITH RINGS. MODULOC TAPE TO BE PLACED BETWEEN RINGS.
2. 50mm CONDUIT TO BE INSTALLED FROM CHAMBER WALL TO AN ACCESSIBLE AND PERMANENT LOCATION APPROVED BY THE CITY.
3. REDUCERS AS REQUIRED FOR 40mm AND 50mm METER INSTALLATIONS.
4. 'FORD' LOC PAK COUPLING OR APPROVED EQUAL REQUIRED FOR 40mm AND 50mm METERS.
5. FOR PRE-CAST CHAMBER ALL JOINTS SHALL BE SET IN A MORTAR BED AND PARGED OUTSIDE.
6. 100mm DIA. DRAIN COMPLETE WITH 'P' TRAP AND BACK WATER VALVE TO BE CONNECTED TO STORM SEWER.
7. CONCRETE SUPPORTS TO BE 20MP<sub>a</sub> COMPRESSIVE STRENGTH.
8. COPPER PIPE TO BE TYPE K HARD.
9. SEE STANDARD DRAWING W-101, W-106 & W-111 FOR ADDITIONAL NOTES.

**mm** DIMENSIONS IN MILLIMETRES EXCEPT AS NOTED

4.		
3.		
2.		
1.		
REVISIONS		DATE



CITY OF VAUGHAN ENGINEERING STANDARD

**METER CHAMBER FOR COPPER SERVICES**

NOT TO SCALE      DESIGNED: \_\_\_\_\_  
 REVISION: \_\_\_\_\_      DATE: DEC. 2020

STD. DWG.  
**W - 107**

## **W-108 - INTENTIONALLY LEFT BLANK**

*Refer to 2004 Published Edition. Should drawing not be available, please contact the  
Development Engineering Department at [developmentengineering@vaughan.ca](mailto:developmentengineering@vaughan.ca)*

FILE: G:\Infrastructure Delivery\Infrastructure Programming\PMO\City Standards\Design Criteria 2020-21\City Standards Update Folder\CovStandardsDrawings\_CAD\_2021\W-109 - Industrial-Commercial Meter w. Backflow Preventer & Valve Installation.dwg

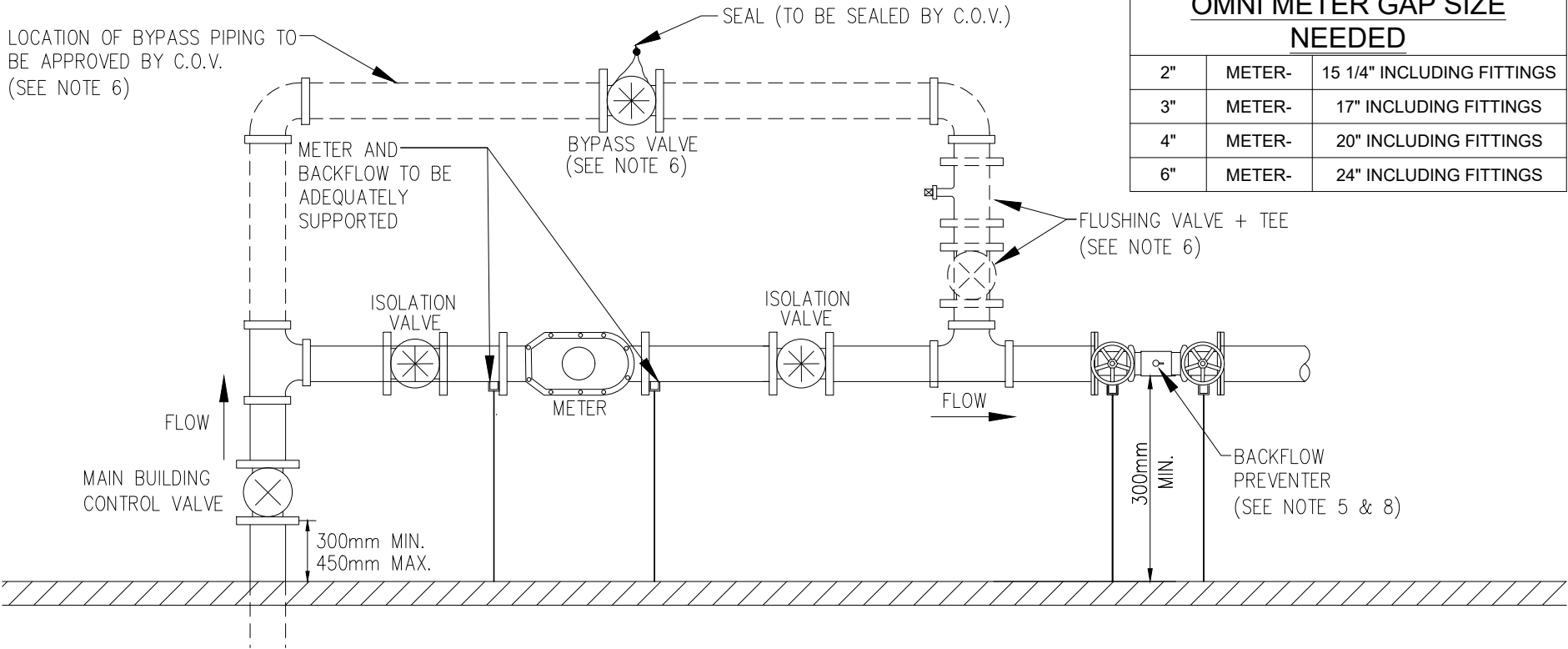

OMNI METER GAP SIZE NEEDED		
2"	METER-	15 1/4" INCLUDING FITTINGS
3"	METER-	17" INCLUDING FITTINGS
4"	METER-	20" INCLUDING FITTINGS
6"	METER-	24" INCLUDING FITTINGS

**NOTES:**

- MUST HAVE FULLY FUNCTIONAL ISOLATION VALVES:
  - ON INLET SIDE TO METER
  - ON OUTLET SIDE TO METER
- SHALL BE NO CONNECTIONS BEFORE THE METER AND PREMISE BACKFLOW DEVICE.
- BYPASS NEEDED FOR SERVICES 2" AND GREATER. BYPASS PIPE TO BE ONE (1) PIPE SIZE SMALLER THAN SERVICE CONNECTION OR MINIMUM 2" DIAMETER.
- STRAINER NOT REQUIRED WITH OMNI METERS.
- BACKFLOW DEVICE TO BE SELECTED, INSTALLED AND TESTED IN CONFORMANCE WITH C.S.A. B64. SELECTION AND INSTALLATION OF BACKFLOW PREVENTERS AND AS PER MANUFACTURE RECOMMENDATIONS.
- NO PERSON SHALL INSTALL OR PERMIT THE INSTALLATION OF A BYPASS UNLESS AUTHORIZED BY THE CITY AND THE BYPASS IS VALVED AND LOCKED PROPERLY. IF APPROVED LOCKABLE FLUSHING VALVE AND TEE ARE TO BE INSTALLED.
- REMOTE READER TO BE ACCESSIBLE FROM OUTSIDE BUILDING.
- BACKFLOW DEVICE TO COMPLY WITH WITH BYLAW 004-2018 AS AMENDED.
- WHERE METER ROOM IS NOT ADJACENT TO AN OUTSIDE WALL OR IS BELOW EXTERIOR FINISHED GRADE, CONTRACTOR/APPLICANT SHALL PROVIDE A CONTINUOUS CONDUIT, COMPLETE WITH NYLON FINISH LINE FROM METER ROOM TO 1000mm ABOVE EXTERIOR FINISHED GRADE.
- BACKFLOW DEVICES ARE PERMITTED TO BE INSTALLED IN PARALLEL ARRANGEMENTS IN ORDER TO ALLOW UNINTERRUPTED SERVICE DURING BACKFLOW MAINTENANCE.
- ALL PIPING BETWEEN WATER METER AND BACFLOW DEVICE TO BE CLEARLY AND PERMANENTLY LABELLED "NO CONNECTION PERMITTED".

IF RP DEVICE IS INSTALLED DRAINAGE IS REQUIRED AS PER CSA B64. 10-17, 6.8.1 + 6.8.2

4.		
3.		
2.		
1.		
REVISIONS		DATE



**CITY OF VAUGHAN ENGINEERING STANDARD**  
**INDUSTRIAL / COMMERCIAL**  
**METER with BACKFLOW PREVENTER AND**  
**VALVE INSTALLATION (METER ROOM)**

NOT TO SCALE      DESIGNED: \_\_\_\_\_      STD. DWG.  
 REVISION: \_\_\_\_\_      DATE: DEC. 2020      **W - 109**

**mm** DIMENSIONS IN MILLIMETRES  
EXCEPT AS NOTED

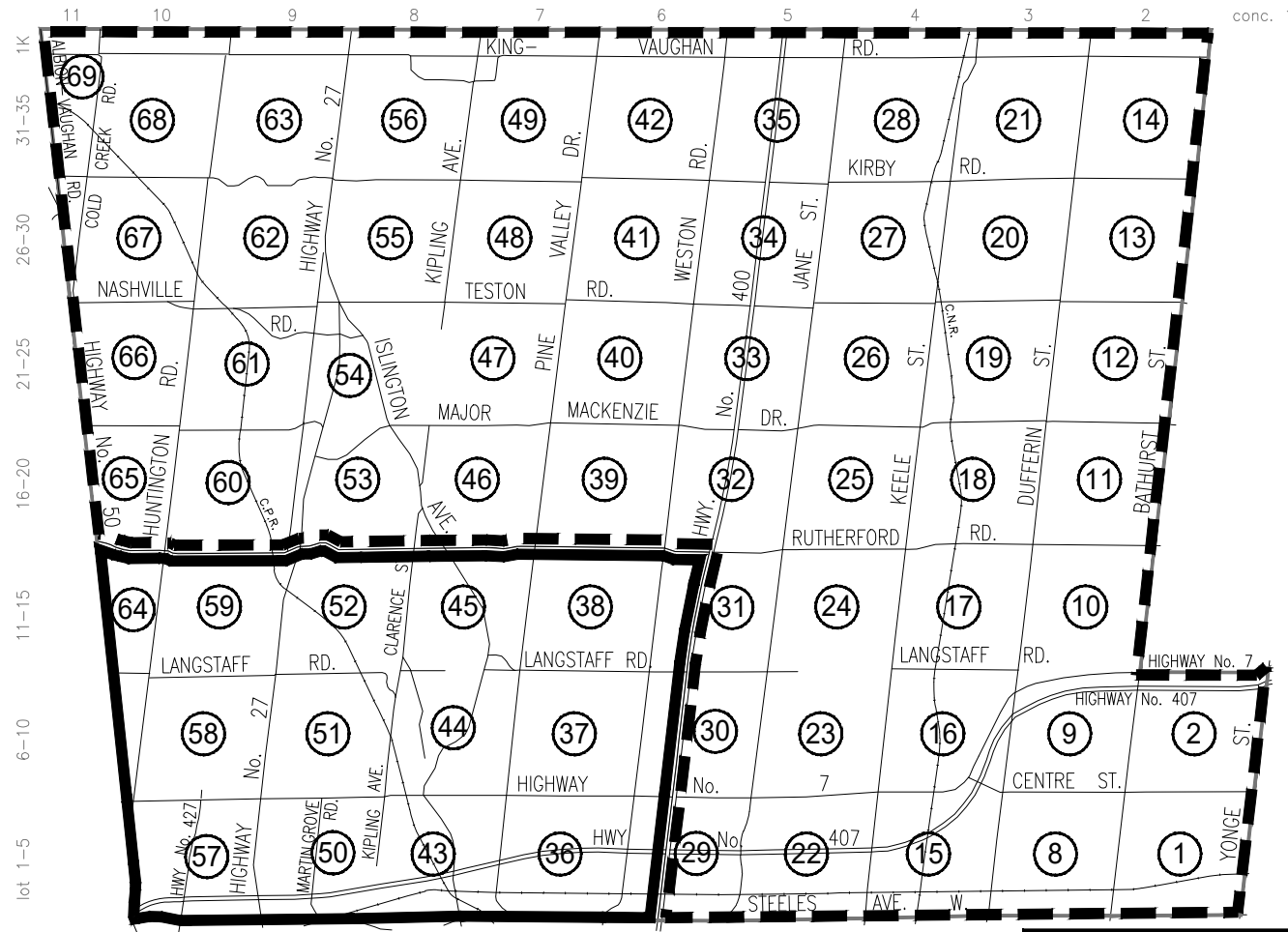

conc. 1

NOTE  
NUMBERS IN CIRCLES ARE  
DESIGNATED AS 'BLOCK'  
NUMBERS.



TURN COUNTER-CLOCKWISE  
LEFT TO OPEN  
RIGHT TO CLOSE



TURN CLOCKWISE  
RIGHT TO OPEN  
LEFT TO CLOSE

NOTE

1. ALL WATER, HYDRANT SEC. VALVES TO OPEN CLOCKWISE EAST OF HWY. 400 OR NORTH OF RUTHERFORD ROAD. ALL OTHERS TO OPEN COUNTER-CLOCKWISE.
2. ALL HYDRANTS OPEN COUNTER CLOCKWISE

4.		
3.		
2.		
1.		
REVISIONS		DATE



CITY OF VAUGHAN ENGINEERING STANDARD

**WATER VALVE  
OPEN / CLOSE DIRECTION**

NOT TO SCALE      DESIGNED: \_\_\_\_\_  
REVISION: \_\_\_\_\_      DATE: \_\_\_\_\_ DEC. 2020

STD. DWG.  
**W - 110**

FILE: G:\Infrastructure Delivery\Infrastructure Programming\PMO\City Standards\Design Criteria\2020-21\City Standards Update\Folders\CoS\StandardDrawings\_CAD\_2021\W-111 - Backflow Preventer & Chamber.dwg

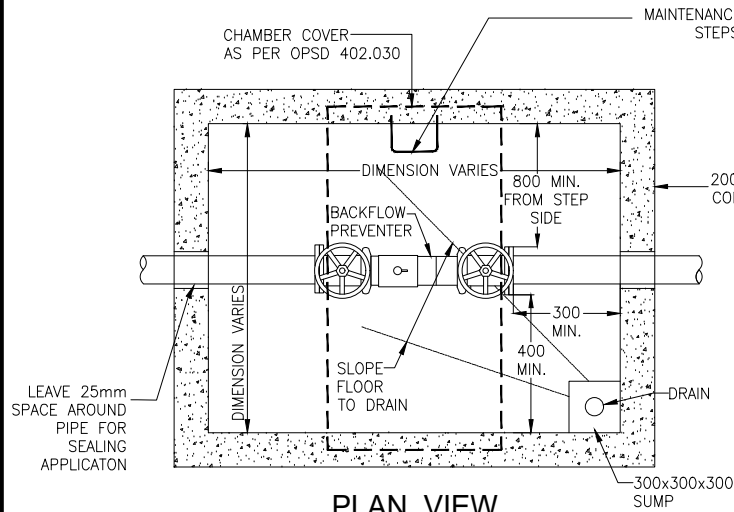

**PLAN VIEW**

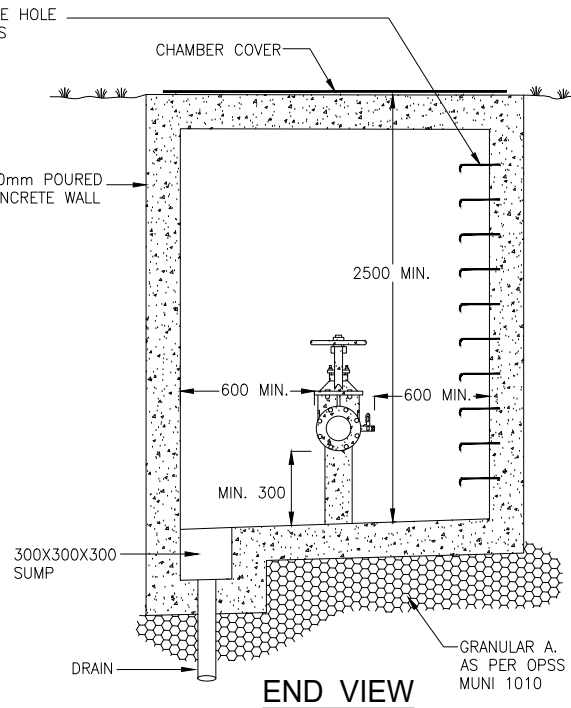

**END VIEW**

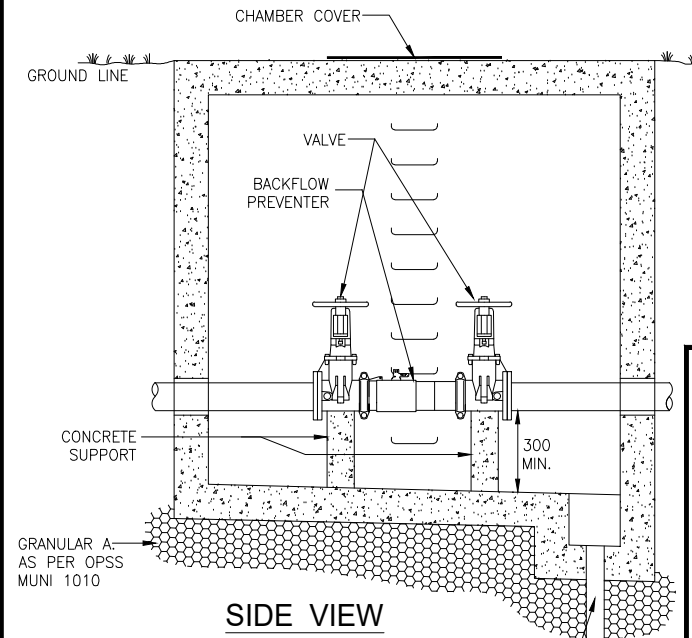

**SIDE VIEW**

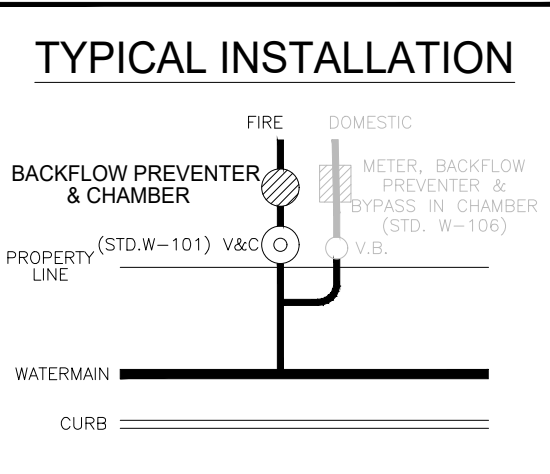

**TYPICAL INSTALLATION**

**NOTES:**

1. BACKFLOW DEVICE TO BE SELECTED, INSTALLED AND TESTED IN CONFORMANCE WITH CSA B64 "SELECTION + INSTALLATION OF BACKFLOW PREVENTERS AND AS PER MANUFACTURER RECOMMENDATIONS.
2. BACKFLOW DEVICE TO COMPLY WITH BY-LAW 004-2018 AS AMENDED.
3. REDUCED PRESSURE ASSEMBLY (RP) BACKFLOW PREVENTER ARE NOT PERMITTED IN BELOW GROUND APPLICATIONS.
4. BACKFLOW DEVICE TO REMAIN ACCESSIBLE AT ALL TIMES.
5. THIS DRAWING INDICATES MINIMUM CLEARANCE AND ACCESS ONLY.
6. CHAMBER TO BE OF WATER TIGHT CONSTRUCTION.
7. 100mm DIA. DRAIN COMPLETE WITH 'P' TRAP AND BACK WATER PREVENTER VALVE TO BE CONNECTED TO STORM SEWER.
8. MAINTENANCE HOLE STEPS AS PER OPSD 405.020
9. TEST COCKS ARE TO BE PROTECTED WITH WATER TIGHT PLUGS.
10. MINIMUM DEPTH OF CHAMBER = 2.5 METRES.
11. AS PER ONTARIO BUILDING CODE SECTION 7.6.2.2:
  - A) EVERY POTABLE WATER SYSTEM THAT SUPPLIES A FIXTURE OR TANK THAT IS NOT SUBJECT TO PRESSURE ABOVE ATMOSPHERIC SHALL BE PROTECTED AGAINST BACK-SIPHONAGE BY A BACKFLOW PREVENTER.
  - B) WHERE A POTABLE WATER SUPPLY IS CONNECTED TO A TANK, COOLING JACKET, LAWN SPRINKLER SYSTEM, YARD HYDRANT OR OTHER DEVICE WHERE A NON-PORTABLE FLUID MAY BE UNDER PRESSURE THAT IS ABOVE ATMOSPHERIC OR THE WATER OUTLET MAY BE SUBMERGED IN THE NON-PORTABLE FLUID, THE WATER SUPPLY SHALL BE PROTECTED AGAINST BACKFLOW BY A BACKFLOW PREVENTER.
  - C) WHERE A HOSE BIB IS INSTALLED OUTSIDE A BUILDING, INSIDE A GARAGE, OR WHERE THERE IS AN IDENTIFIABLE RISK OF CONTAMINATION, THE POTABLE WATER SYSTEM SHALL BE PROTECTED AGAINST BY A BACKFLOW PREVENTER.
12. WHERE PRECAST CONCRETE ADJUSTER RINGS (E.G., MODULOC) ARE REQUIRED, THEY ARE TO BE MAX. 300 mm OTHERWISE POURED COLLARS ARE TO BE USED IN CONJUNCTION WITH RINGS.
13. THIS STANDARD APPLIES TO BUILDINGS WITH OUTSIDE HYDRANTS
14. DIMENSIONS OF THE CHAMBER AND ALL INTERNAL CONNECTION SHALL BE VERIFIED BEFORE INSTALLATION.

4.		
3.		
2.		
1.		
REVISIONS		DATE



**CITY OF VAUGHAN ENGINEERING STANDARD  
BACKFLOW PREVENTER & CHAMBER  
FOR 100mm THROUGH 300mm  
DOUBLE CHECK VALVE ASSEMBLY**

**mm** DIMENSIONS IN MILLIMETRES  
EXCEPT AS NOTED

NOT TO SCALE      DESIGNED: \_\_\_\_\_  
REVISION: \_\_\_\_\_      DATE: DEC. 2020

STD. DWG.  
**W - 111**

**W-112 - TEMPORARY SUPPLY AND DISINFECTION CONNECTION**  
*CURRENTLY UNDER DEVELOPMENT*

*Refer to 2004 Published Edition. Should drawing not be available, please contact the  
Development Engineering Department at [developmentengineering@vaughan.ca](mailto:developmentengineering@vaughan.ca)*



### CONNECTION SIZE

WATERMAIN SIZE	MIN. BYPASS SIZE
< 150mm	50mm
200mm - 400mm	100mm
> 450mm	Size to be approved by the City

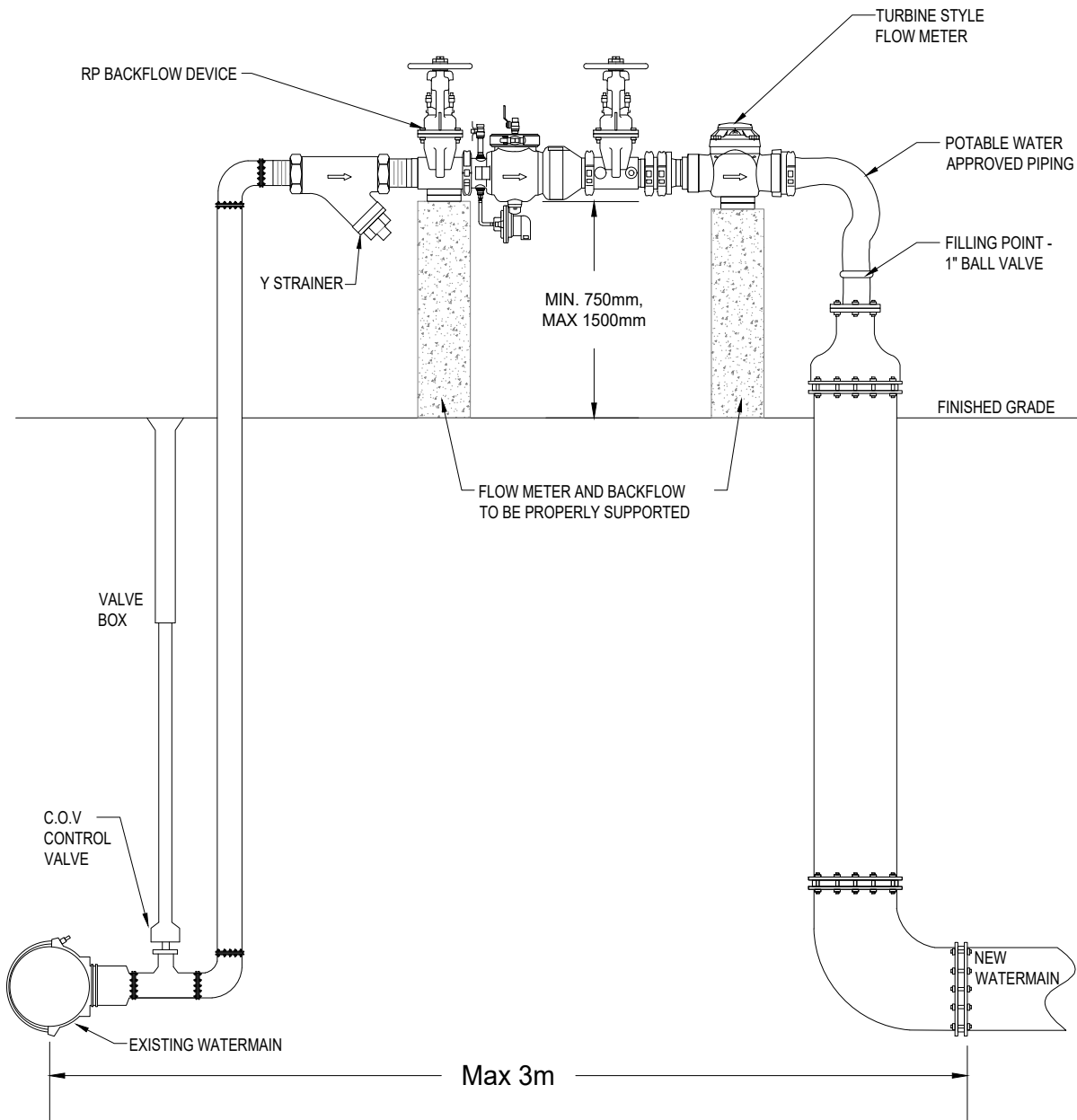

**NOTES:**

1. BACKFLOW DEVICE MUST BE A REDUCED PRESSURE PRINCIPLE ASSEMBLY (RP) AND IN CONFORMITY WITH CSA B64.10. BACKFLOW TO BE SUPPLIED AND TESTED BY APPLICANT.
2. BACKFLOW TO BE FIELD TESTED BY A CROSS-CONNECTION CONTROL SPECIALIST WITH VALID OWWA TESTER CERTIFICATE. CITY OF VAUGHAN OPERATOR TO WITNESS ALL FIELD TESTING OF THE BACKFLOW ASSEMBLY. BACKFLOW MUST BE RE-TESTED WHEN RELOCATED, REPAIRED OR REPLACED.
3. BACKFLOW DEVICE TO BE DISCONNECTED FROM BYPASS PIPING DURING WATERMAIN PRESSURE TESTS.
4. ALL NEW PIPING AND FITTINGS TO BE DISINFECTED WITH 1-5% SODIUM HYPOCHLORITE SOLUTION ACCORDING TO AWWA C651.
5. ONLY CITY OF VAUGHAN STAFF TO OPERATE HYDRANT & MUNICIPALITY OWNED VALVES. APPLICANT/CONTRACTOR ARE NOT PERMITTED TO TURN HYDRANT ON/OFF.
6. APPLICANT/CONTRACTOR TO BE RESPONSIBLE FOR ANY DAMAGE TO CITY OF VAUGHAN AND/OR PRIVATE PROPERTY.
7. FREEZING PROTECTION MUST BE PROVIDED AND INSTALLED BY THE APPLICANT WHEN APPLICABLE.

4.		
3.		
2.		
1.		
REVISIONS		DATE



CITY OF VAUGHAN ENGINEERING STANDARD

## WATERMAIN BYPASS SETUP

SIDE VIEW

**mm** DIMENSIONS IN MILLIMETRES  
EXCEPT AS NOTED

NOT TO SCALE      DESIGNED: \_\_\_\_\_  
 REVISION: \_\_\_\_\_      DATE: \_\_\_\_\_ JAN. 2021

STD. DWG.  
**W - 113**

Acad File: \\vis2\Dep\Share\$\Infrastructure\Delivery\Infrastructure Programming\PMO\City Standards\Design Criteria 2016\City Standards Update Folder\CoVStandardDrawings\_CAD\_2021\W-114--.dwg

CONNECTION SIZE	
WATERMAIN SIZE	MIN. BYPASS SIZE
< 150mm	50mm
200mm - 400mm	100mm
> 450mm	Size to be approved by the City

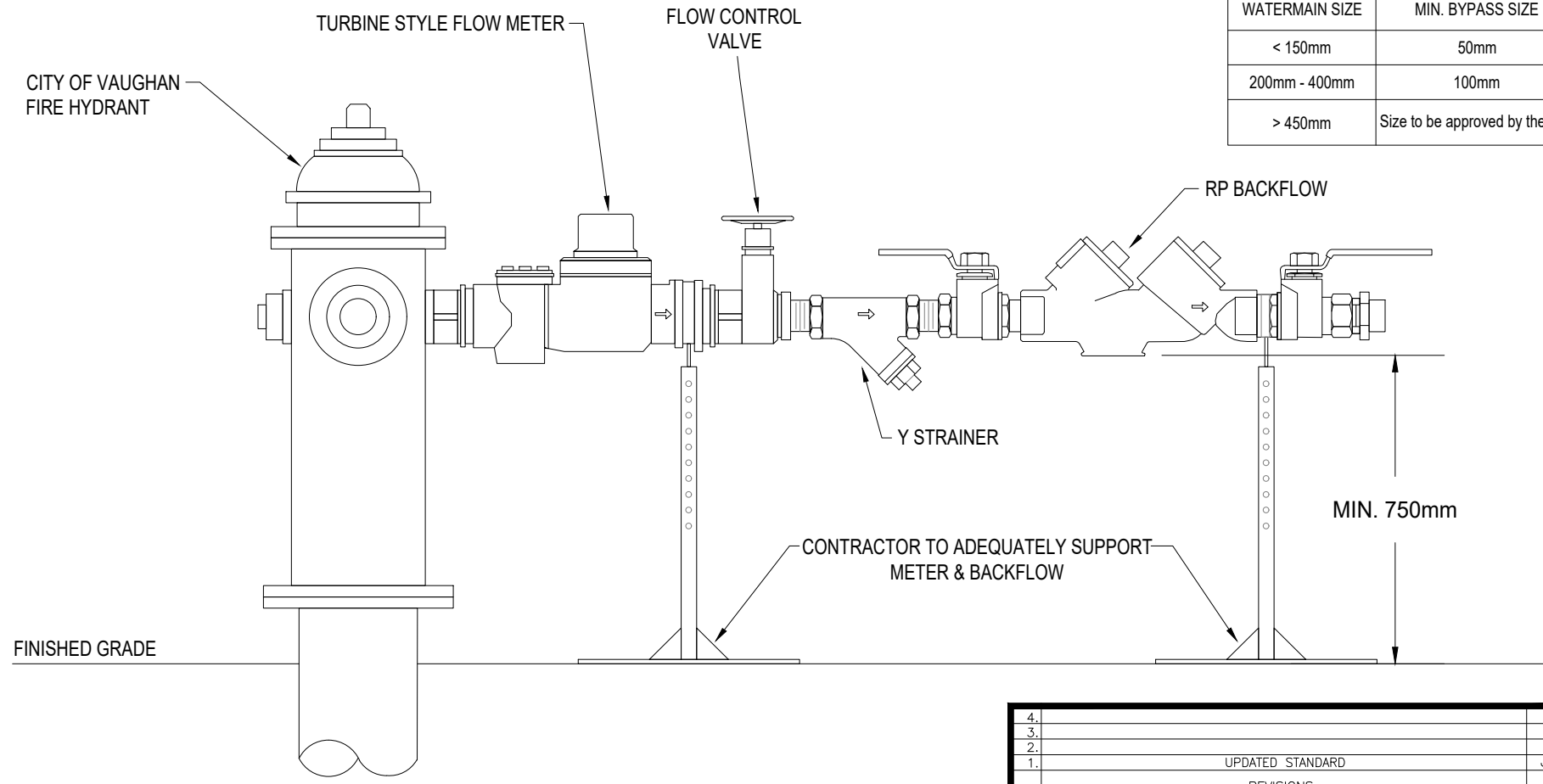

- NOTES:**
- BACKFLOW DEVICE MUST BE A REDUCED PRESSURE PRINCIPLE ASSEMBLY (RP) AND IN CONFORMITY WITH CSA B64.10. BACKFLOW TO BE SUPPLIED AND TESTED BY APPLICANT.
  - BACKFLOW TO BE FIELD TESTED BY A CROSS-CONNECTION CONTROL SPECIALIST WITH VALID OWWA TESTER CERTIFICATE. CITY OF VAUGHAN OPERATOR TO WITNESS ALL FIELD TESTING OF THE BACKFLOW ASSEMBLY. BACKFLOW MUST BE RE-TESTED WHEN RELOCATED, REPAIRED OR REPLACED.
  - BACKFLOW DEVICE TO BE DISCONNECTED FROM BYPASS PIPING DURING WATERMAIN PRESSURE TESTS.
  - ONLY CITY OF VAUGHAN STAFF TO OPERATE HYDRANT & MUNICIPALITY OWNED VALVES. APPLICANT/CONTRACTOR ARE NOT PERMITTED TO TURN HYDRANT ON/OFF.
  - APPLICANT/CONTRACTOR TO BE RESPONSIBLE FOR ANY DAMAGE TO CITY OF VAUGHAN AND/OR PRIVATE PROPERTY.
  - FREEZING PROTECTION MUST ME PROVIDED AND INSTALLED BY THE APPLICANT WHEN APPLICABLE.

**mm** DIMENSIONS IN MILLIMETRES EXCEPT AS NOTED

4.		
3.		
2.		
1.	UPDATED STANDARD	JAN. 21
	REVISIONS	DATE



**CITY OF VAUGHAN ENGINEERING STANDARD**

**FIRE HYDRANT CONNECTION WITH METER AND BACK FLOW PREVENTER**

NOT TO SCALE      DESIGNED: DEPT. ENG.      STD. DWG.  
 REVISION: 01      DATE: JAN. 2021      **W - 114**

Acad. File: C:\Infrastructure\Delivery\Infrastructure Programming\VAO\City Standards\Design Criteria 2020\City Standards Update - Water\Water Standards\W-118 - Auto Irrigation Sys - 18.dwg

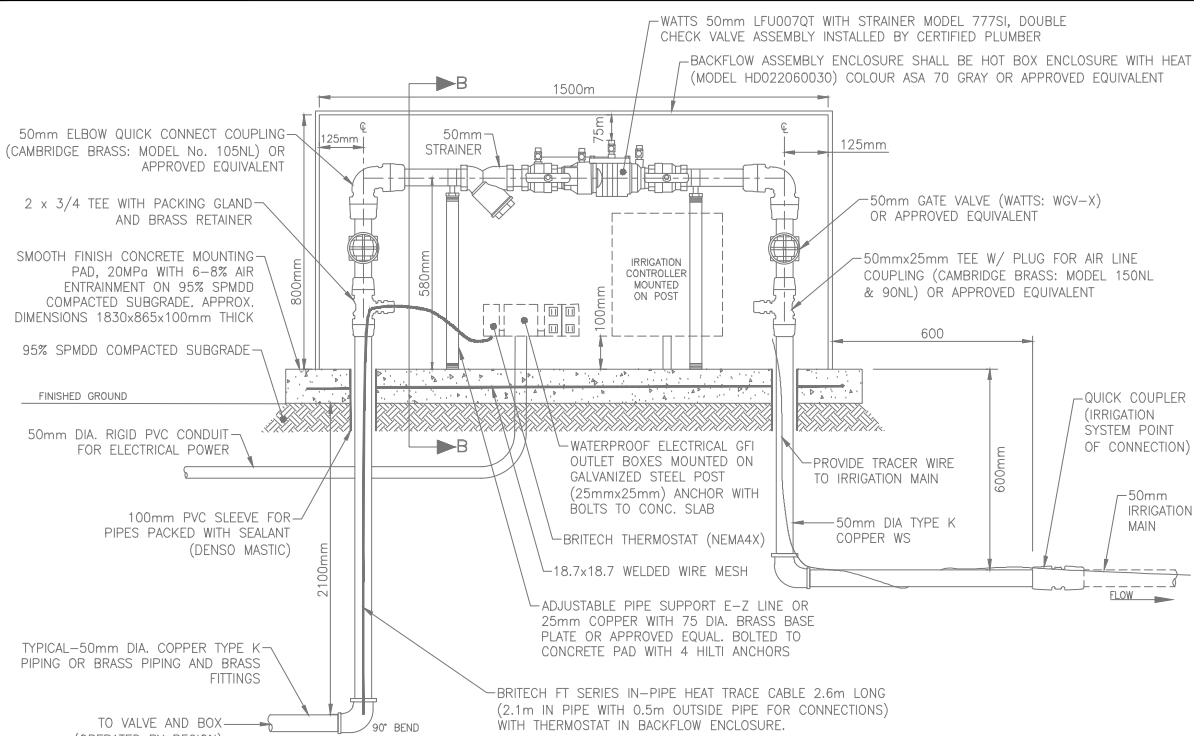

**BACKFLOW PROTECTION ASSEMBLY**  
OWNED BY YORK REGION

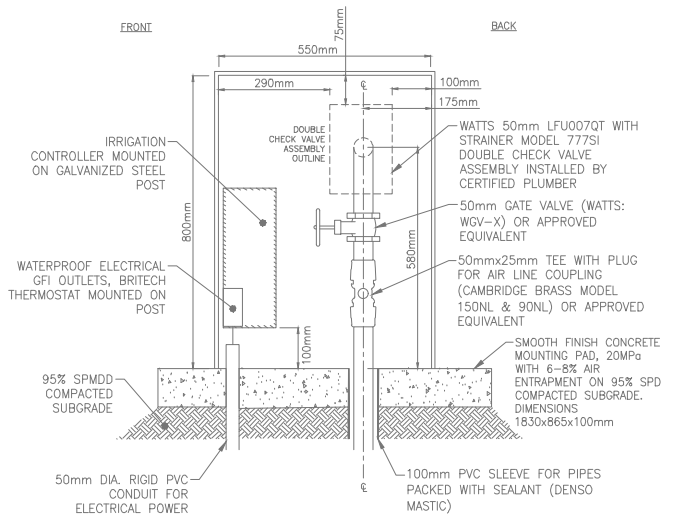

**SECTION 'B - B'**  
**BACKFLOW PROTECTION ASSEMBLY**

**NOTES**

- 24LB ANODE COVERING AN AREA OF 150 LINEAR FEET TO BE INSTALLED FOR SERVICE PROTECTION, MIDPOINT ON LENGTH OF PIPE FROM WM TO CITY'S GATE VALVE.
- SERVICE TO BE TURNED ON AND PRESSURE TESTED PRIOR TO BACKFILLING.

**mm** DIMENSIONS IN MILLIMETRES EXCEPT AS NOTED

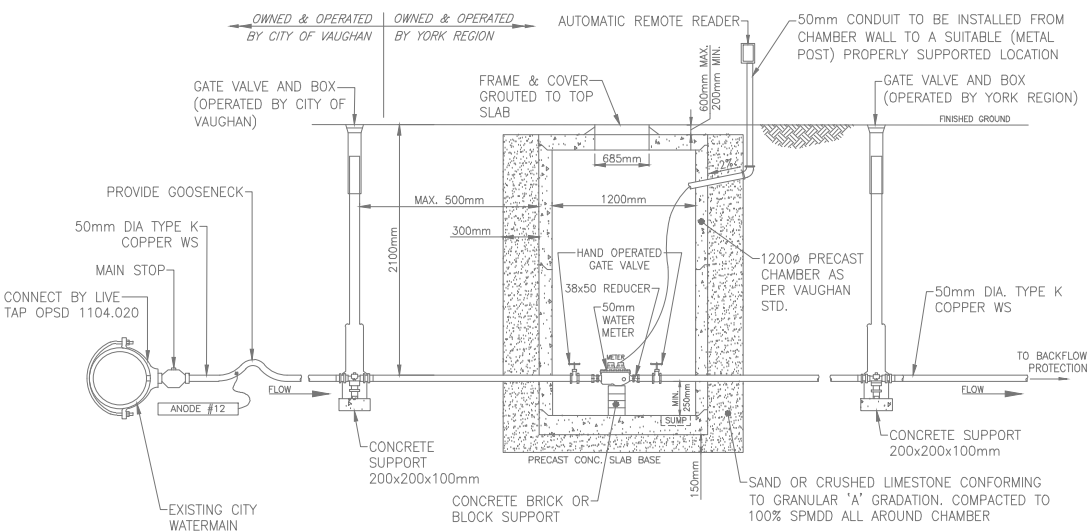

**WATER METER CHAMBER ARRANGEMENT**  
OWNED BY YORK REGION

5.		
4.		
3.		
2.		
1.		
REVISIONS		DATE



**CITY OF VAUGHAN ENGINEERING STANDARD**  
**AUTOMATED IRRIGATION SYSTEM**  
**FOR YORK REGION LANDSCAPE MEDIANS**

NOT TO SCALE      DESIGNED: \_\_\_\_\_      STD. DWG.  
 REVISION: \_\_\_\_\_      DATE: \_\_\_\_\_ DEC. 2022      **W-118**

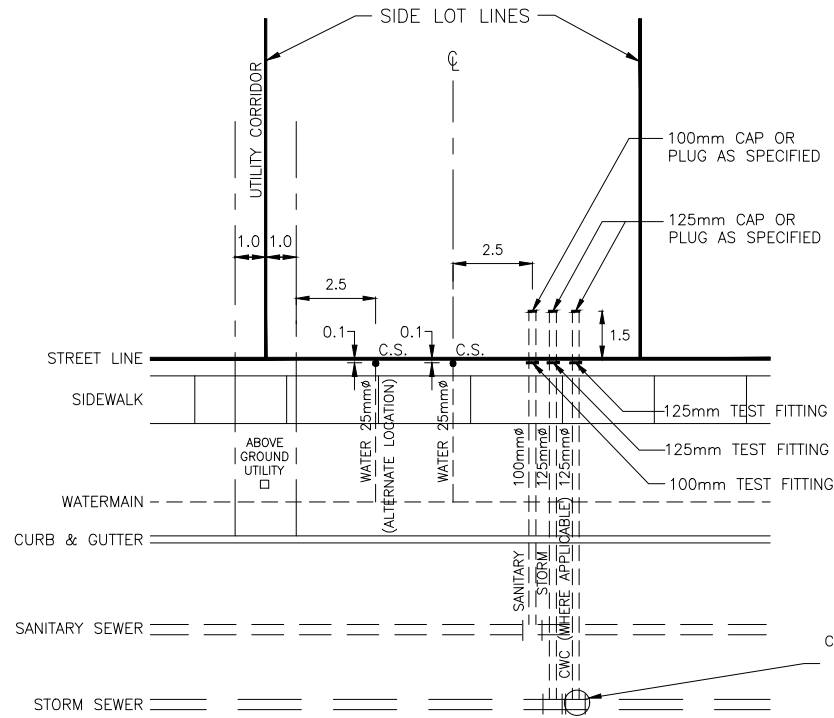

### SINGLE SEWER & SINGLE WATER SERVICE

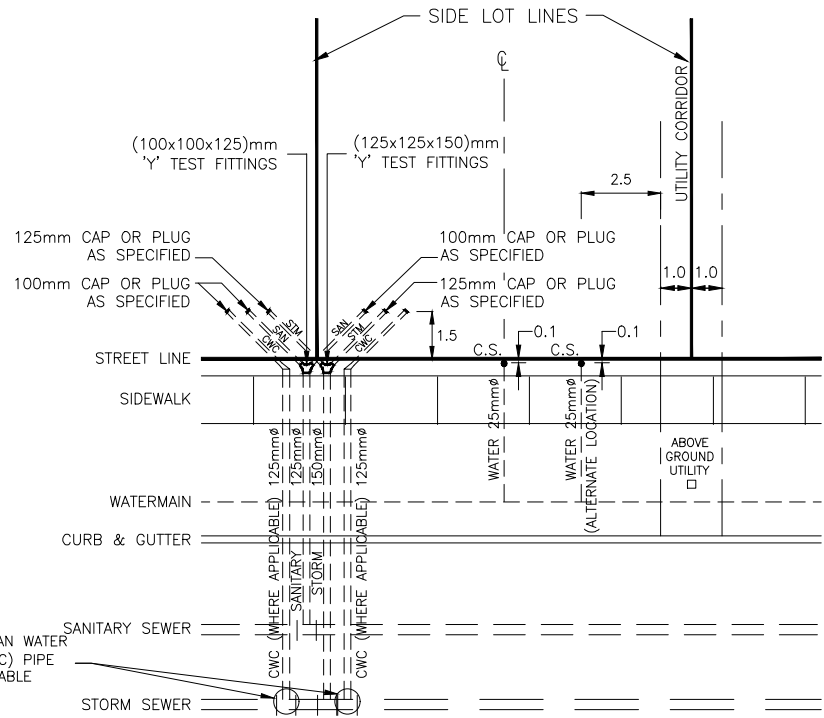

### SINGLE WATER & DOUBLE SEWER SERVICE

**NOTES**

1. RESIDENTIAL DWELLING SHALL BE SERVICED WITH A MINIMUM 25mm (1") WATER SERVICE CONNECTION. DWELLING STRUCTURES THAT HAVE SPRINKLER SYSTEM AND/OR HIGH HYDRAULIC LOADS AND REQUIRE WATER SERVICE CONNECTION LARGER THAN 25mm (1") SHALL BE SUBJECT TO THE CITY'S APPROVAL.
2. WATER SERVICE CONNECTIONS AND CURB STOPS SHALL BE AS DETAILED ON O.P.S.D. 1104.010 OR 1104.020.
3. SANITARY AND STORM SERVICE CONNECTIONS SHALL BE AS PER O.P.S.D. 1006.010 OR 1006.020 EXCEPT THAT THE CONNECTIONS SHALL EXTEND 1.5m BEYOND THE PROPERTY LINE AND SHALL BE PLUGGED OR CAPPED AT THAT POINT.
4. ALL PVC SANITARY LATERAL PIPE SHALL BE GREEN IN COLOUR.
5. SANITARY TEST FITTINGS SHALL BE LETTERED 'SAN'. FITTINGS AND PLUGS SHALL BE AS PER CITY REQUIREMENTS.
6. ALL PVC STORM LATERAL PIPE SHALL BE WHITE IN COLOUR.
7. STORM TEST FITTING SHALL BE LETTERED 'STM'. FITTINGS AND PLUGS SHALL BE AS PER CITY REQUIREMENTS.
8. MARKERS SHALL BE PLACED AT ENDS OF 'SAN' AND 'STM' CONNECTIONS.
9. WATER SERVICE CURB STOP SHALL BE LOCATED IN THE GRASSED AREA OF THE R.O.W. ANY OTHER LOCATION SHALL BE SUBJECT TO THE CITY'S APPROVAL.
10. CWC SERVICE WITHIN LOT NOT TO BE INSTALLED UNTIL ROOF LEADERS ARE INSTALLED.
11. HOUSE ROOF LEADERS TO DISCHARGE A MINIMUM OF 1.5m FROM ALL BUILDINGS TO GROUND SURFACE BY MEANS OF A SPLASH PAD WHERE CWC ARE NOT AVAILABLE.

**LEGEND**

CWC - CLEAN WATER COLLECTOR

**m** DIMENSIONS IN METRES  
EXCEPT AS NOTED

4.		
3.		
2.		
1.		
REVISIONS		DATE



CITY OF VAUGHAN ENGINEERING STANDARD

## RESIDENTIAL SERVICE CONNECTIONS

NOT TO SCALE      DESIGNED: \_\_\_\_\_      STD. DWG.  
 REVISION: \_\_\_\_\_      DATE: DEC. 2020      **C - 101**

FILE: C:\Infrastructure\Delivery\Infrastructure Programming\PMO\City Standards\Design Criteria\2020-21\City Standards Update\Folder\Co\StandardDrawings\_CAD\_2021\C-102 - Block Service Connections.dwg

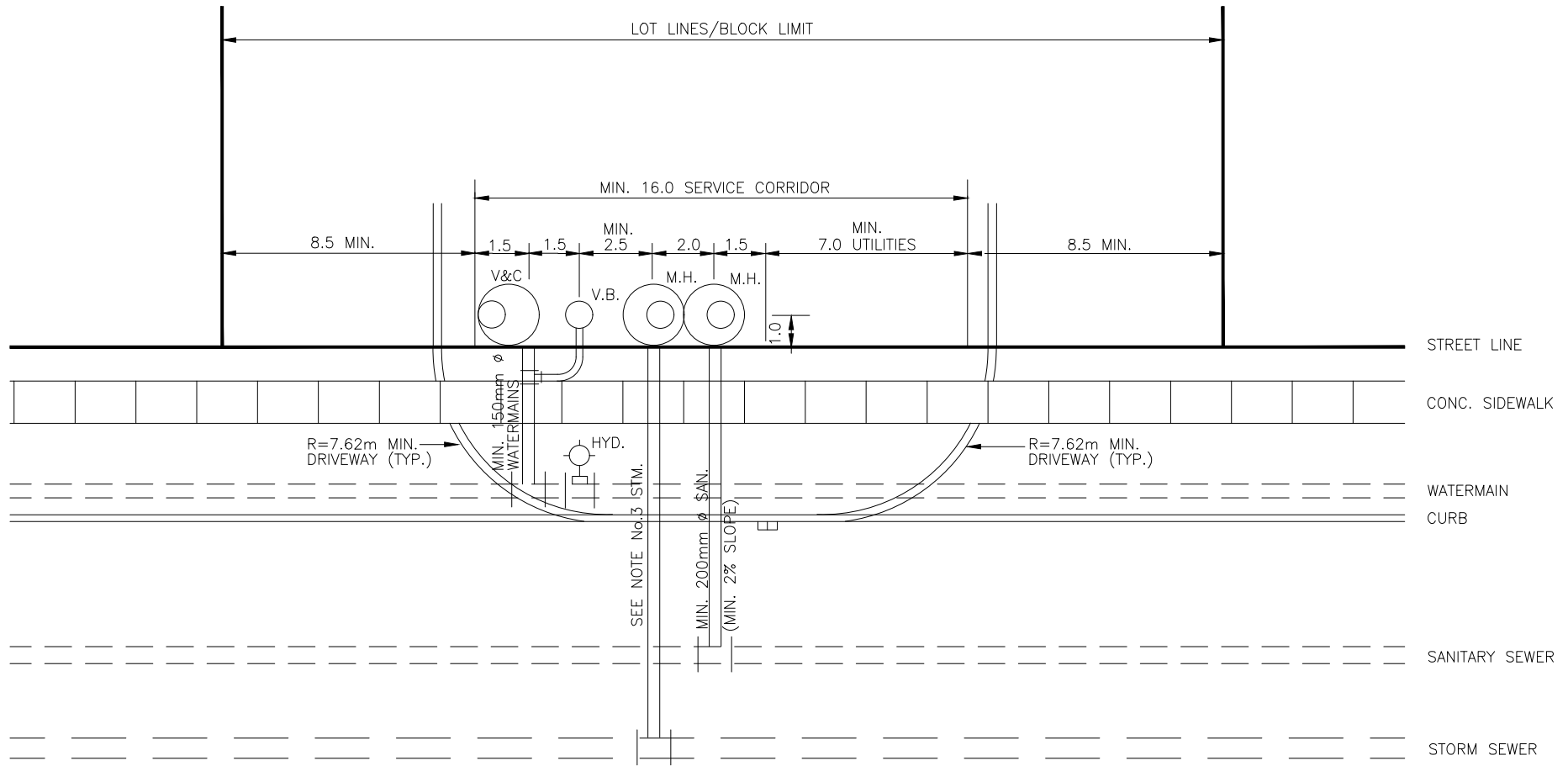

NOTES

1. ABOVE GROUND UTILITIES TO BE LOCATED MINIMUM 1.0m FROM CURBS, SIDEWALK AND DRIVEWAYS.
2. MAINTENANCE HOLES AND VALVE CHAMBERS FOR SERVICE CONNECTIONS TO BE LOCATED AT 1.0m OFF STREET LINE ON PRIVATE PROPERTY.
3. STORM SEWER CONNECTIONS SHALL BE SIZED BASED UPON STORM WATER MANAGEMENT REQUIREMENTS. SEE STD. C-104.
4. WATER SERVICE CONNECTIONS SHALL BE AS DETAILED ON STANDARD DRAWING C-103.
5. CB TO BE LOCATED WITHIN SERVICE CORRIDOR.

4.		
3.		
2.		
1.		
REVISIONS		DATE



CITY OF VAUGHAN ENGINEERING STANDARD

**BLOCK SERVICE CONNECTIONS**

**m** DIMENSIONS IN METRES  
EXCEPT AS NOTED

NOT TO SCALE      DESIGNED: \_\_\_\_\_  
REVISION: \_\_\_\_\_      DATE: DEC. 2020

STD. DWG.  
**C - 102**

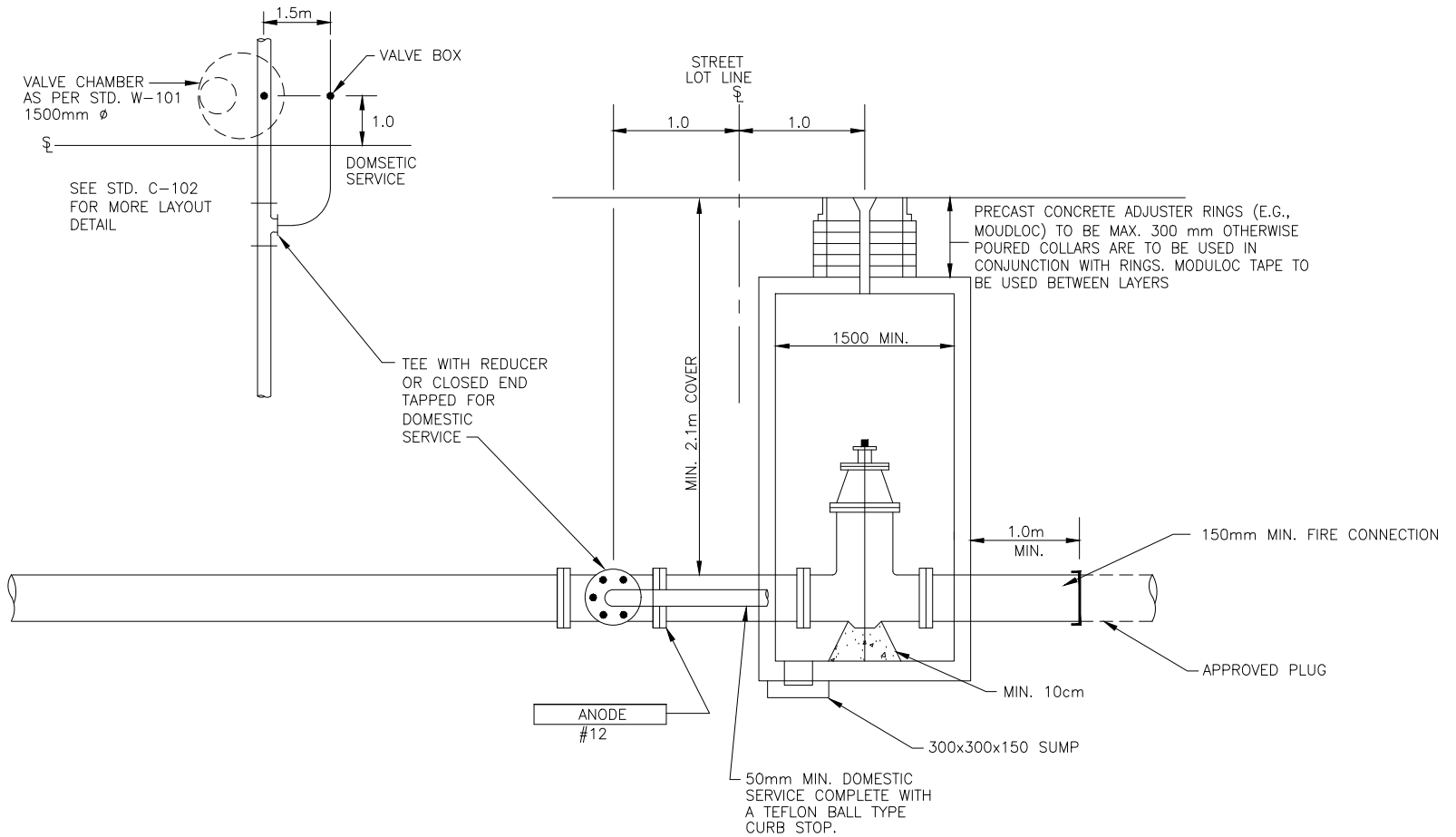

**NOTES**

1. BOND BREAKER TO BE USED BETWEEN ALL CONCRETE AND FITTINGS.
2. PROVIDE RESTRAINED MECHANICAL JOINTS OR SLIP-ON JOINTS WITH TIE RODS & CLAMPS AS REQUIRED.
3. THRUST BLOCKS SHALL NOT BE USED WITHIN VALVE CHAMBER.
4. THRUST BLOCKS SHALL NOT BE USED ON PVC WATERMANS.

4.		
3.		
2.		
1.		
REVISIONS		DATE



CITY OF VAUGHAN ENGINEERING STANDARD

**BLOCK WATER CONNECTION**

**m** DIMENSIONS IN METRES EXCEPT AS NOTED

NOT TO SCALE DESIGNED: \_\_\_\_\_

REVISION: \_\_\_\_\_ DATE: DEC. 2020

STD. DWG.

**C - 103**

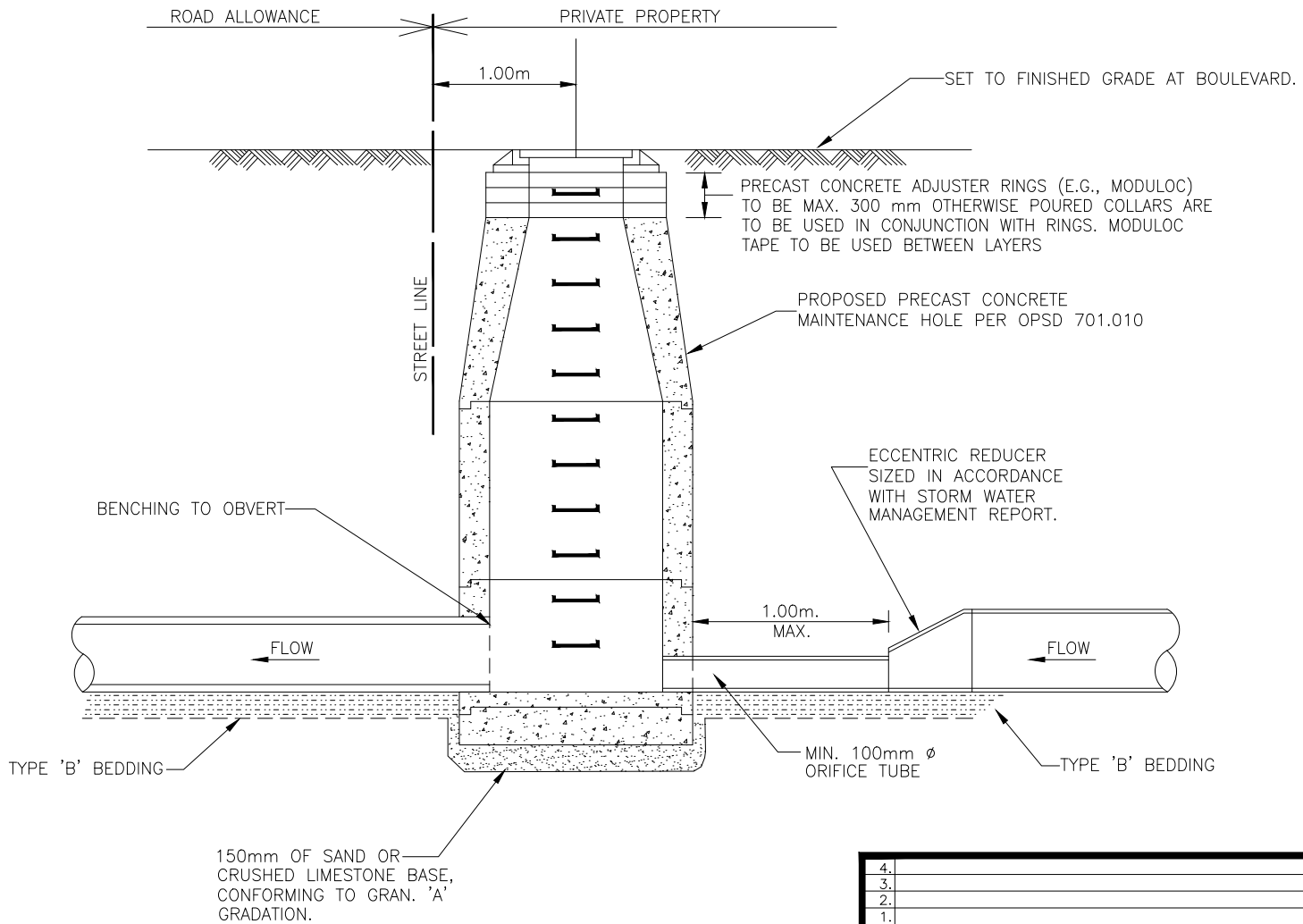

NOTE

1. CAST IRON INTEGRATED FRAMES ARE ACCEPTABLE

4.		
3.		
2.		
1.		
REVISIONS		DATE



CITY OF VAUGHAN ENGINEERING STANDARD

**STORM CONNECTIONS  
WITH ORIFICE CONTROL**

NOT TO SCALE      DESIGNED: \_\_\_\_\_

REVISION: \_\_\_\_\_      DATE: DEC. 2020

STD. DWG.

**C - 104**

**m** DIMENSIONS IN METRES  
EXCEPT AS NOTED

Acad File: C:\Infrastructure Delivery\Infrastructure Programs\IMD\City Standards Update Folder\CivilStandards\SL-100a - Standard Trench for Direct Buried Cables.dwg

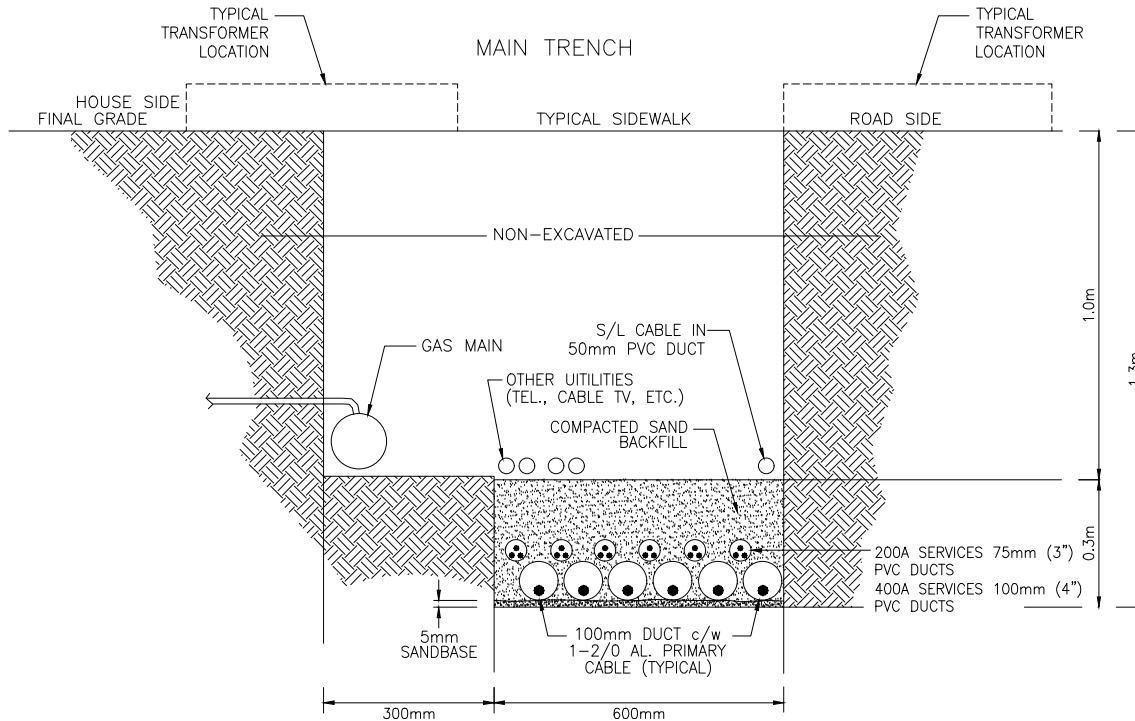

**mm** DIMENSIONS IN MILLIMETRES  
EXCEPT AS NOTED

**NOTES:**

1. 100mm P.V.C. TYPE II DUCT REQUIRED UNDER PAVED AREAS.  
CAPACITY PER DUCT:  
A) 1-PRIMARY CABLE - 100mm (4")  
B) 2-SECONDARY CABLES [200A-75mm(3") /400A-100mm (4")]
2. 1 SPARE DUCT IS REQUIRED AT EACH CROSSING - 100mm (4")
3. INSTALL PATIO SLABS AT ALL HYDRANT & V.C. LOCATIONS

4.		
3.		
2.		
1.		
	REVISIONS	DATE



CITY OF VAUGHAN ENGINEERING STANDARD

**STANDARD TRENCH  
FOR DIRECT BURIED CABLES**

NOT TO SCALE      DESIGNED: \_\_\_\_\_      STD. DWG.  
REVISION: \_\_\_\_\_      DATE: 2022      **SL - 100a**



Acad File: C:\Infrastructure Delivery\Infrastructure Programs\IMD\City Standards\Update Folder\CivilStandards\SL-100b - Standard Streetlighting Trench.dwg

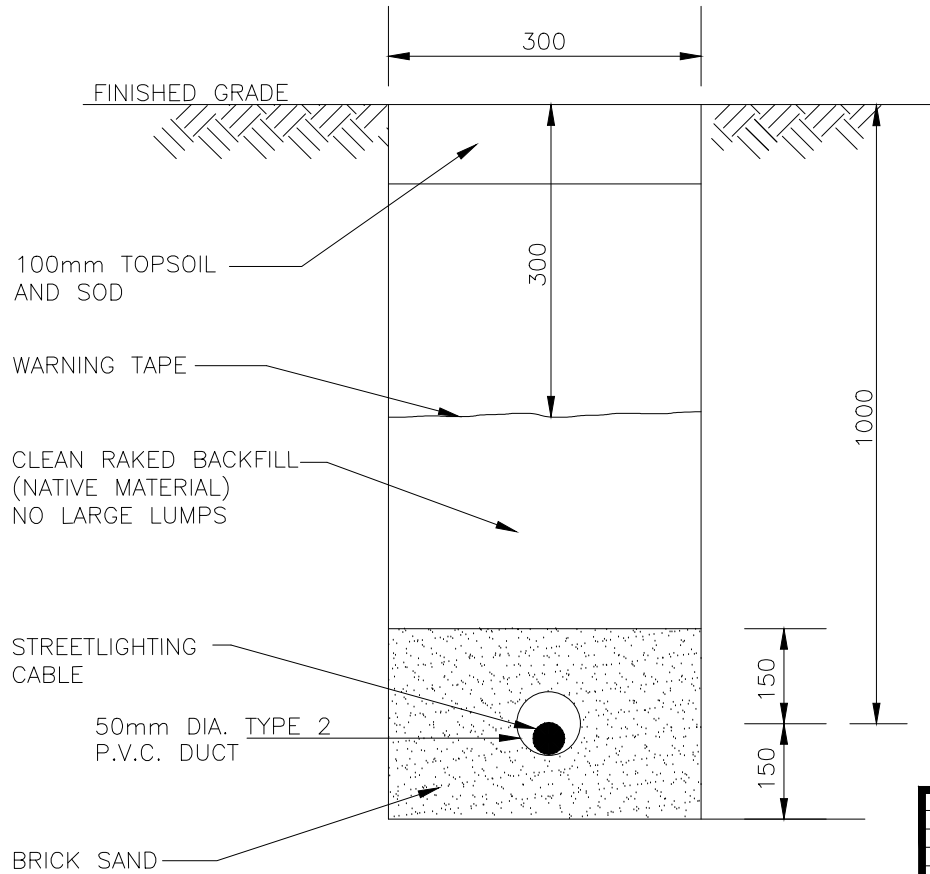

**mm** DIMENSIONS IN MILLIMETRES  
 EXCEPT AS NOTED

4.		
3.		
2.		
1.		
REVISIONS		DATE



CITY OF VAUGHAN ENGINEERING STANDARD

## STANDARD STREETLIGHTING TRENCH

NOT TO SCALE      DESIGNED: \_\_\_\_\_  
 REVISION: \_\_\_\_\_      DATE: 2022

STD. DWG.  
**SL - 100b**

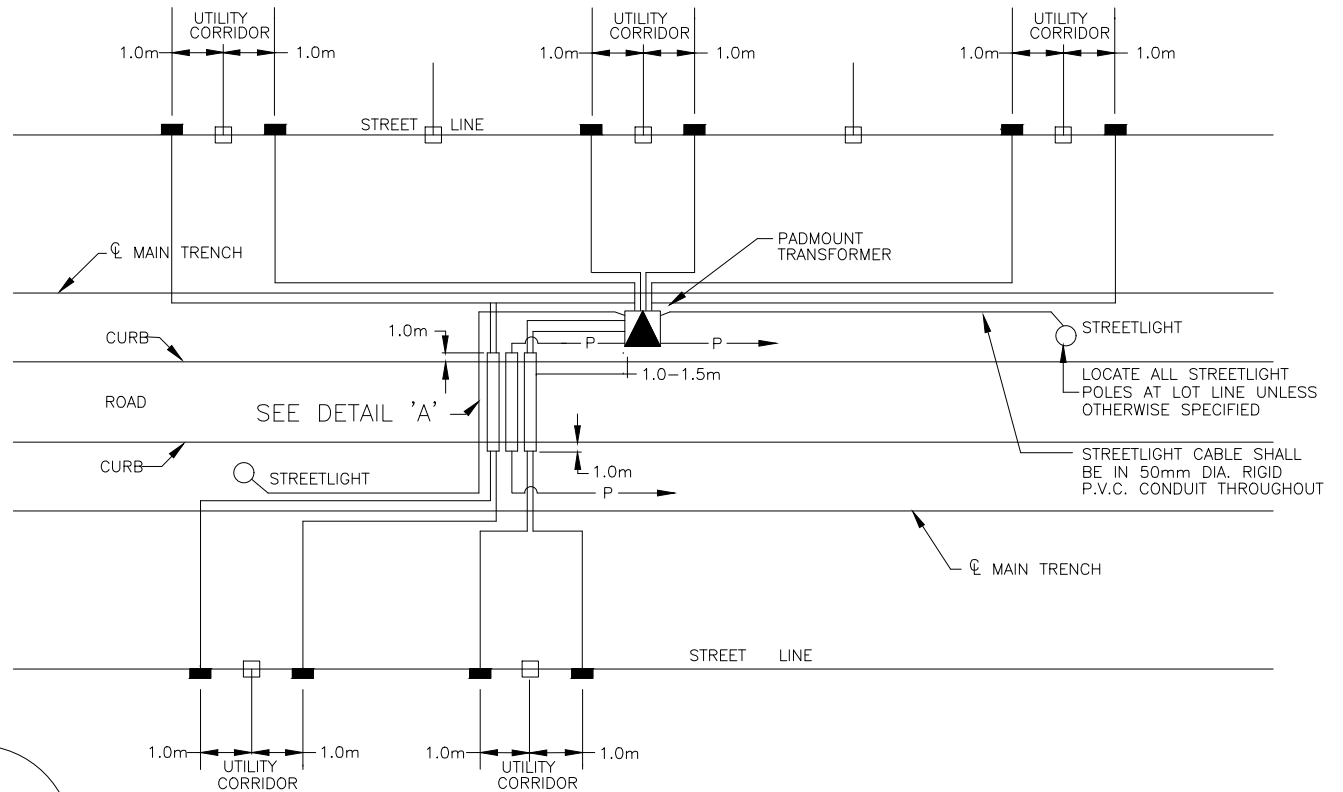

SEE DETAIL 'A'

LOCATE ALL STREETLIGHT POLES AT LOT LINE UNLESS OTHERWISE SPECIFIED

STREETLIGHT CABLE SHALL BE IN 50mm DIA. RIGID P.V.C. CONDUIT THROUGHOUT

### DETAIL 'A'

#### TYPICAL DUCT ARRANGEMENT FOR DIRECT BURIED ROAD CROSSING DUCTS

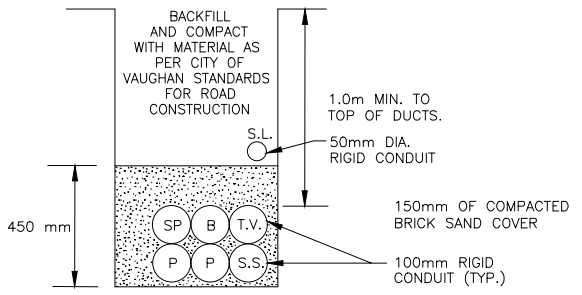

#### DUCTS

- B - BELL CABLE
- T.V. - CABLE TELEVISION
- P - PRIMARY CABLE (1-PER DUCT)
- S.S. - SECONDARY SERVICE (MAX. -2 RUNS PER DUCT)
- S.L. - STREETLIGHT CABLE CONDUIT
- SP - SPARE CONDUIT

4.		
3.		
2.		
1.		
REVISIONS		DATE



CITY OF VAUGHAN ENGINEERING STANDARD

## INSTALLATION OF STREETLIGHT CABLE AT ROAD CROSSINGS

NOT TO SCALE      DESIGNED: \_\_\_\_\_  
 REVISION: \_\_\_\_\_      DATE: 2022

STD. DWG.  
 SL - 101

Acad File: C:\Users\vaughan\OneDrive - City of Vaughan\My Documents\Map Rev\2022\1 - Reg. Services - Map Rev\2022\1 - Reg. - 01mm\01c - Standard\Standard\STREETLIGHT STANDARDS - NEW\01c-102 - Streetlight Wiring Connections.dwg

**NOTES**

1. ONLY ONE STREETLIGHT BREAKER REQUIRED AT STREET LIGHT PEDESTAL.
2. PEDESTAL FEED SHALL BE FUSED AT TRANSFORMER.
3. STREETLIGHT FEED TO BE FUSED AT PEDESTAL.
4. STREETLIGHT TO BE FUSED IN HAND WELL.
4. INSULATE SPLIT BOLTS AS PER NOTES BELOW.

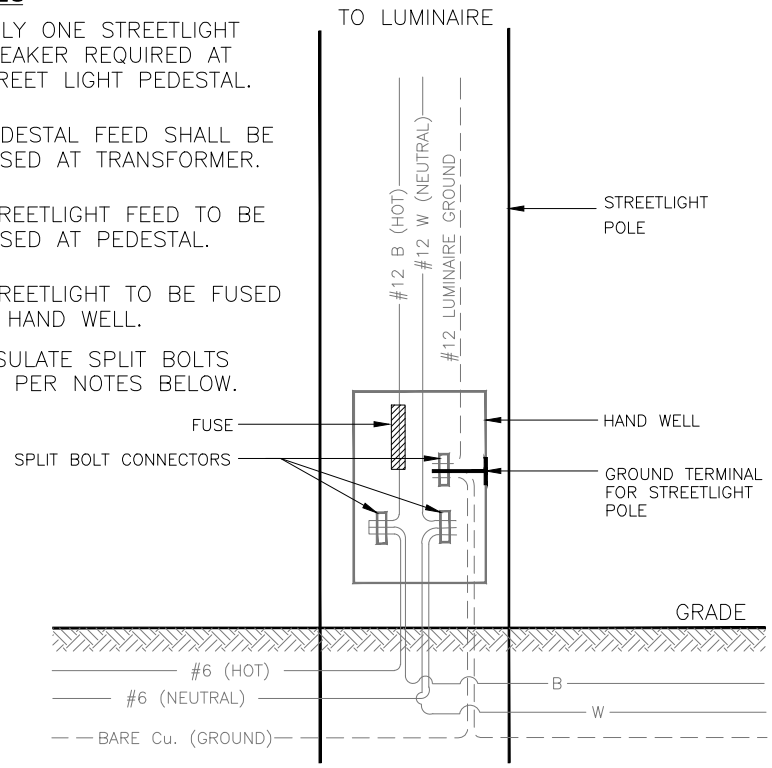

120V OR 347V STREETLIGHT CONNECTION

**NOTES:**

1. SPLIT BOLTS ARE TO BE USED ABOVE GRADE ONLY.
2. SPLIT BOLTS ARE TO BE COVERED USING SAP TAPE AND A FINAL COVERING OF SCOTCH 88.
3. FOR BELOW GRADE CONNECTIONS, A WATER STOP, NON-TENSION SLEEVE IS TO BE USED WITH A HEAT SHRINK PLACED OVER TOP.
4. ALL STREET LIGHT FURNITURE IS TO BE GROUNDED AS PER E.S.A. STANDARDS INCLUDING THE HEAD, POLE PEDESTAL.

**NOTES**

1. TWO STREETLIGHT BREAKERS REQUIRED AT STREET LIGHT PEDESTAL.
2. NO NEUTRAL IS REQUIRED.
3. INSULATE SPLIT BOLTS AS PER NOTES BELOW.

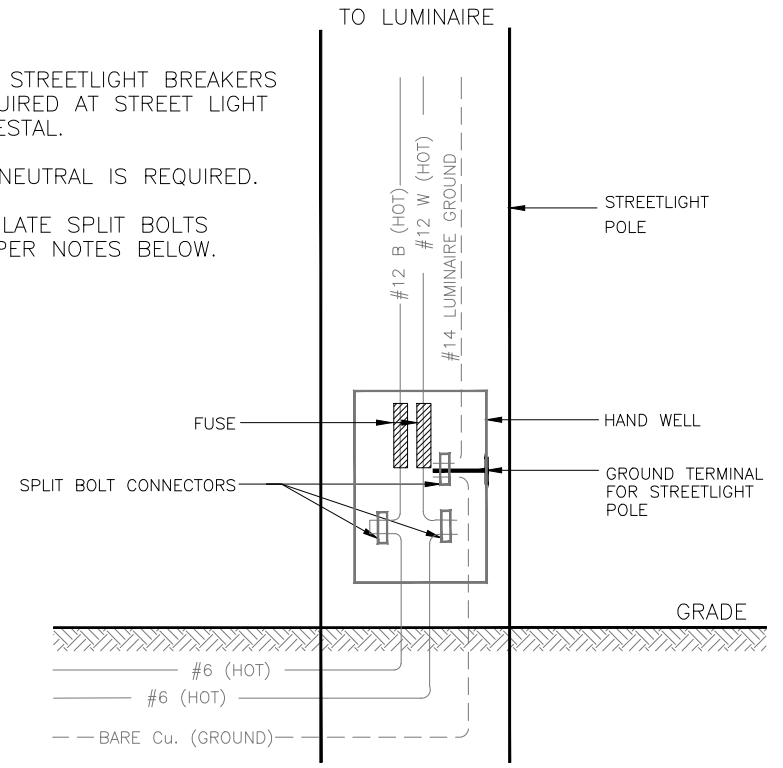

240V STREETLIGHT CONNECTION

4.		
3.		
2.		
1.		
REVISIONS		DATE



CITY OF VAUGHAN ENGINEERING STANDARD

**STREETLIGHT WIRING CONNECTIONS**

NOT TO SCALE      DESIGNED: \_\_\_\_\_  
 REVISION: \_\_\_\_\_      DATE: \_\_\_\_\_ 2022

STD. DWG.  
**SL - 102**

Acad File: C:\Users\vaughan\OneDrive - City of Vaughan\ - PP - Reg. - Consult - Drawings - In. Res. Services - Map - Rev 2022\ - Reg. - Other\City M.S.L. - Standardizing Standards\STREETLIGHT STANDARD - NIP.US - 103.dwg

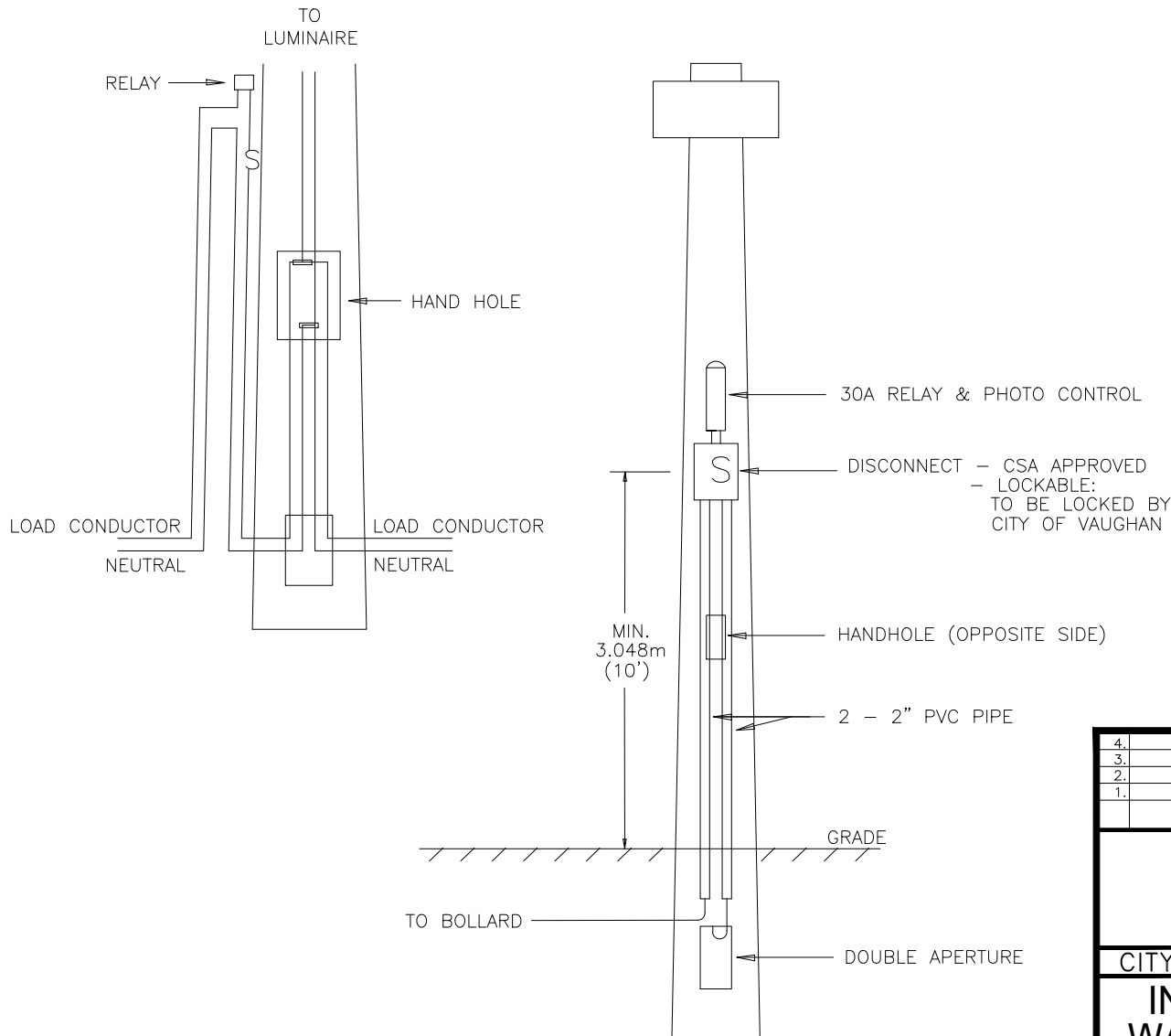

NOTES

1. INSTALL EQUIPMENT ON OPPOSITE SIDE TO HANDHOLE.
2. CONTRACTOR TO LEAVE ENOUGH CONDUCTOR TO MAKE CONNECTIONS.

4.		
3.		
2.		
1.		
REVISIONS		DATE



CITY OF VAUGHAN ENGINEERING STANDARD

**INSTALLATION OF BOLLARD  
WALKWAY LIGHT SERVICE AT  
STREETLIGHT POLE**

NOT TO SCALE	DESIGNED: _____	STD. DWG.
REVISION: _____	DATE: _____ 2022	<b>SL - 103</b>



Acad File: C:\Users\vaughan\OneDrive - City of Vaughan\3 - IP - Reg. - Detail Sheet\3 - IP - Reg. Services - Map Rev\2022\3 - IP - Reg. Services - Standard\Standard\STREETLIGHT STANDARDS - NEW\3-105 - S1 Pedestal Detailing

ORDER INFORMATION		
ITEM:	AMPS	QUANTITY
MAIN BREAKER SIZE		1
SINGLE POLE BREAKER		
2 POLE BREAKER		

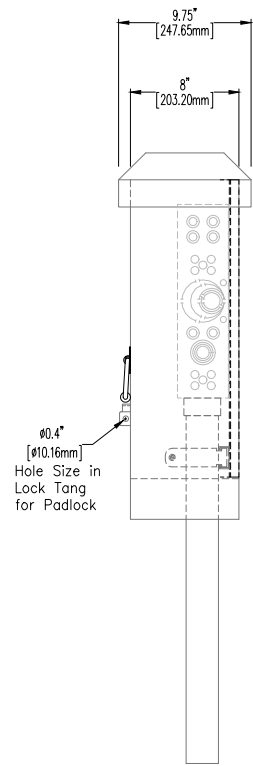

**RIGHT SIDE ELEVATION**

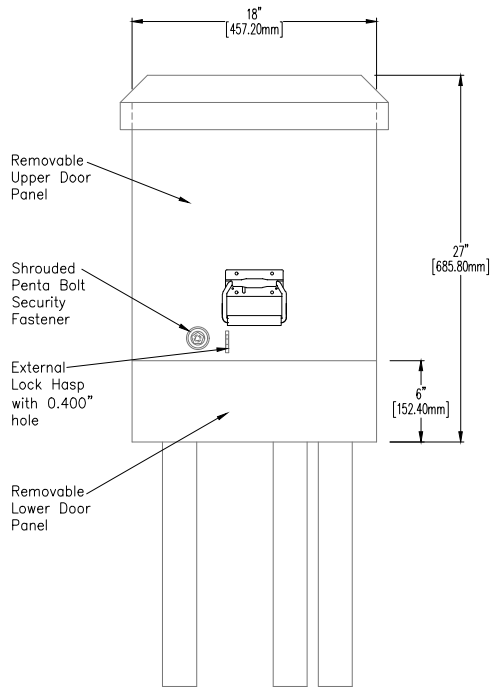

**FRONT ELEVATION  
WITH FRONT DOOR PANELS**

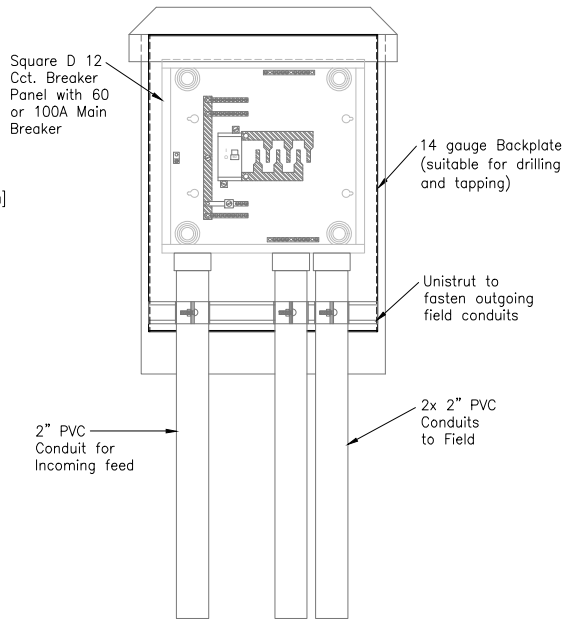

**FRONT ELEVATION  
FRONT DOOR PANELS REMOVED**

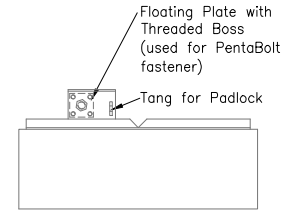

**LOWER PANEL  
(showing Pentabolt Assy and Lock Hasp)**

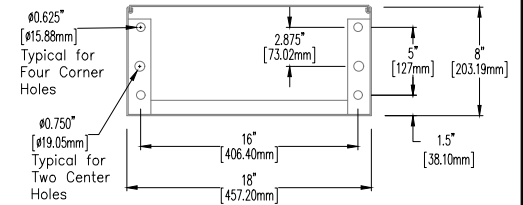

**BASE PLATE MOUNTING  
DIMENSIONS**

**NOTES**

1. PEDESTAL TO BE SUPPLIED WITH PENTA BOLT UNFASTENED.
2. PEDESTAL TO BE SUPPLIED WITHOUT A PENTA BOLT SOCKET WRENCH.
3. CITY OF VAUGHN SHALL SECURE THE PENTA BOLT ON PROJECT COMPLETION AND STREET LIGHTING ASSUMPTIONS BY THE CITY.

4.		
3.		
2.		
1.		
REVISIONS		DATE



CITY OF VAUGHAN ENGINEERING STANDARD

**STREETLIGHT PEDESTAL  
DETAIL**

NOT TO SCALE      DESIGNED: \_\_\_\_\_  
 REVISION: \_\_\_\_\_      DATE: \_\_\_\_\_ 2022

STD. DWG.  
**SL - 105**

Acad File: C:\Users\ludwiga\OneDrive - City of Vaughan\... - City of Vaughan\... - h. Reg. Service - Map 04/2022\... - Reg. - 0204/V/A SL - 106 SL-106.SL-106.dwg

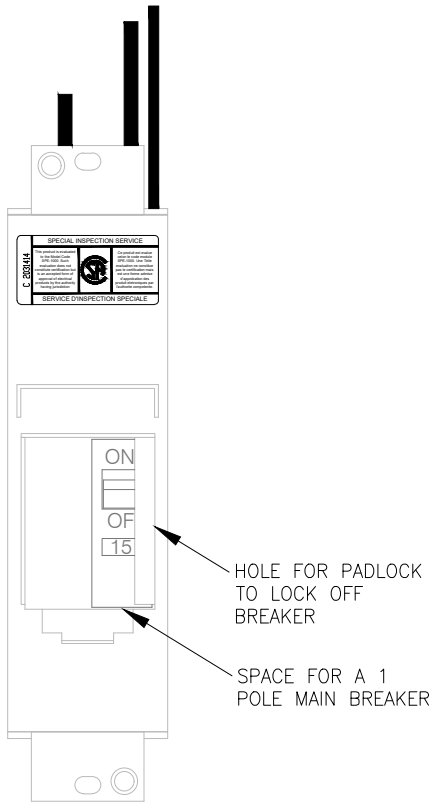

**FRONT ELEVATION**  
WITH LOCKING COVER  
PLATE REMOVED

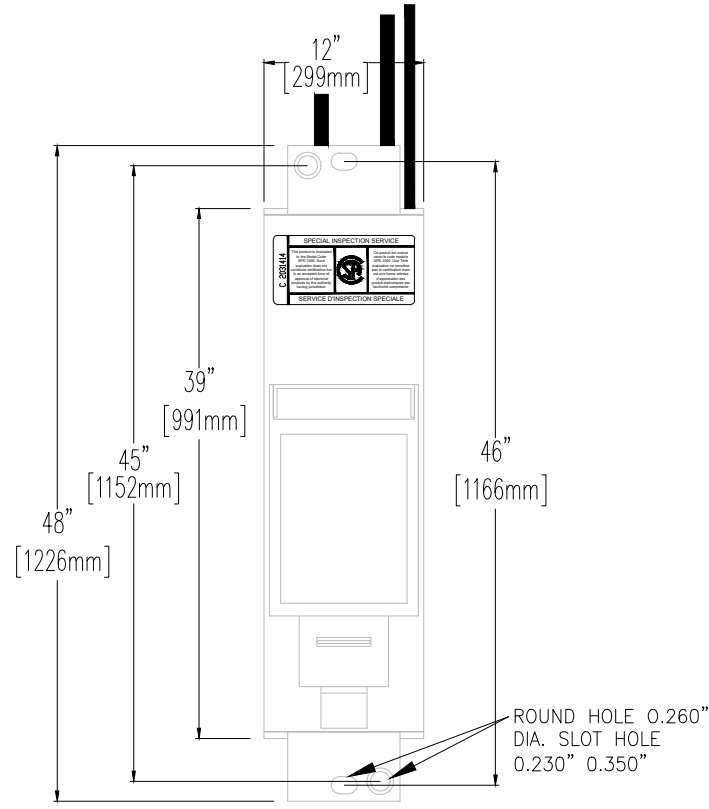

**FRONT ELEVATION**  
WITH LOCKING COVER IN PLACE

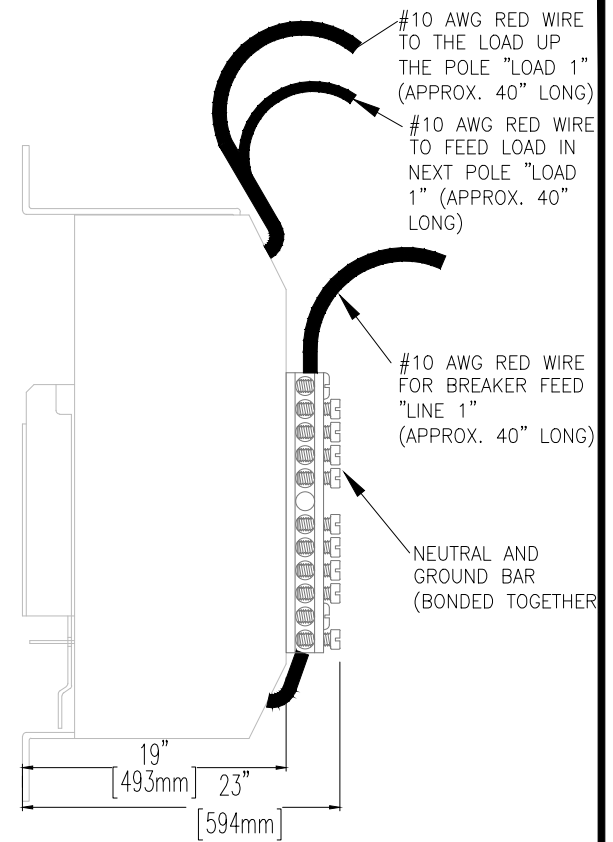

**SIDE ELEVATION**  
WITH LOCKING COVER IN PLACE

**MATERIAL NOTES:**

1. ENCLOSURE MAT'L: 14 GAUGE (0.083") THICK ZINC COATED (GALVANISED) SHEET METAL.
2. PAINT COLOR: ASA 61 GREY ELECTROSTATIC POWDER COAT FINISH
3. MAIN BREAKER: GE 15A, 2 POLE BREAKER
4. LOAD NEUTRAL LUGS: 9 LUGS NEUTRAL BAR, #4 AWG TO #14 AWG CAPACITY.
5. AS MANUFACTURED BY PSI OR EQUIVALENT.

4.		
3.		
2.		
1.		
	REVISIONS	DATE



CITY OF VAUGHAN ENGINEERING STANDARD

**POLE HAND HOLE BREAKER  
SL1-15**

NOT TO SCALE      DESIGNED: \_\_\_\_\_  
 REVISION: \_\_\_\_\_      DATE: \_\_\_\_\_ 2022

STD. DWG.  
**SL - 106**







Acad File: C:\Users\ludwiga\OneDrive - City of Vaughan\... - City of Vaughan\... - h. Reg. Service - Map 04/2022 - Reg. - 0204/V/A - Manufacturing Standards\STREETLIGHT STANDARDS - NEW\31-106\_SL-109\_SL-109.dwg

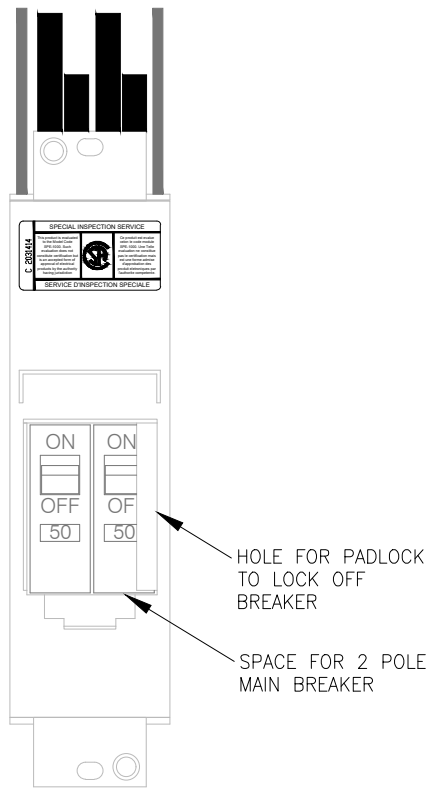

**FRONT ELEVATION**  
WITH LOCKING COVER  
PLATE REMOVED

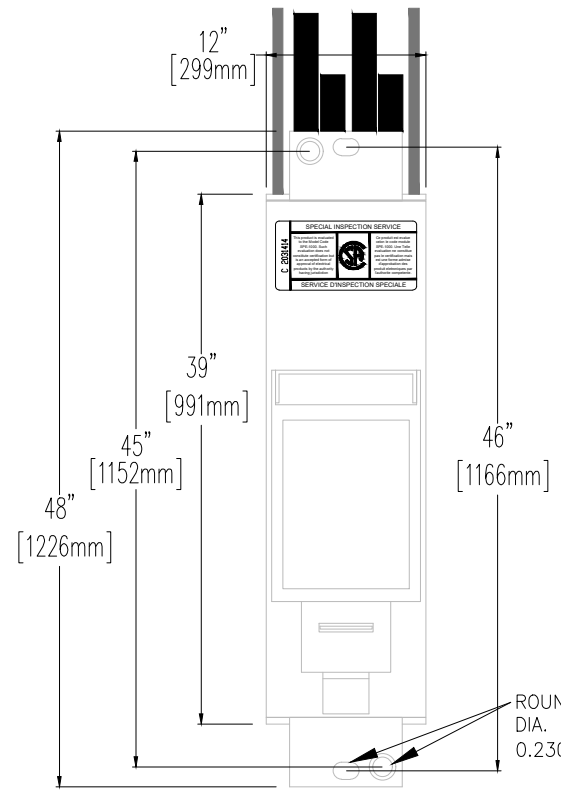

**FRONT ELEVATION**  
WITH LOCKING COVER IN PLACE

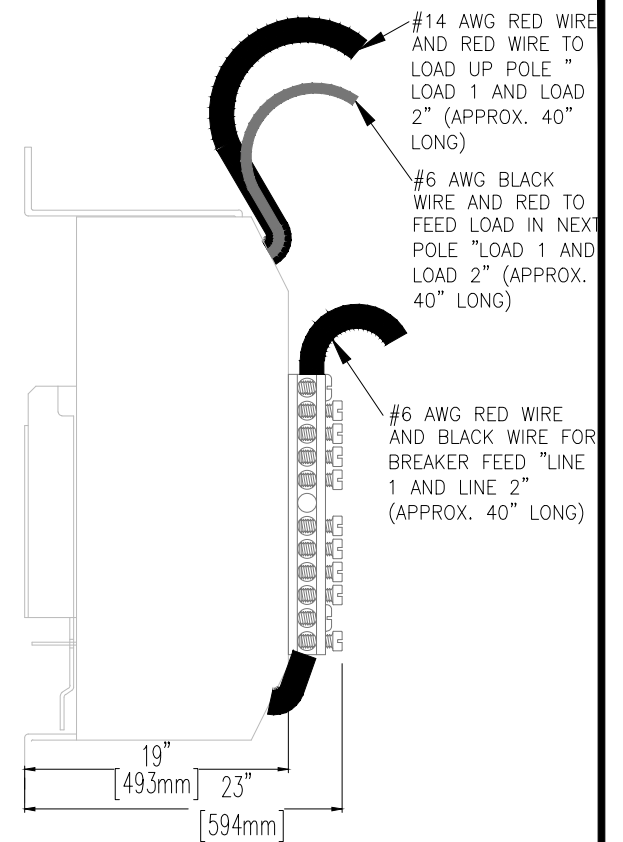

**SIDE ELEVATION**  
WITH LOCKING COVER IN PLACE

**MATERIAL NOTES:**

1. ENCLOSURE MAT'L: 14 GAUGE (0.083") THICK ZINC COATED (GALVANISED) SHEET METAL.
2. PAINT COLOR: ASA 61 GREY ELECTROSTATIC POWDER COAT FINISH
3. MAIN BREAKER: GE 15A, 2 POLE BREAKER
4. LOAD NEUTRAL LUGS: 9 LUGS NEUTRAL BAR, #4 AWG TO #14 AWG CAPACITY.
5. AS MANUFACTURED BY PSI OR EQUIVALENT.

4.		
3.		
2.		
1.		
REVISIONS		DATE



CITY OF VAUGHAN ENGINEERING STANDARD

**POLE HAND HOLE BREAKER  
SL2-50**

NOT TO SCALE      DESIGNED: \_\_\_\_\_  
 REVISION: \_\_\_\_\_      DATE: \_\_\_\_\_ 2022

STD. DWG.  
**SL - 109**

Acad File: C:\Users\vaughan\OneDrive - City of Vaughan\... - PE STAFF\... - In: Rev. Services - Mod: Rev\2022\... - Rev: 01m\01c\A\SL - Standard\Engineering Standards\STREETLIGHT STANDARDS - NEW\SL-110 - 5' Victorian Scroll Arm.dwg

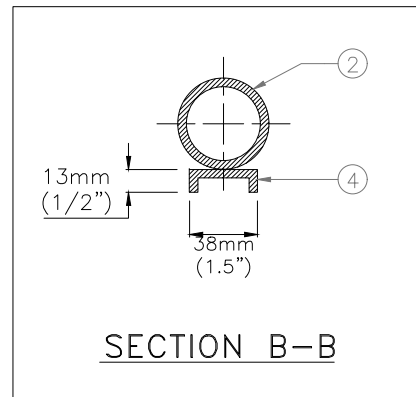
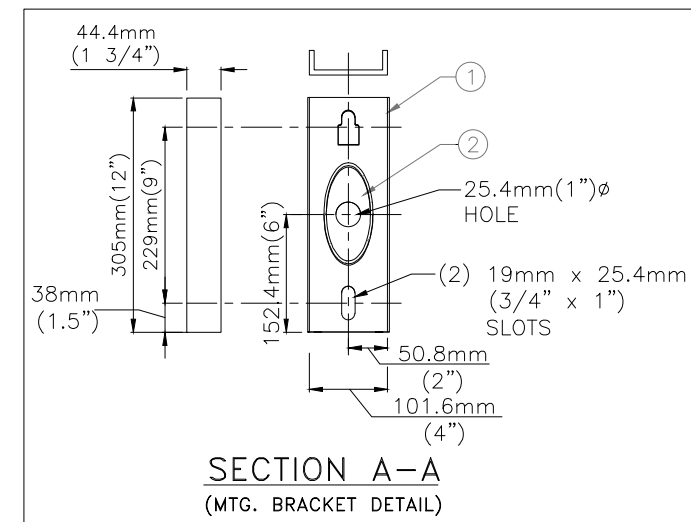
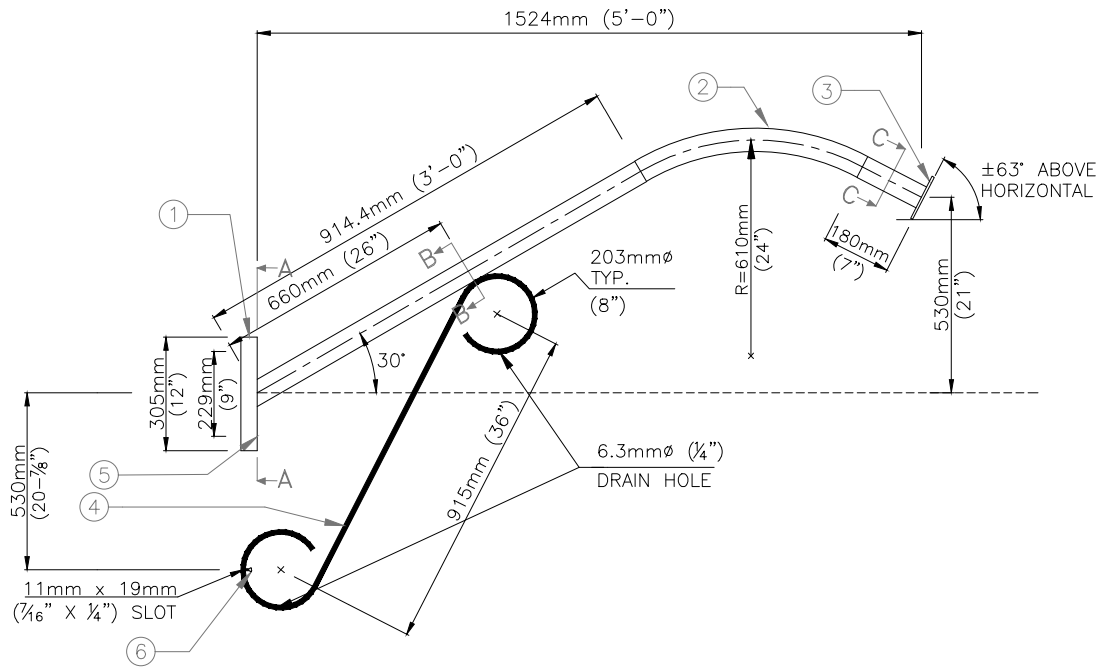

BILL OF MATERIAL			
ITEM #	PART DESCRIPTION	MATERIAL	QTY.
1	4" x 12" LONG CHANNEL	ALUM.	1
2	2.0" ALUMINUM PIPE	ALUM.	1
3	5" SQ. x 1/4" PLATE	ALUM.	1
4	1.5" CHANNEL	ALUM.	1
5	5/8" x 2.75" BOLTS & WASHERS	ST. STEEL	2
6	3/8" x 1.5" BOLT & WASHER	ST. STEEL	1

\* MAXIMUM LUMINAIRE SIZE ALLOWABLE  
50 lbs. - 3 sq.ft. EPA

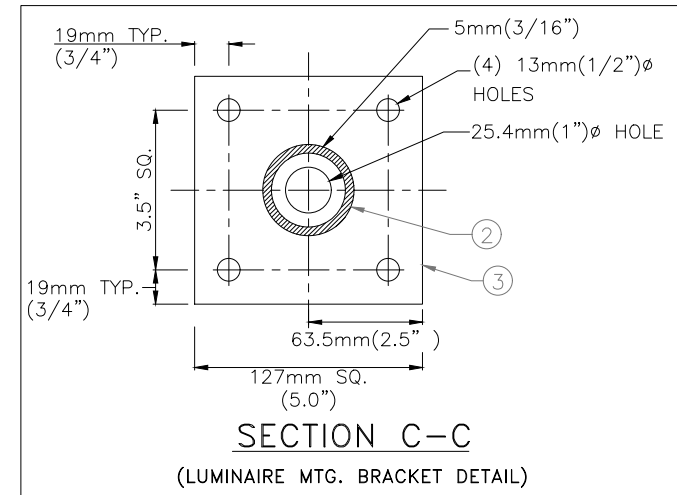

4.		
3.		
2.		
1.		
REVISIONS		DATE



CITY OF VAUGHAN ENGINEERING STANDARD

# 1.5m (5') VICTORIAN SCROLL ARM

NOT TO SCALE      DESIGNED: \_\_\_\_\_  
REVISION: \_\_\_\_\_      DATE: 2022

STD. DWG.  
SL - 110

**mm** DIMENSIONS IN MILLIMETRES  
EXCEPT AS NOTED

# VICTORIAN SCROLL ARM

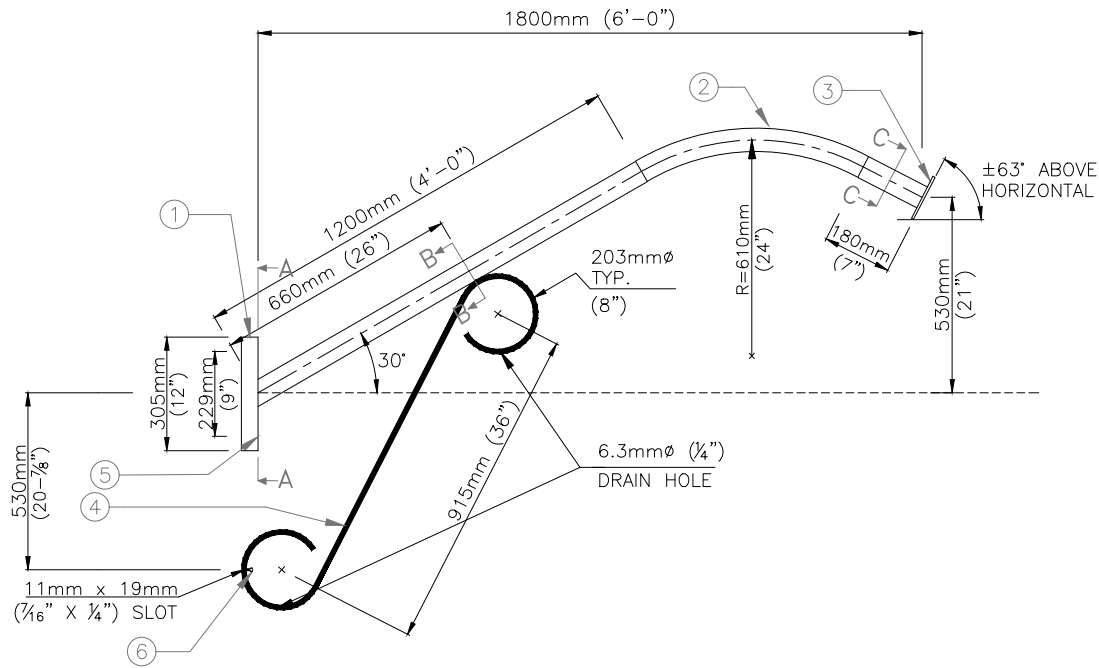

BILL OF MATERIAL			
ITEM #	PART DESCRIPTION	MATERIAL	QTY.
1	4" x 12" LONG CHANNEL	ALUM.	1
2	2.5" SCH. 40 ALUMINUM PIPE	ALUM.	1
3	5" SQ. x 1/4" PLATE	ALUM.	1
4	1.5" CHANNEL	ALUM.	1
5	5/8" x 2.75" BOLTS & WASHERS	ST. STEEL	2
6	3/8" x 1.5" BOLT & WASHER	ST. STEEL	1

\* MAXIMUM LUMINAIRE SIZE ALLOWABLE  
50 lbs. - 3 sq.ft. EPA

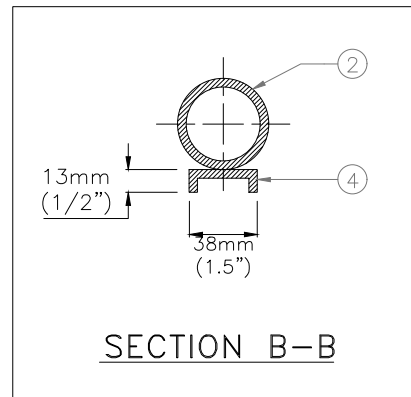
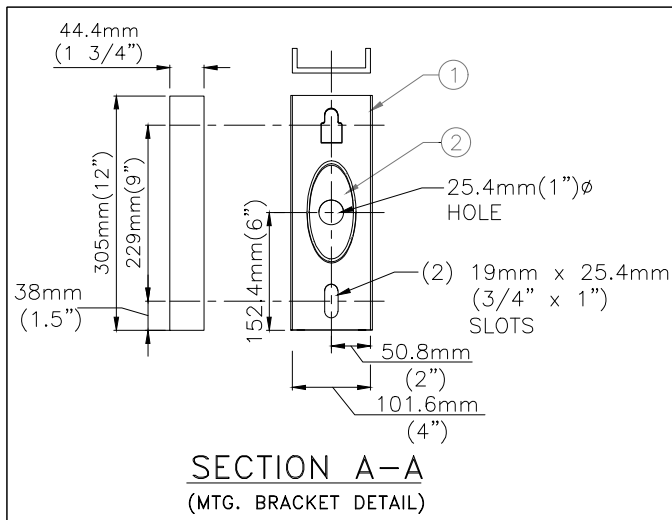
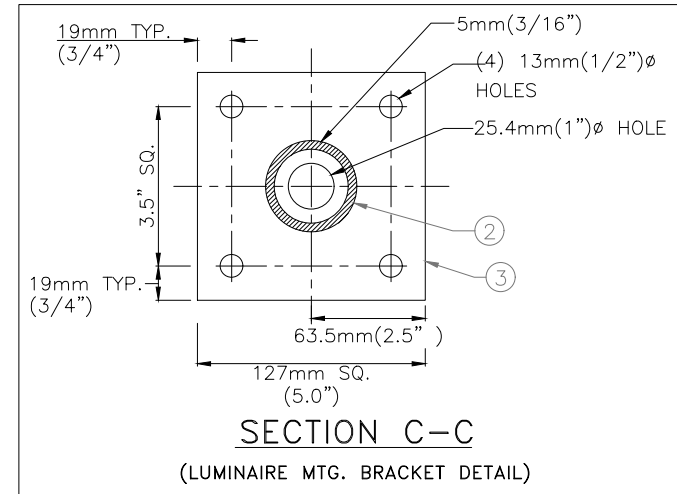

**mm** DIMENSIONS IN MILLIMETRES EXCEPT AS NOTED

4.		
3.		
2.		
1.		
REVISIONS		DATE



CITY OF VAUGHAN ENGINEERING STANDARD

## 1.8m (6') VICTORIAN SCROLL ARM

NOT TO SCALE      DESIGNED: \_\_\_\_\_  
REVISION: \_\_\_\_\_      DATE: \_\_\_\_\_ 2022

STD. DWG.  
**SL - 111**

Add File: C:\Users\adamg\OneDrive - City of Vaughan\Documents - PC\DWG\SL-112 - In Rev. Services - Map Rev\2022\SL-112 - 22 - Aluminum Bracket.dwg  
 Standard: Standard\STRUCTURE STANDARDS - NEW\SL-112 - 22 - Aluminum Bracket.dwg

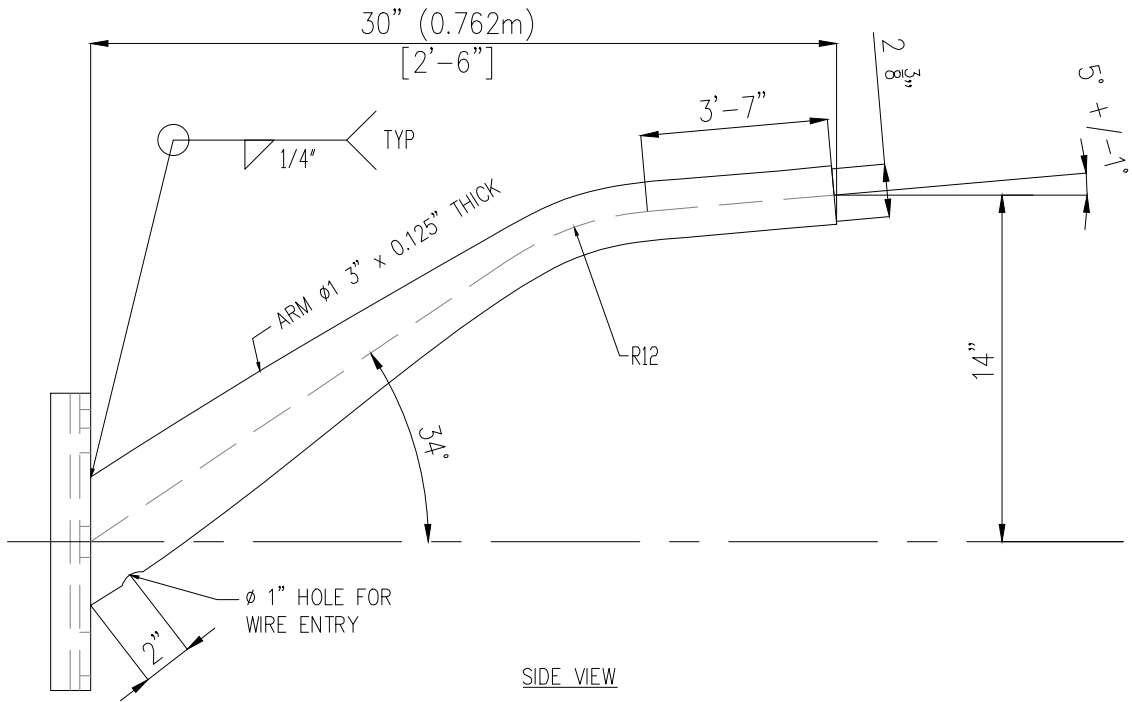

SIDE VIEW

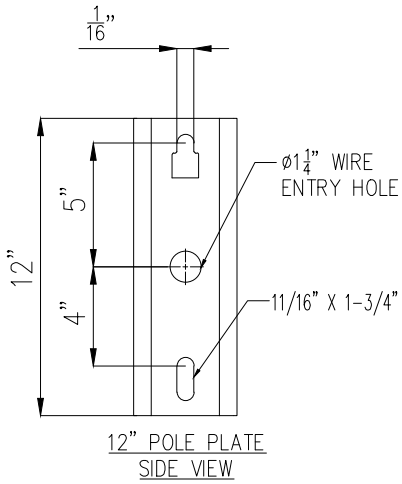

12" POLE PLATE  
SIDE VIEW

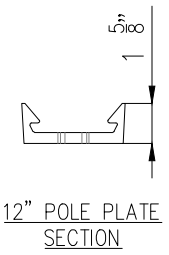

12" POLE PLATE  
SECTION

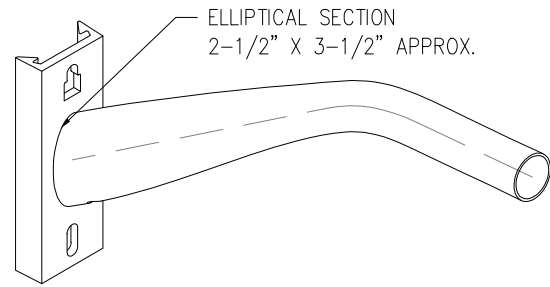

3D  
SIDE VIEW

BRACKET DESCRIPTION

BRACKET LENGTH: 2'-6" / 30"  
 FINISH: NATURAL BRUSH FINISH  
 MATERIAL: ALUMINUM  
 CONSTRUCTION: ARM TEMPERED: T6 - AFTER ALL OPERATIONS. ALL WELDING AS PER CSA 47.2

4.		
3.		
2.		
1.		
REVISIONS		DATE



CITY OF VAUGHAN ENGINEERING STANDARD

**30" (2.5') ALUMINUM  
ELLIPTICAL BRACKET**

NOT TO SCALE      DESIGNED: \_\_\_\_\_  
 REVISION: \_\_\_\_\_      DATE: 2022

STD. DWG.  
**SL-112**

Add File C:\Users\adamg\OneDrive - City of Vaughan\3 - PC FILES - In Rev. Services - Map Rev\2022\5 - Rev - Other\City M.S. - Standard\Standard\STRUCTURE STANDARDS - NEW\SL-113.dwg

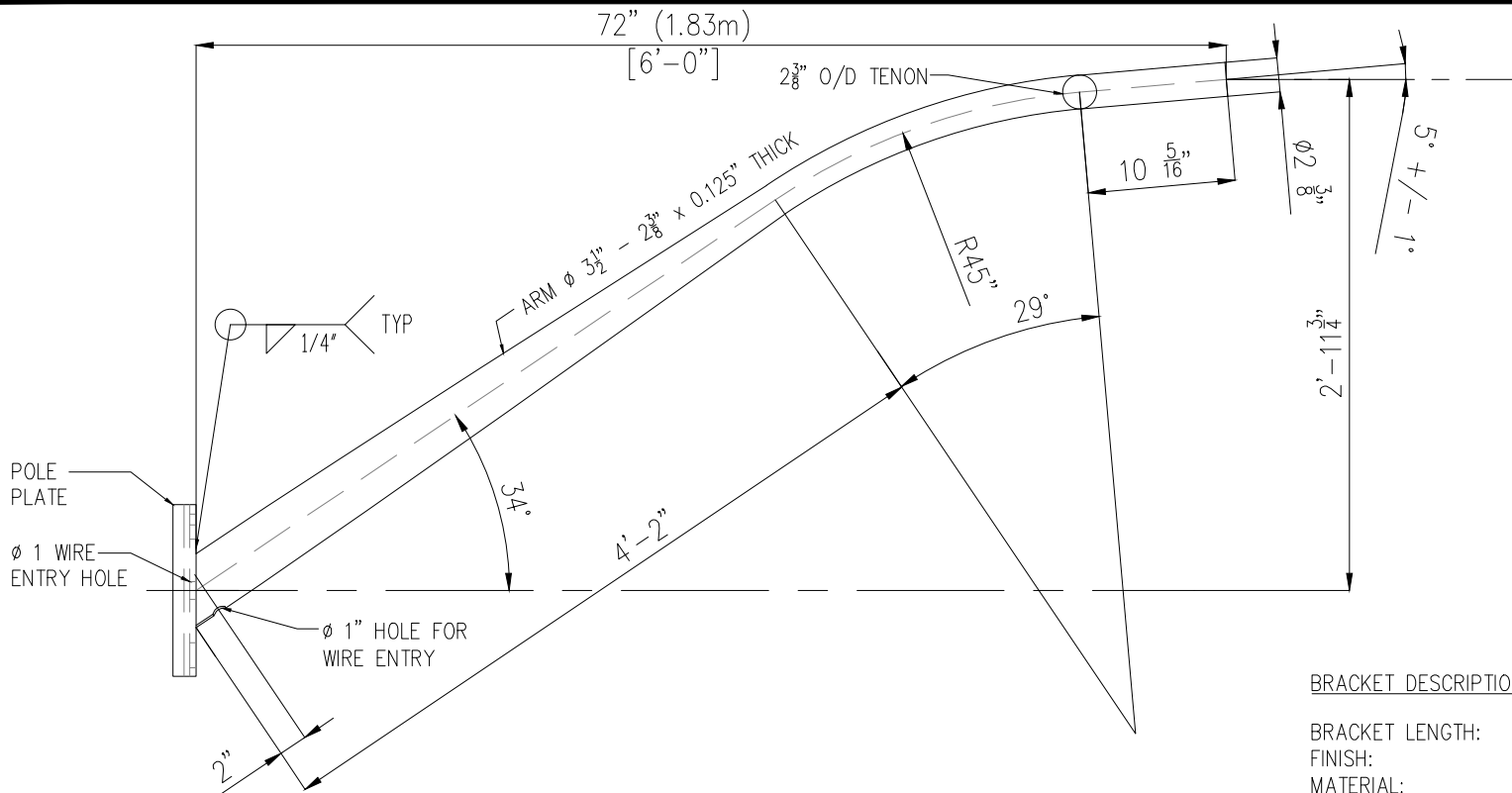

**BRACKET DESCRIPTION**

BRACKET LENGTH: 6'-0" / 72" / 1.83m  
 FINISH: NATURAL BRUSH FINISH  
 MATERIAL: ALUMINUM  
 CONSTRUCTION: ARM TEMPERED: T6 - AFTER ALL OPERATIONS. ALL WELDING AS PER CSA 47.2

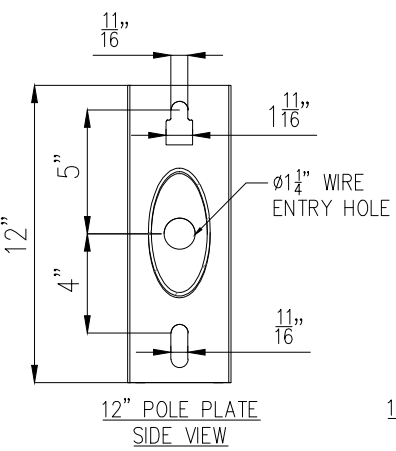

**12" POLE PLATE SECTION**

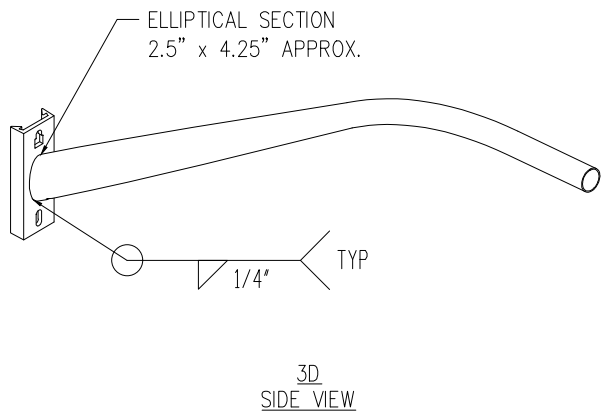

**3D SIDE VIEW**

4.		
3.		
2.		
1.		
REVISIONS		DATE



CITY OF VAUGHAN ENGINEERING STANDARD

**1.83m (6') ALUMINUM ELLIPTICAL BRACKET**

NOT TO SCALE      DESIGNED: \_\_\_\_\_  
 REVISION: \_\_\_\_\_      DATE: 2022

STD. DWG.  
**SL-113**

Add File C:\Users\adamg\OneDrive - City of Vaughan\3 - PC FILES - In Rev. Services - Map Rev\2022\3 - Rev - Other\City M.A.S. - Standard\Structure\STANDARD STANDARDS - REV\SL-114 - 8' Aluminum Bracket.dwg

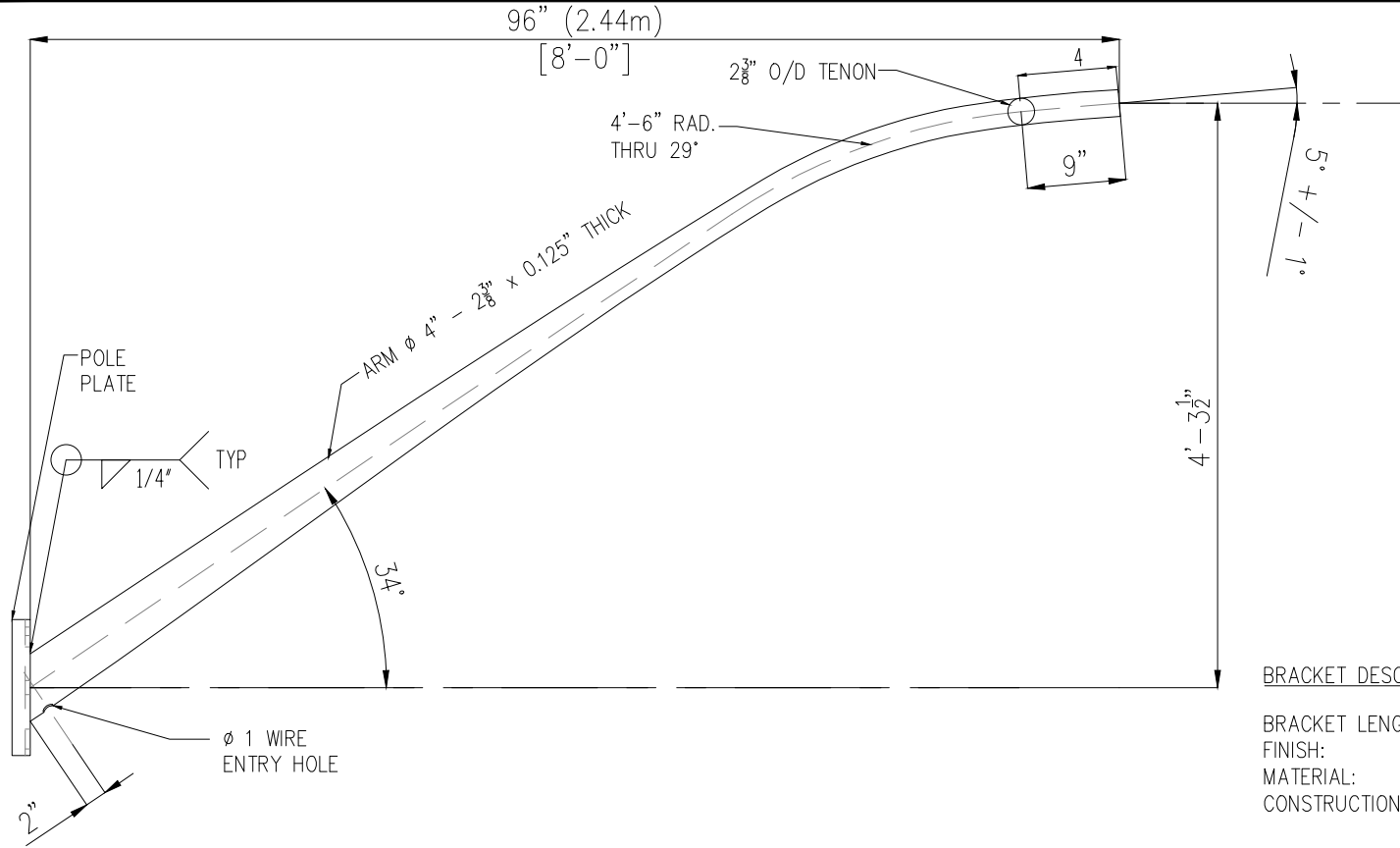

**BRACKET DESCRIPTION**

BRACKET LENGTH: 8'-0" / 96" / 2.44m  
 FINISH: NATURAL BRUSH FINISH  
 MATERIAL: ALUMINUM  
 CONSTRUCTION: ARM TEMPERED: T6 - AFTER ALL OPERATIONS. ALL WELDING AS PER CSA 47.2

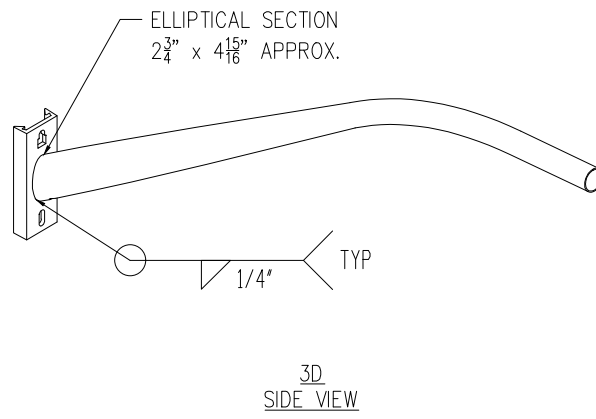
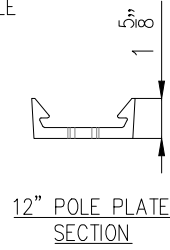
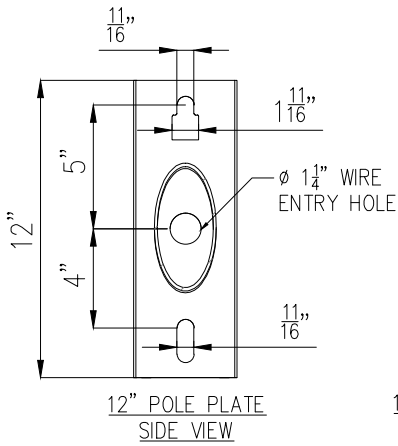

4.		
3.		
2.		
1.		
REVISIONS		DATE



CITY OF VAUGHAN ENGINEERING STANDARD

**2.44m (8') ALUMINUM ELLIPTICAL BRACKET**

NOT TO SCALE      DESIGNED: \_\_\_\_\_  
 REVISION: \_\_\_\_\_      DATE: \_\_\_\_\_ 2022

STD. DWG.  
**SL-114**

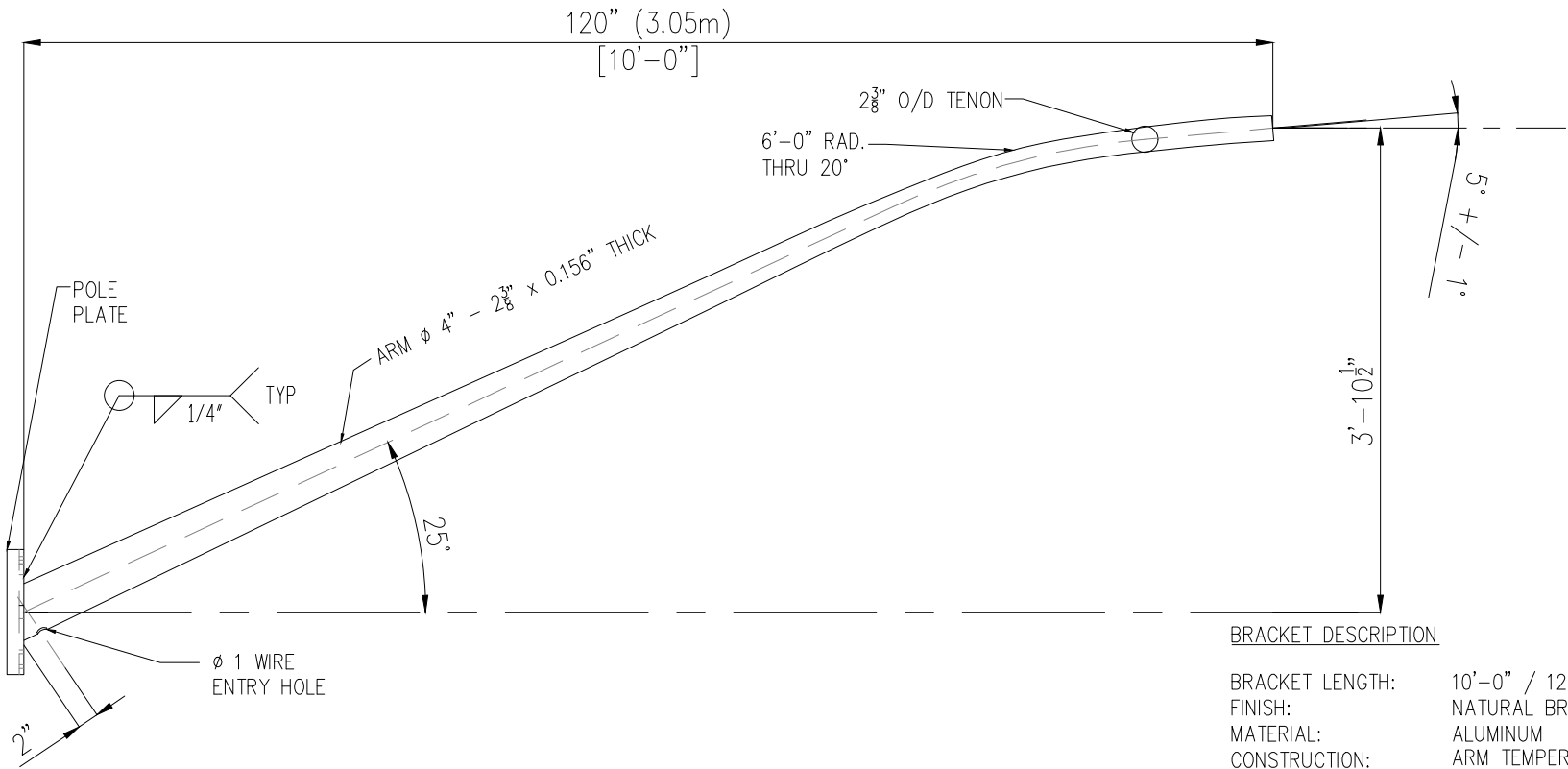

**BRACKET DESCRIPTION**

BRACKET LENGTH: 10'-0" / 120" / 3.05m  
 FINISH: NATURAL BRUSH FINISH  
 MATERIAL: ALUMINUM  
 CONSTRUCTION: ARM TEMPERED: T6 - AFTER ALL OPERATIONS. ALL WELDING AS PER CSA 47.2

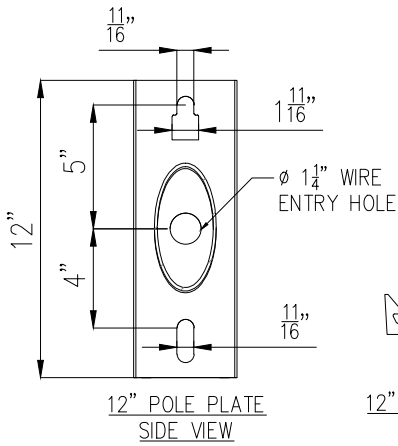

12" POLE PLATE SIDE VIEW

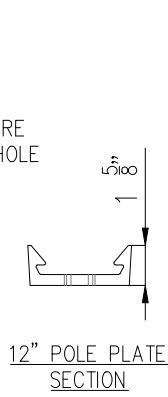

12" POLE PLATE SECTION

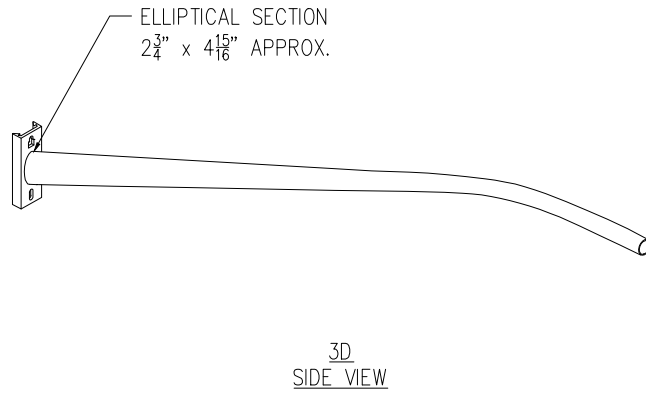

3D SIDE VIEW

4.		
3.		
2.		
1.		
REVISIONS		DATE



CITY OF VAUGHAN ENGINEERING STANDARD

**3m (10') ALUMINUM ELLIPTICAL BRACKET**

NOT TO SCALE      DESIGNED: \_\_\_\_\_  
 REVISION: \_\_\_\_\_      DATE: \_\_\_\_\_ 2022

STD. DWG.  
**SL-115**

And File: C:\Users\adam\OneDrive - City of Vaughan\City Standards - General Design Office\_2023\Std\SL-115 - 01 Aluminum Bracket.dwg



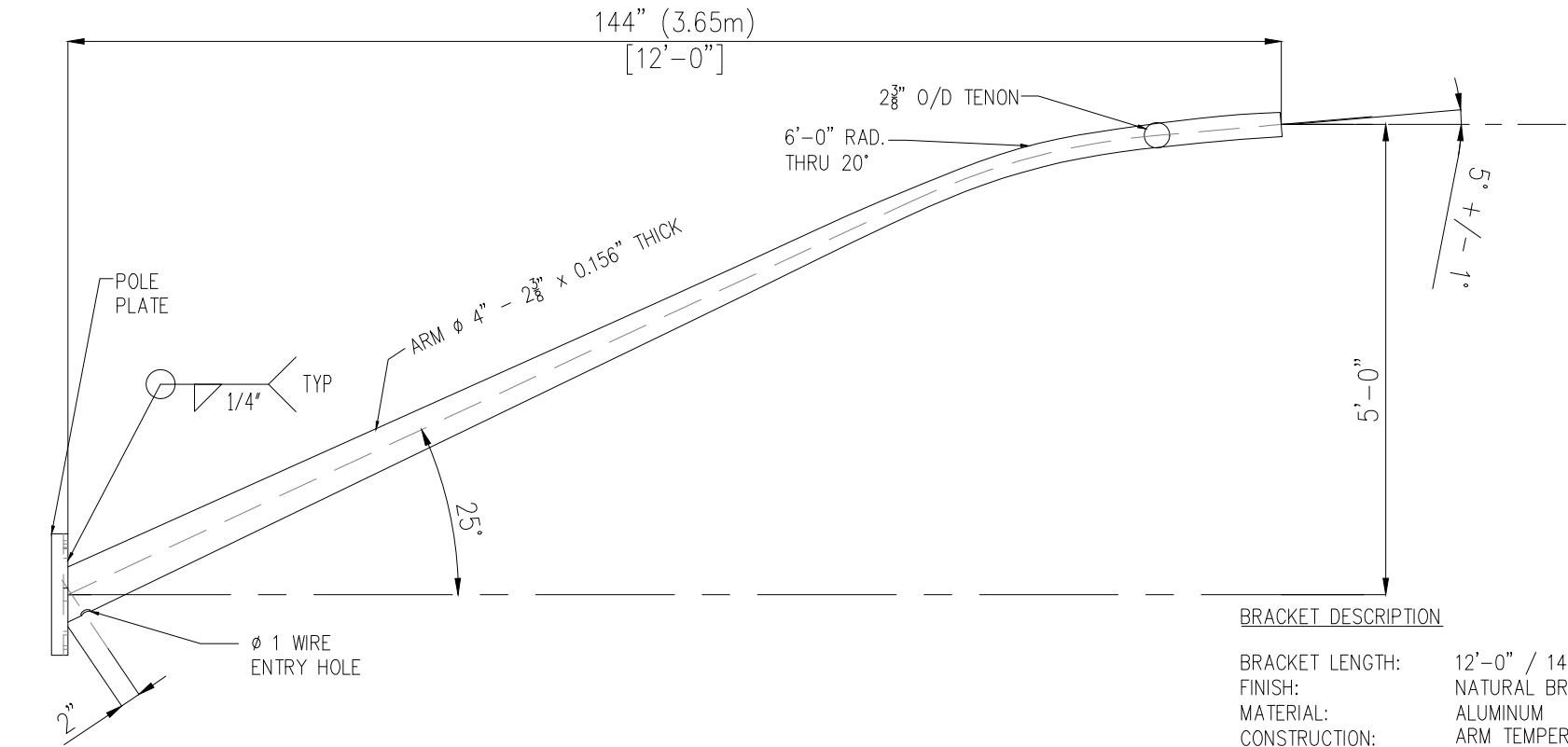

And File: C:\Users\adam\OneDrive - City of Vaughan\3 - PC FILES - In Rev. Service - Map Rev\2022\3 - Rev - Other\Site M.L. - Standard\Structural\STANDARDS - NEW\SL-116 - 12' Aluminum Bracket.dwg

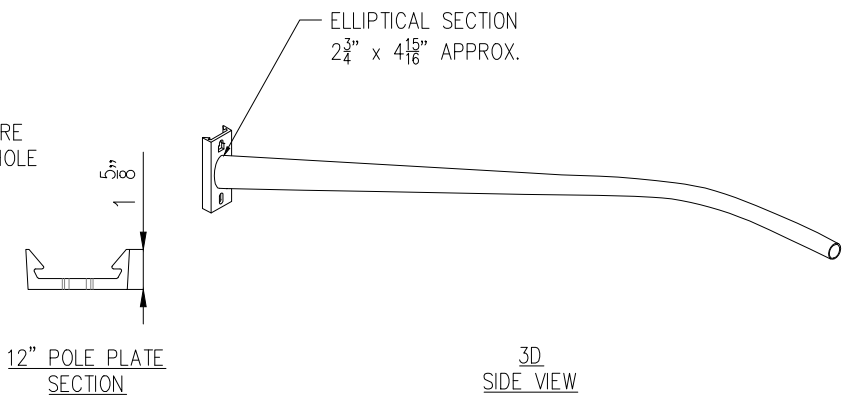
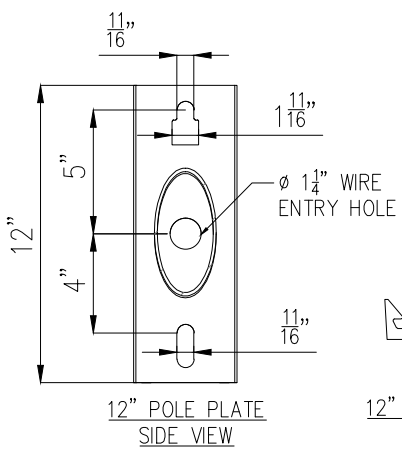

**BRACKET DESCRIPTION**

BRACKET LENGTH: 12'-0" / 144" / 3.65m  
 FINISH: NATURAL BRUSH FINISH  
 MATERIAL: ALUMINUM  
 CONSTRUCTION: ARM TEMPERED: T6 - AFTER ALL OPERATIONS. ALL WELDING AS PER CSA 47.2



4.		
3.		
2.		
1.		
REVISIONS		DATE
		
CITY OF VAUGHAN ENGINEERING STANDARD		
<b>3.65m (12') ALUMINUM          ELLIPTICAL BRACKET</b>		
NOT TO SCALE	DESIGNED: _____	STD. DWG.
REVISION: _____	DATE: _____ 2022	<b>SL-116</b>

Add File C:\Users\adamg\OneDrive - City of Vaughan\ - PC 2022\ - In Rev. Service - Map Rev\2022\ - Reg - Other\Site M.L.S. - Standard\Standard\STRUCTURE STANDARDS - NEW\SL-117 - 25' (7.6m) Tapered Round Concrete Pole.dwg

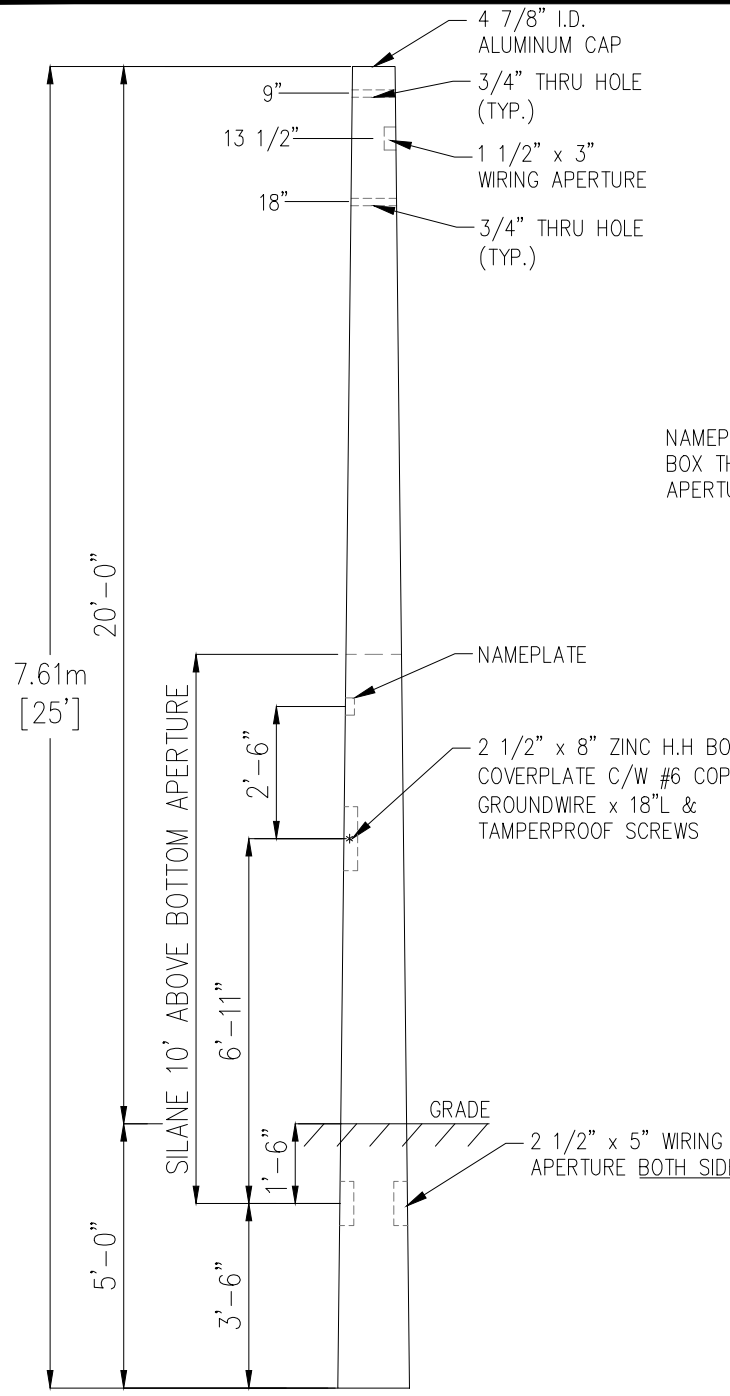

**POLE DESCRIPTION**

SECTION: ROUND  
 FINISH: MOULD FINISH  
 POLE TOP: 4 3/4" DIA.  
 POLE BUTT: 9 1/4" DIA.  
 POLE LENGTH: 25' 0"  
 APPROX. WGT.: 945 LBS.  
 MIN. RACEWAY: 1 1/8" ø

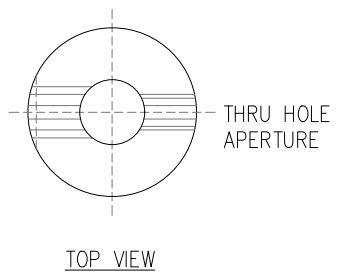

- NOTES:**
1. CABLE RACEWAY IN POLE MUST BE OF SUFFICIENT DIAMETER TO ACCOMMODATE A DOUBLE RUN OF U/G CABLE UP TO THE HANDHOLE.
  2. COPPER GROUND WIRE AT HANDHOLE IN ACCORDANCE WITH C.S.A. STANDARDS.
  3. HANDHOLE AND NAMEPLATE TO BE ON HOUSE SIDE OF POLE.

4.		
3.		
2.		
1.		
REVISIONS		DATE
CITY OF VAUGHAN ENGINEERING STANDARD		
<b>7.6m (25') TAPERED          ROUND CONCRETE POLE</b>		
NOT TO SCALE	DESIGNED: _____	STD. DWG.
REVISION: _____	DATE: 2022	<b>SL-117</b>

Add File C:\Users\adamg\OneDrive - City of Vaughan\ - PC 2018\ - In Rev. Service - Map Rev\2022\ - Reg - Other\Site M.L.S. - Standard\Standard\STRUCTURE STANDARDS - NEW\SL-118 - 3P (0.1m) Tapered Round Concrete FT Pole.dwg

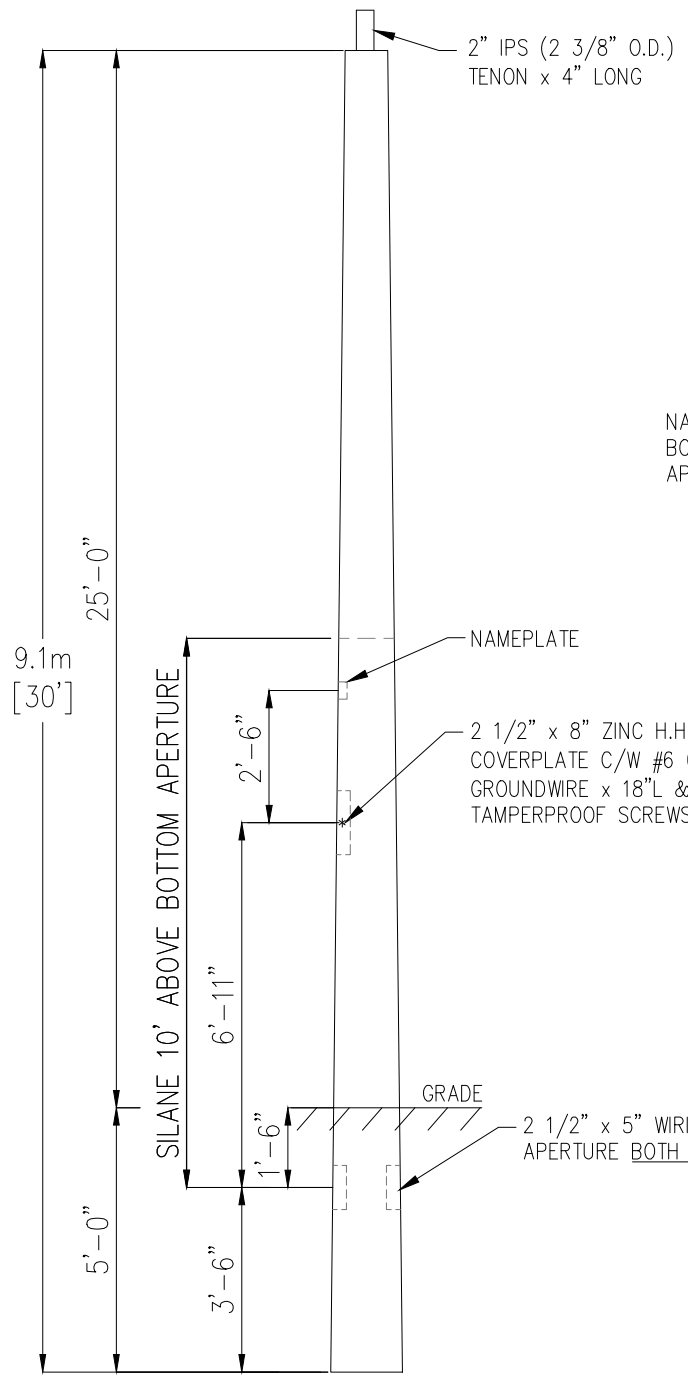

2" IPS (2 3/8" O.D.)  
TENON x 4" LONG

**POLE DESCRIPTION**

SECTION: ROUND  
 FINISH: MOULD FINISH  
 POLE TOP: 4 3/4" DIA.  
 POLE BUTT: 10 1/8" DIA.  
 POLE LENGTH: 30' 0"  
 APPROX. WGT.: 1,365 LBS.  
 MIN. RACEWAY: 1 1/8" ø

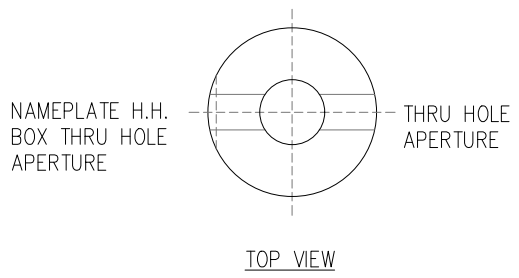

- NOTES:**
- CABLE RACEWAY IN POLE MUST BE OF SUFFICIENT DIAMETER TO ACCOMMODATE A DOUBLE RUN OF U/G CABLE UP TO THE HANDHOLE.
  - COPPER GROUND WIRE AT HANDHOLE IN ACCORDANCE WITH C.S.A. STANDARDS.
  - HANDHOLE AND NAMEPLATE TO BE ON HOUSE SIDE OF POLE.

NAMEPLATE

2 1/2" x 8" ZINC H.H. BOX & COVERPLATE C/W #6 COPPER GROUNDWIRE x 18"L & TAMPERPROOF SCREWS

GRADE

2 1/2" x 5" WIRING APERTURE BOTH SIDES

4.		
3.		
2.		
1.		
REVISIONS		DATE



CITY OF VAUGHAN ENGINEERING STANDARD

9.1m (30') TAPERED ROUND  
CONCRETE POST TOP POLE

NOT TO SCALE      DESIGNED: \_\_\_\_\_  
 REVISION: \_\_\_\_\_      DATE: 2022

STD. DWG.  
SL-118

Add File C:\Users\adamg\OneDrive - City of Vaughan\ - PC 24863 - In Rev. Services - Map Rev 02/2022 - Reg - Other (City, W.L. - Standard) Standard\STRUCTURE STANDARDS - NEW\SL-119 - 32.5' (9.9m) Tapered Round Concrete Pole.dwg

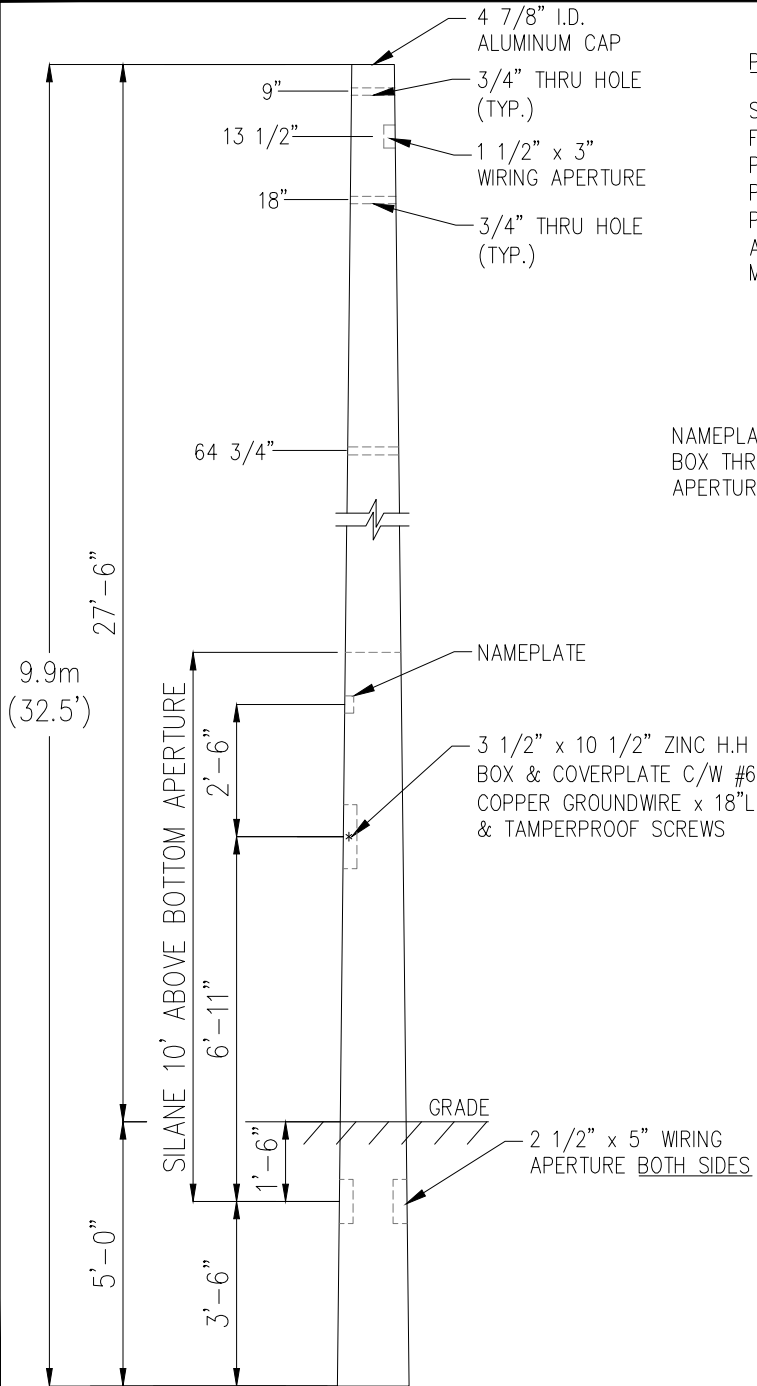

POLE DESCRIPTION

SECTION: ROUND  
 FINISH: MOULD FINISH  
 POLE TOP: 4 3/4" DIA.  
 POLE BUTT: 10 5/8" DIA.  
 POLE LENGTH: 32' 6"  
 APPROX. WGT.: 1,535 LBS.  
 MIN. RACEWAY: 1 1/8"  $\phi$

NOTES:

1. CABLE RACEWAY IN POLE MUST BE OF SUFFICIENT DIAMETER TO ACCOMMODATE A DOUBLE RUN OF U/G CABLE UP TO THE HANDHOLE.
2. COPPER GROUND WIRE AT HANDHOLE IN ACCORDANCE WITH C.S.A. STANDARDS.
3. HANDHOLE AND NAMEPLATE TO BE ON HOUSE SIDE OF POLE.

NAMEPLATE H.H. BOX THRU HOLE APERTURE

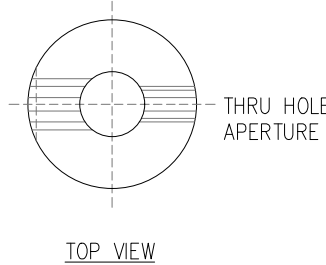

4.		
3.		
2.		
1.		
REVISIONS		DATE



CITY OF VAUGHAN ENGINEERING STANDARD

**9.9m (32.5') TAPERED  
 ROUND CONCRETE POLE**

NOT TO SCALE      DESIGNED: \_\_\_\_\_  
 REVISION: \_\_\_\_\_      DATE: 2022

STD. DWG.  
**SL-119**

Add File C:\Users\adamg\OneDrive - City of Vaughan\ - PC 24863 - In Rev. Services - Map Rev 02/2022 - Reg - Other (Site M.A.S. - Standardizing Standards) STRUCTURE STANDARDS - NEW SL-120 - 40' (12.2m) Tapered Round Concrete Pole.dwg

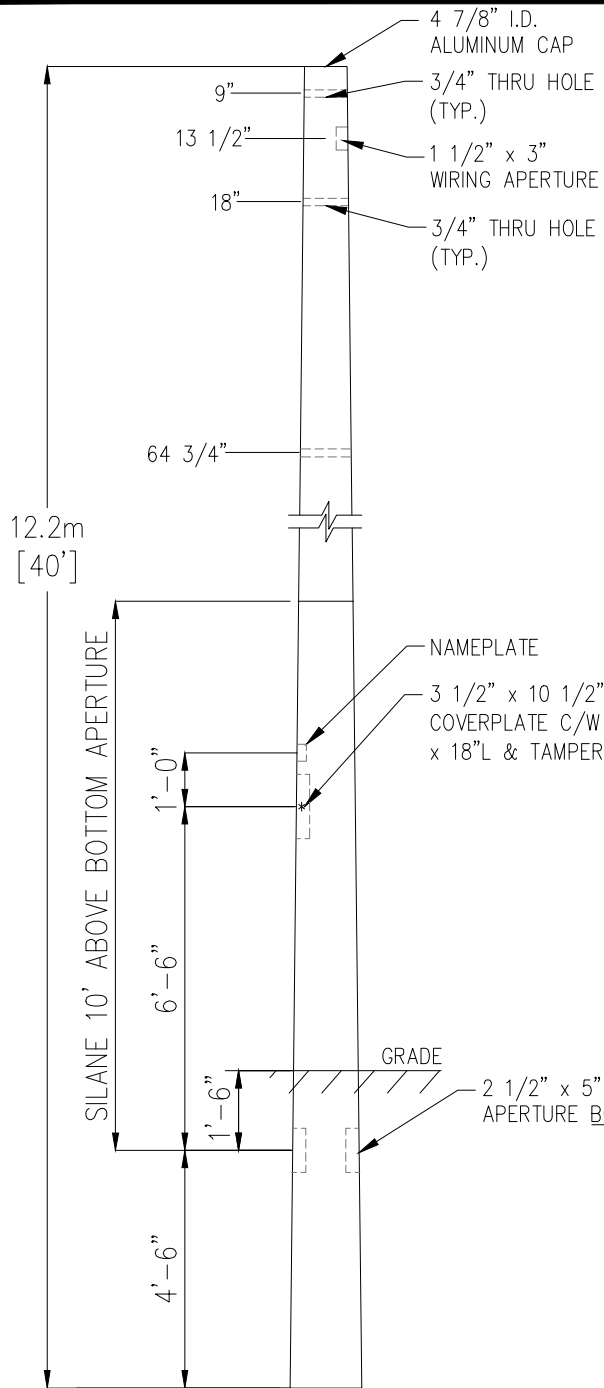

**POLE DESCRIPTION**

SECTION: ROUND  
 FINISH: MOULD FINISH  
 POLE TOP: 4 3/4" DIA.  
 POLE BUTT: 11 15/16" DIA.  
 POLE LENGTH: 40' 0"  
 APPROX. WGT.: 2,110 LBS.  
 MIN. RACEWAY: 1 1/8" ø

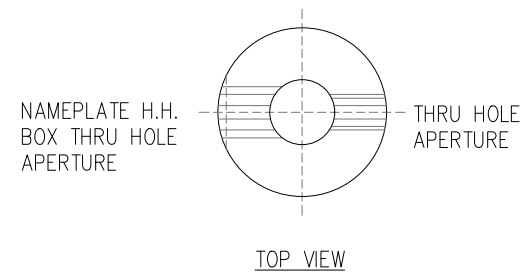

- NOTES:**
1. CABLE RACEWAY IN POLE MUST BE OF SUFFICIENT DIAMETER TO ACCOMMODATE A DOUBLE RUN OF U/G CABLE UP TO THE HANDHOLE.
  2. COPPER GROUND WIRE AT HANDHOLE IN ACCORDANCE WITH C.S.A. STANDARDS.
  3. HANDHOLE AND NAMEPLATE TO BE ON HOUSE SIDE OF POLE.

4.		
3.		
2.		
1.		
REVISIONS		DATE
CITY OF VAUGHAN ENGINEERING STANDARD		
<b>12.2m (40') TAPERED          ROUND CONCRETE POLE</b>		
NOT TO SCALE	DESIGNED: _____	STD. DWG.
REVISION: _____	DATE: _____ 2022	<b>SL-120</b>

Add File C:\Users\adamg\OneDrive - City of Vaughan\3 - PC FILES - In Rev. Services - Map Rev\2022\3 - Reg - Other\Site Plans - Standard\Standard\STRUCTURE STANDARDS - NEW\SL-121 - 42.5' (12.9m) Tapered Round Concrete Pole.dwg

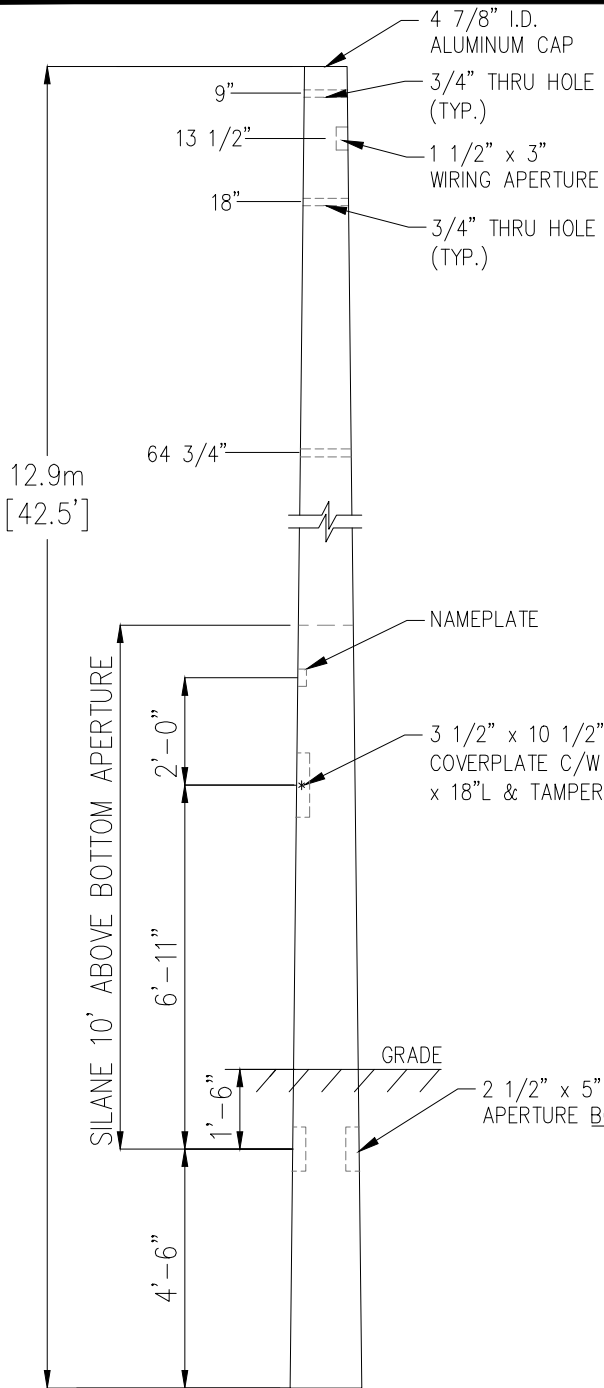

**POLE DESCRIPTION**

SECTION: ROUND  
 FINISH: MOULD FINISH  
 POLE TOP: 4 3/4" DIA.  
 POLE BUTT: 12 1/2" DIA.  
 POLE LENGTH: 42' 6"  
 APPROX. WGT.: 2,320 LBS.  
 MIN. RACEWAY: 1 1/8" Ø

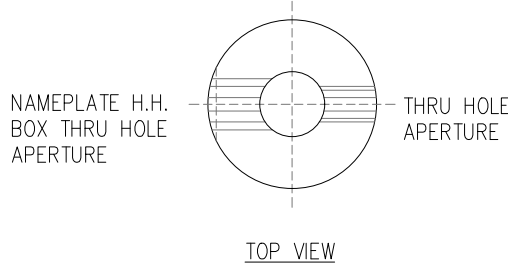

- NOTES:**
- CABLE RACEWAY IN POLE MUST BE OF SUFFICIENT DIAMETER TO ACCOMMODATE A DOUBLE RUN OF U/G CABLE UP TO THE HANDHOLE.
  - COPPER GROUND WIRE AT HANDHOLE IN ACCORDANCE WITH C.S.A. STANDARDS.
  - HANDHOLE AND NAMEPLATE TO BE ON HOUSE SIDE OF POLE.

4.		
3.		
2.		
1.		
REVISIONS		DATE
CITY OF VAUGHAN ENGINEERING STANDARD		
<b>12.9m (42.5') TAPERED          ROUND CONCRETE POLE</b>		
NOT TO SCALE	DESIGNED: _____	STD. DWG.
REVISION: _____	DATE: 2022	<b>SL-121</b>

Add File C:\Users\adamg\OneDrive - City of Vaughan\ - PC 248635 - In Rev. Services - Map Rev 202215 - Reg - Other (Site M.A.S. - Standard) Standard\STRUCTURE STANDARDS - NEW\SL-122 - 50' (15.2m) Tapered Round Concrete Pole.dwg

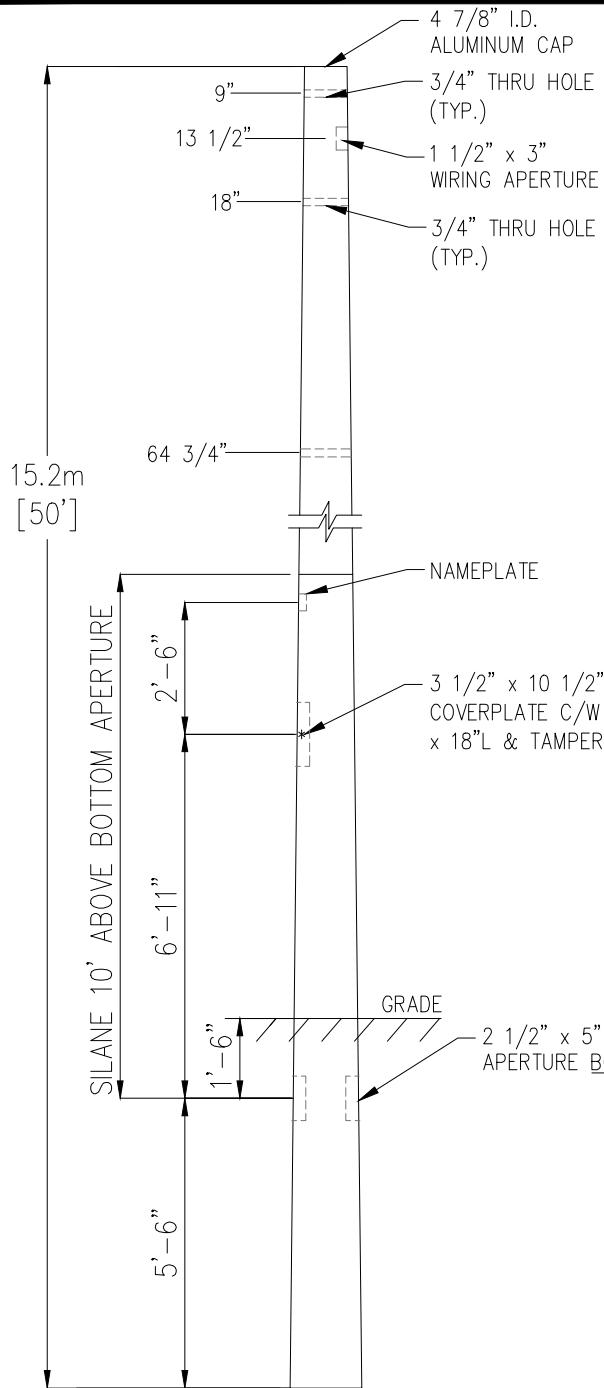

**POLE DESCRIPTION**

SECTION: ROUND  
 FINISH: MOULD FINISH  
 POLE TOP: 6 1/2" DIA.  
 POLE BUTT: 15 1/2" DIA.  
 POLE LENGTH: 50' 0"  
 APPROX. WGT.: 4,500 LBS.  
 MIN. RACEWAY: 1 1/8" Ø

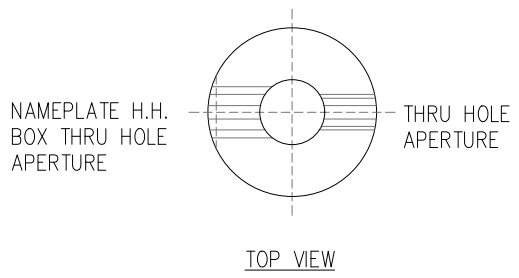

- NOTES:**
1. CABLE RACEWAY IN POLE MUST BE OF SUFFICIENT DIAMETER TO ACCOMMODATE A DOUBLE RUN OF U/G CABLE UP TO THE HANDHOLE.
  2. COPPER GROUND WIRE AT HANDHOLE IN ACCORDANCE WITH C.S.A. STANDARDS.
  3. HANDHOLE AND NAMEPLATE TO BE ON HOUSE SIDE OF POLE.

4.		
3.		
2.		
1.		
REVISIONS		DATE
<b>CITY OF VAUGHAN ENGINEERING STANDARD</b>		
<b>15.2m (50') TAPERED ROUND CONCRETE POLE</b>		
NOT TO SCALE	DESIGNED: _____	STD. DWG.
REVISION: _____	DATE: _____ 2022	<b>SL-122</b>

Add File C:\Users\adamg\OneDrive - City of Vaughan\3 - PC FILES - In Rev. Service - Map Rev\2022\3 - In Rev. Service - Standard\Standard\STRUCTURE STANDARDS - NEW\SL-123 - 17.5' (5.3m) Decorative Fluted Octagonal (Post Top) Pole.dwg

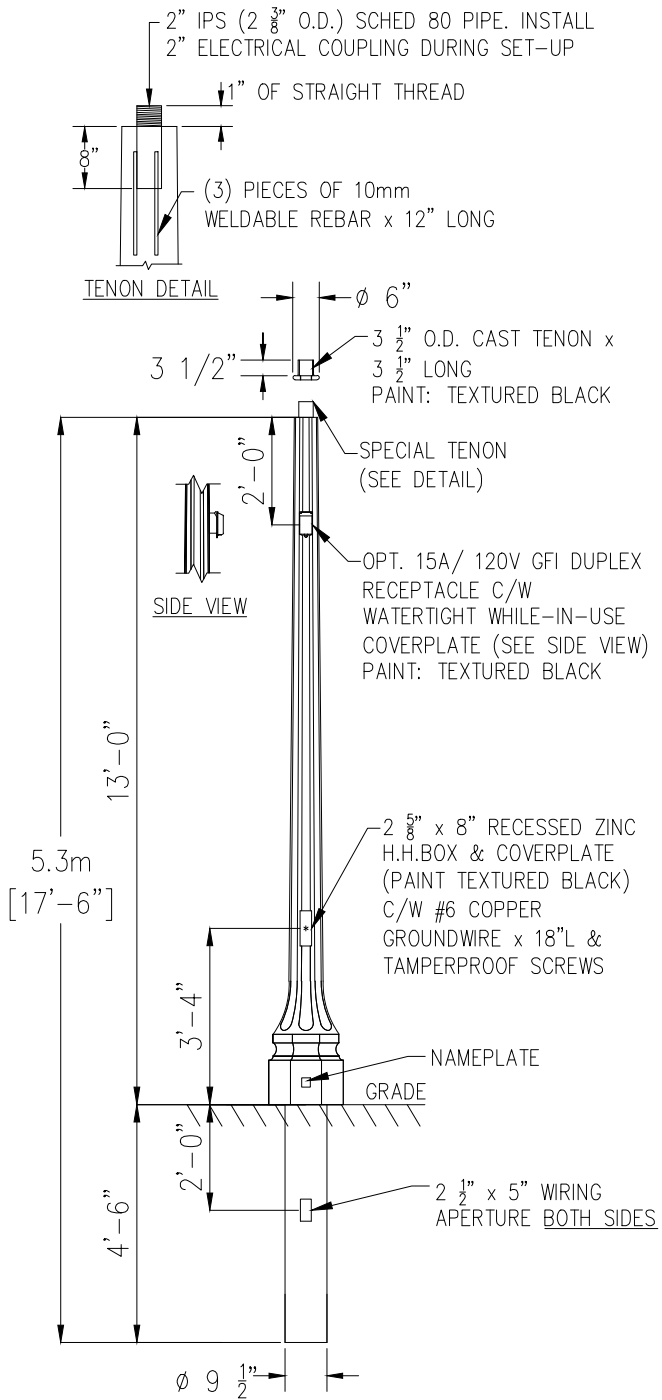

**POLE DESCRIPTION**

SECTION: FLUTED OCTAGONAL  
 FINISH: ECLIPSE ETCHED  
 POLE TOP: 5 1/2" DIA.  
 POLE BUTT: 9 1/2" DIA.  
 POLE LENGTH: 17' 6"  
 APPROX. WGT.: 1,075 LBS.  
 MIN. RACEWAY: 1 1/8" Ø  
 COATING REQ.: 2 COATS ACRYLIC (FULL LENGTH)

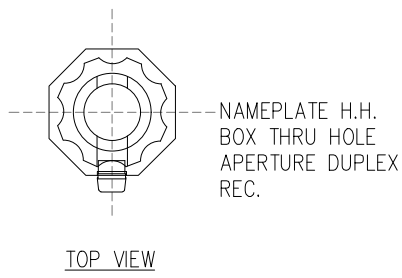

**NOTES:**

1. CABLE RACEWAY IN POLE MUST BE OF SUFFICIENT DIAMETER TO ACCOMMODATE A DOUBLE RUN OF U/G CABLE UP TO THE HANDHOLE.
2. COPPER GROUND WIRE AT HANDHOLE IN ACCORDANCE WITH C.S.A. STANDARDS.
3. HANDHOLE AND NAMEPLATE TO BE ON HOUSE SIDE OF POLE.

4.		
3.		
2.		
1.		
REVISIONS		DATE
		
CITY OF VAUGHAN ENGINEERING STANDARD		
<b>5.3m (17.5') DECORATIVE FLUTED OCTAGONAL (POST TOP) POLE</b>		
NOT TO SCALE	DESIGNED: _____	STD. DWG.
REVISION: _____	DATE: _____ 2022	<b>SL-123</b>



POLE DESCRIPTION

SECTION: OCTAGONAL  
 FINISH: ECLIPSE POLISHED  
 POLE TOP: 4" FL/FL  
 POLE BUTT: 8 1/4" DIA.  
 POLE LENGTH: 19' 7"  
 APPROX. WGT.: 740 LBS.  
 MIN. RACEWAY: 1 1/8" Ø  
 COATING REQ.: 2 COATS ACRYLIC (FULL LENGTH)

NOTES:

1. CABLE RACEWAY IN POLE MUST BE OF SUFFICIENT DIAMETER TO ACCOMMODATE A DOUBLE RUN OF U/G CABLE UP TO THE HANDHOLE.
2. COPPER GROUND WIRE AT HANDHOLE IN ACCORDANCE WITH C.S.A. STANDARDS.
3. HANDHOLE AND NAMEPLATE TO BE ON HOUSE SIDE OF POLE.

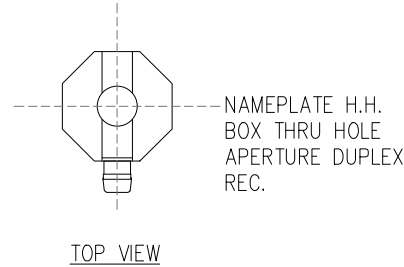
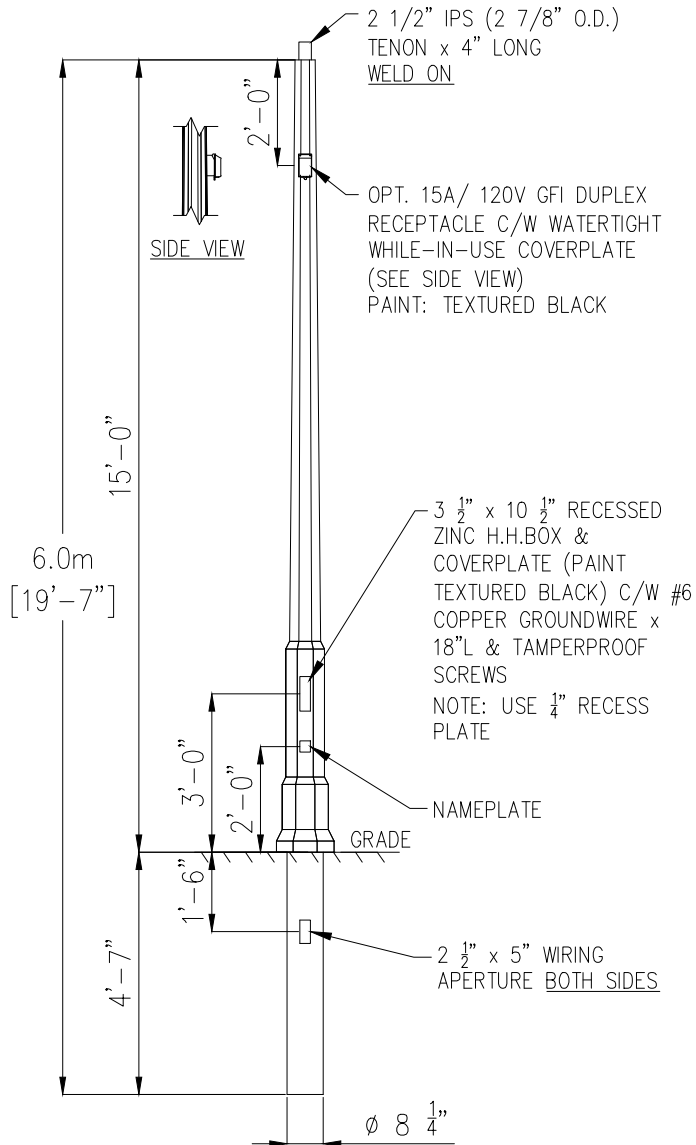

Add File C:\Users\adamg\OneDrive - City of Vaughan\3 - PC FILES\3 - In Rev. Services - Map Rev\2022\3 - Reg - Other\City M.S. - Standards\Structure\STANDARDS - NEW\SL-124 - 19' (6m) Decorative Pole Components (Post Top) Rev.dwg

4.		
3.		
2.		
1.		
REVISIONS		DATE



CITY OF VAUGHAN ENGINEERING STANDARD

6m (19.6') DECORATIVE  
 OCTAGONAL (POST TOP)  
 POLE

NOT TO SCALE      DESIGNED: \_\_\_\_\_  
 REVISION: \_\_\_\_\_      DATE: \_\_\_\_\_ 2022

STD. DWG.  
 SL-124

Add File C:\Users\adamg\OneDrive - City of Vaughan\ - PC 20180518 - In Rev. Service - Map Rev 000003 - Reg - Other\City M.A.S. - Standards\Standard\STRUCTURE STANDARDS - NEW\SL-125 - 20' (6.1m) Tapered Octagonal (Post Top) Pole.dwg

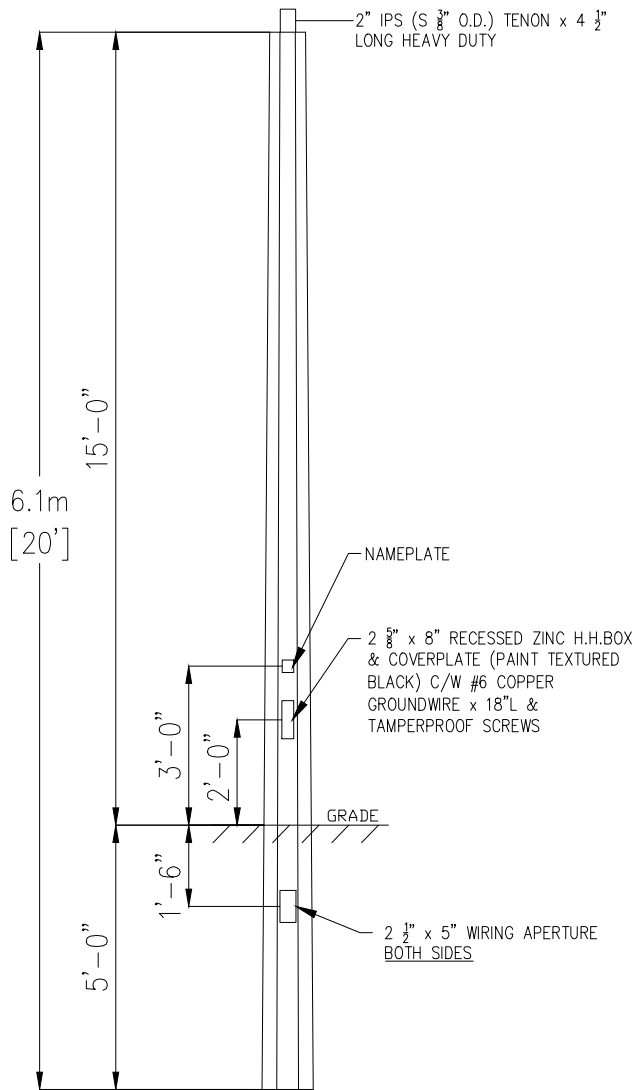

POLE DESCRIPTION

SECTION: OCTAGONAL  
 FINISH: ECLIPSE ETCHED  
 POLE TOP: 5 3/8" FL/FL  
 POLE BUTT: 7 7/8" FL/FL  
 POLE LENGTH: 20' 0"  
 APPROX. WGT.: 770 LBS.  
 MIN. RACEWAY: 1 1/8"  $\phi$   
 COATING REQ.: 2 COATS ACRYLIC (FULL LENGTH)

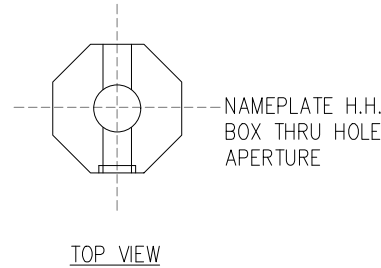

NOTES:

1. CABLE RACEWAY IN POLE MUST BE OF SUFFICIENT DIAMETER TO ACCOMMODATE A DOUBLE RUN OF U/G CABLE UP TO THE HANDHOLE.
2. COPPER GROUND WIRE AT HANDHOLE IN ACCORDANCE WITH C.S.A. STANDARDS.
3. HANDHOLE AND NAMEPLATE TO BE ON HOUSE SIDE OF POLE.

4.		
3.		
2.		
1.		
REVISIONS		DATE
		
CITY OF VAUGHAN ENGINEERING STANDARD		
<b>6.1m (20') TAPERED OCTAGONAL (POST TOP) POLE</b>		
NOT TO SCALE	DESIGNED: _____	STD. DWG.
REVISION: _____	DATE: _____ 2022	<b>SL-125</b>

Add File C:\Users\adamg\OneDrive - City of Vaughan\3 - PC FILES - In Rev. Services - Map Rev\2022\3 - Reg - Other\Site Plans - Standard\Standard\STRUCTURE STANDARDS - NEW\SL-126 - 20' (6.1m) Tapered Octagonal Pole.dwg

POLE DESCRIPTION

SECTION: OCTAGONAL  
 FINISH: SALUKI BRONZE POLISHED  
 POLE TOP: 5 3/8" FL/FL  
 POLE BUTT: 7 7/8" FL/FL  
 POLE LENGTH: 20' 0"  
 APPROX. WGT.: 712 LBS.  
 MIN. RACEWAY: 1 1/8" Ø  
 COATING REQ.: 2 COATS ACRYLIC (FULL LENGTH)

NOTES:

1. CABLE RACEWAY IN POLE MUST BE OF SUFFICIENT DIAMETER TO ACCOMMODATE A DOUBLE RUN OF U/G CABLE UP TO THE HANDHOLE.
2. COPPER GROUND WIRE AT HANDHOLE IN ACCORDANCE WITH C.S.A. STANDARDS.
3. HANDHOLE AND NAMEPLATE TO BE ON HOUSE SIDE OF POLE.

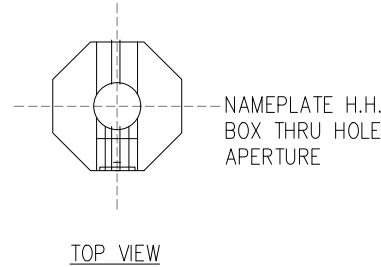
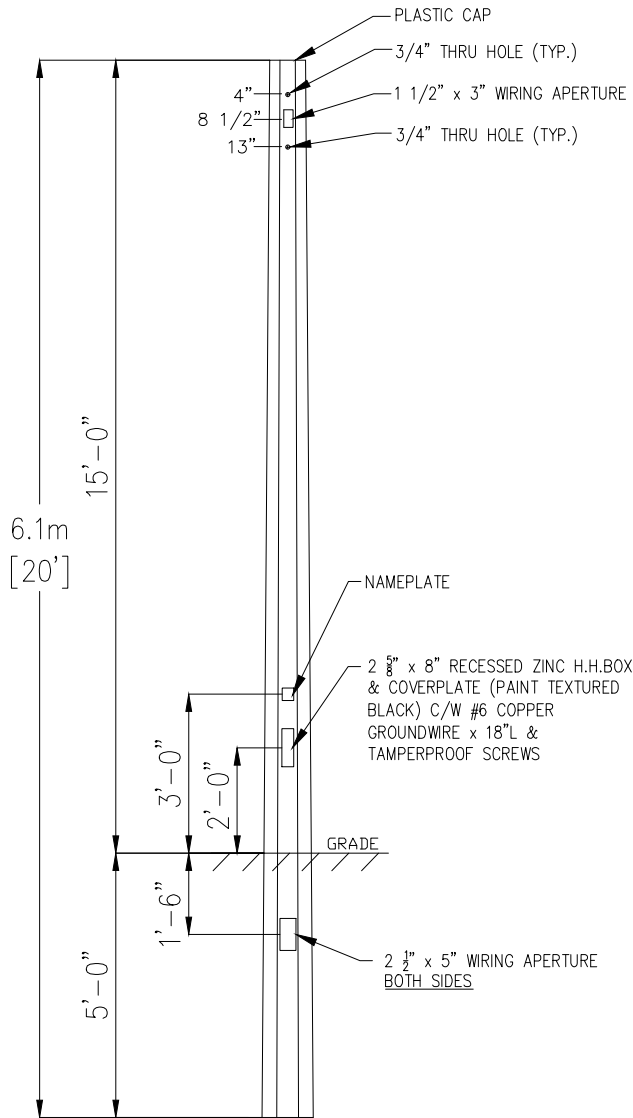

4.		
3.		
2.		
1.		
REVISIONS		DATE
		
CITY OF VAUGHAN ENGINEERING STANDARD		
<b>6.1m (20') TAPERED OCTAGONAL POLE</b>		
NOT TO SCALE	DESIGNED: _____	STD. DWG.
REVISION: _____	DATE: _____ 2022	<b>SL-126</b>

Add File: C:\Infrastructure\Delivery\Infrastructure - Programming\DWG\CITY STANDARD\Design - Other\2020\CITY STANDARD\Utility - Other\VAUGHAN\SL-127 - 32.5' (8m) Tapered Octagonal Pole.dwg

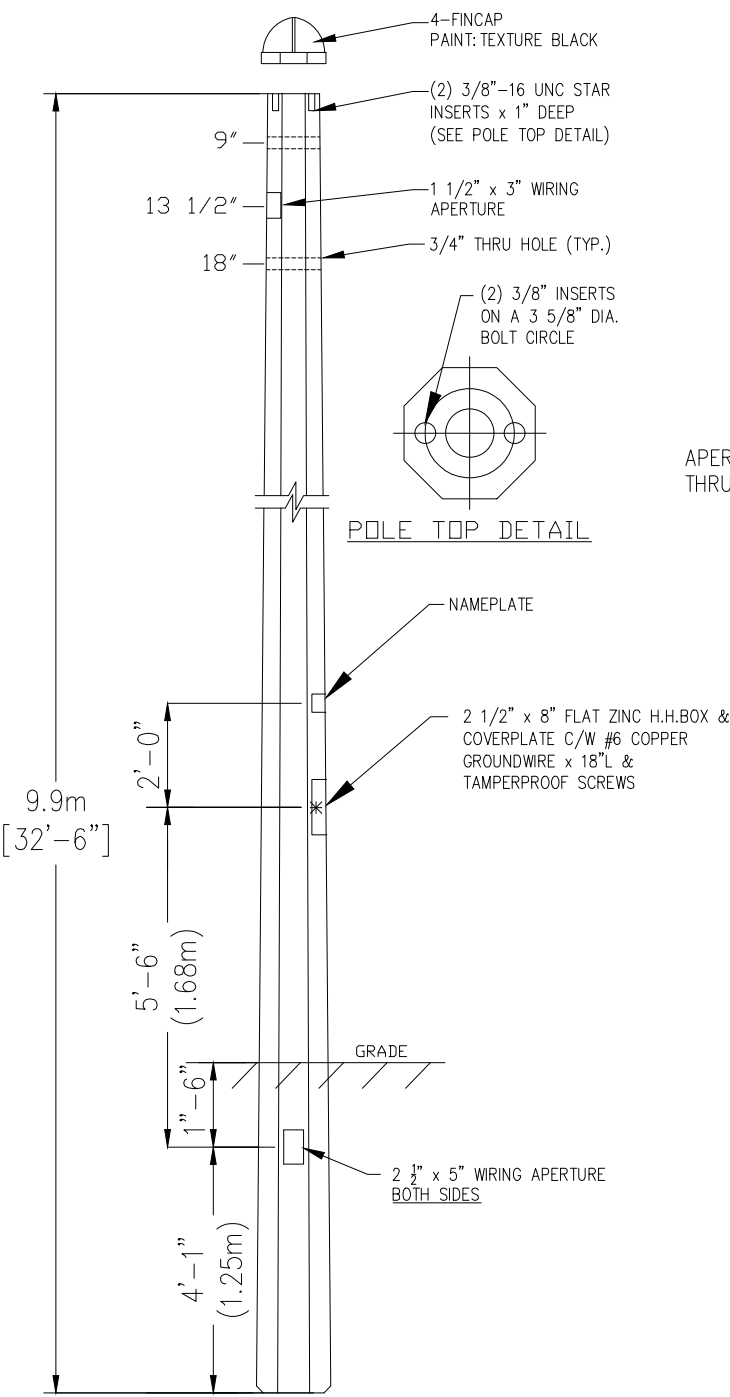

**POLE DESCRIPTION**

SECTION: OCTAGONAL  
 FINISH: ECLIPSE (BLACK) POLISHED  
 POLE TOP: 5 3/8" FL/FL  
 POLE BUTT: 9 7/16" FL/FL  
 POLE LENGTH: 32' 6"  
 APPROX. WGT.: 1,500 LBS.  
 MIN. RACEWAY: 1 1/8" Ø  
 COATING REQ.: 2 COATS ACRYLIC  
 (FULL LENGTH)

**NOTES:**

1. CABLE RACEWAY IN POLE MUST BE OF SUFFICIENT DIAMETER TO ACCOMMODATE A DOUBLE RUN OF U/G CABLE UP TO THE HANDHOLE.
2. COPPER GROUND WIRE AT HANDHOLE IN ACCORDANCE WITH C.S.A. STANDARDS.
3. HANDHOLE AND NAMEPLATE TO BE ON HOUSE SIDE OF POLE.

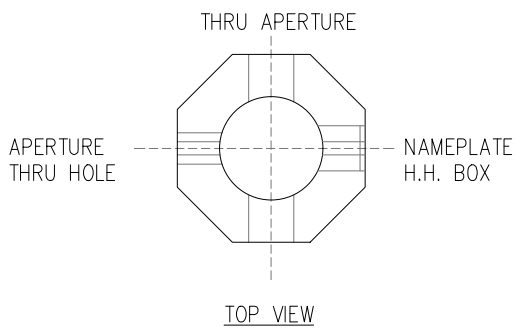
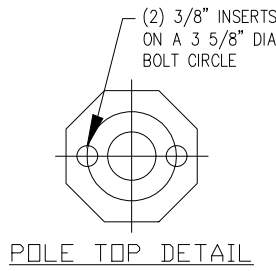

4.		
3.		
2.		
1.		
REVISIONS		DATE



CITY OF VAUGHAN ENGINEERING STANDARD

9.9m (32.5') TAPERED  
OCTAGONAL POLE

NOT TO SCALE      DESIGNED: \_\_\_\_\_  
 REVISION: \_\_\_\_\_      DATE: 2022

STD. DWG.  
**SL-127**



Add. Pict. © Infrastructure Delivery/Infrastructure Programming/PAO/City Standards/Design Office, 2020/City Standards Update Model/Construction/PAO, 2020/US Standards/US-129 - 27' (8.2m) Decorative Octagonal Pole/4m

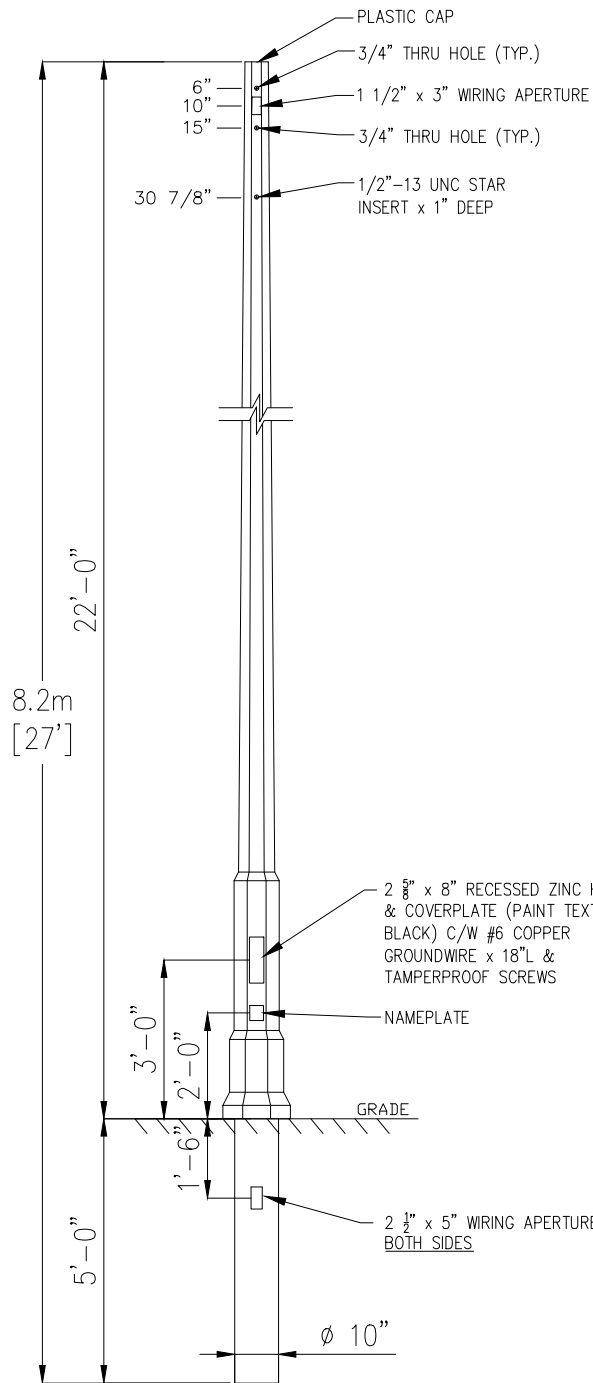

**POLE DESCRIPTION**

SECTION: OCTAGONAL  
 FINISH: ECLIPSE POLISHED  
 POLE TOP: 5 7/16" FL/FL  
 POLE BUTT: 10" FL/FL  
 POLE LENGTH: 27' 0"  
 APPROX. WGT.: 1,445 LBS.  
 MIN. RACEWAY: 1 1/8" Ø  
 COATING REQ.: 2 COATS ACRYLIC (FULL LENGTH)

**NOTES:**

1. CABLE RACEWAY IN POLE MUST BE OF SUFFICIENT DIAMETER TO ACCOMMODATE A DOUBLE RUN OF U/G CABLE UP TO THE HANDHOLE.
2. COPPER GROUND WIRE AT HANDHOLE IN ACCORDANCE WITH C.S.A. STANDARDS.
3. HANDHOLE AND NAMEPLATE TO BE ON HOUSE SIDE OF POLE.

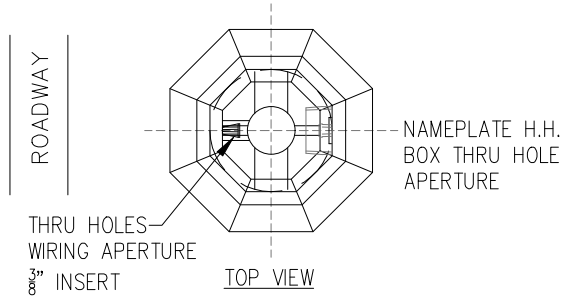

4.		
3.		
2.		
1.		
REVISIONS		DATE



CITY OF VAUGHAN ENGINEERING STANDARD

**8.2m (27') DECORATIVE OCTAGONAL POLE**

NOT TO SCALE      DESIGNED: \_\_\_\_\_  
 REVISION: \_\_\_\_\_      DATE: 2022

STD. DWG.  
**SL-129**

Add. File: C:\Infrastructure\Delivery\Infrastructure - Programming\DWG\CITY STANDARDS\Design - Other - 2020\CITY STANDARDS - Utilities - Pole\Color\stdengr.dwg, 2020, US - 32' (9.75m) Decorative Fluted Octagonal Pole.dwg

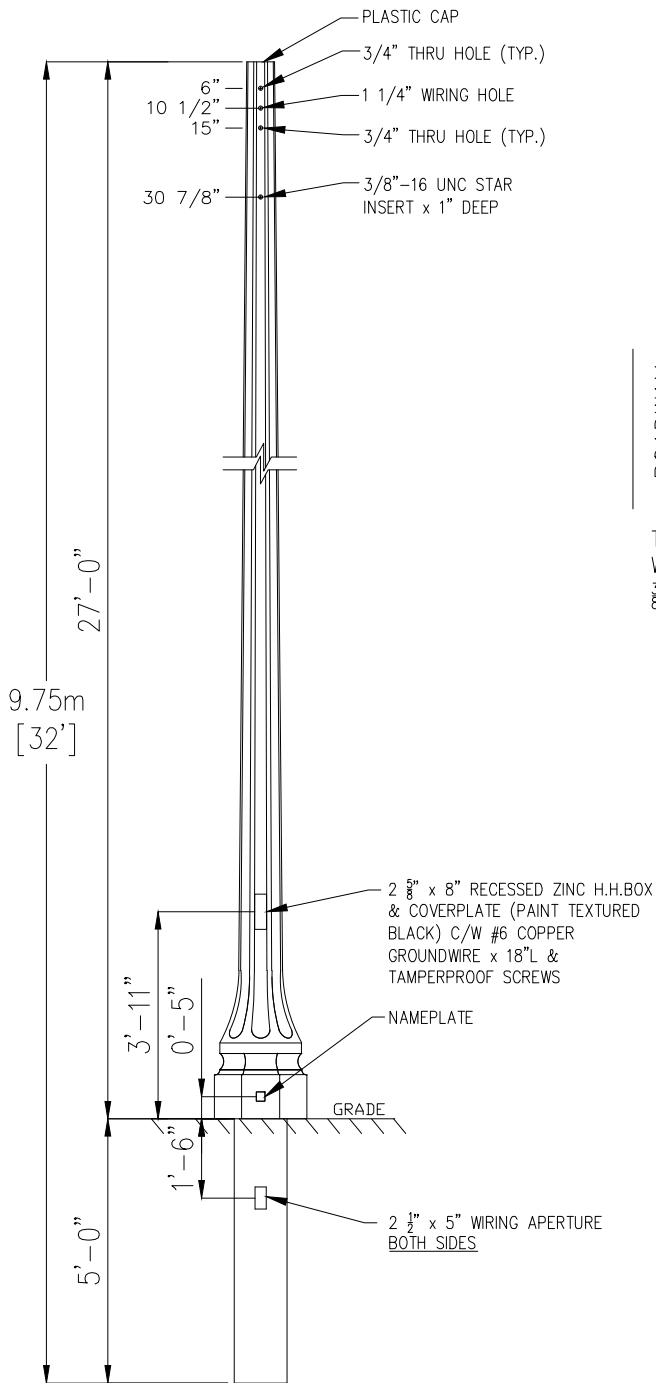

**POLE DESCRIPTION**

SECTION:	OCTAGONAL
FINISH:	ECLIPSE POLISHED
POLE TOP:	5 7/16" FL/FL
POLE BUTT:	10" FL/FL
POLE LENGTH:	27' 0"
APPROX. WGT.:	1,445 LBS.
MIN. RACEWAY:	1 1/8" Ø
COATING REQ.:	2 COATS ACRYLIC (FULL LENGTH)

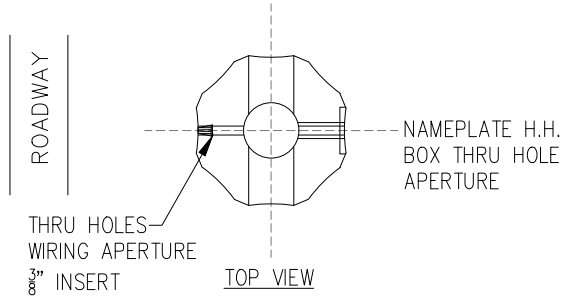

- NOTES:**
1. CABLE RACEWAY IN POLE MUST BE OF SUFFICIENT DIAMETER TO ACCOMMODATE A DOUBLE RUN OF U/G CABLE UP TO THE HANDHOLE.
  2. COPPER GROUND WIRE AT HANDHOLE IN ACCORDANCE WITH C.S.A. STANDARDS.
  3. HANDHOLE AND NAMEPLATE TO BE ON HOUSE SIDE OF POLE.

4.		
3.		
2.		
1.		
REVISIONS		DATE



**CITY OF VAUGHAN ENGINEERING STANDARD**

**9.75m (32') DECORATIVE FLUTED OCTAGONAL POLE**

NOT TO SCALE	DESIGNED: _____	STD. DWG. <b>SL-130</b>
REVISION: _____	DATE: 2022 _____	





Add File: C:\Infrastructure\Delivery\Infrastructure - Programming\DWG\CITY STANDARDS\Design - Other - 2020\CITY STANDARDS - Utilities - Pole\Color\stdengr.dwg, 2020, US, Standard\US - 12 - 36.5' (11.1m) Decorative - Octagonal Pole.dwg

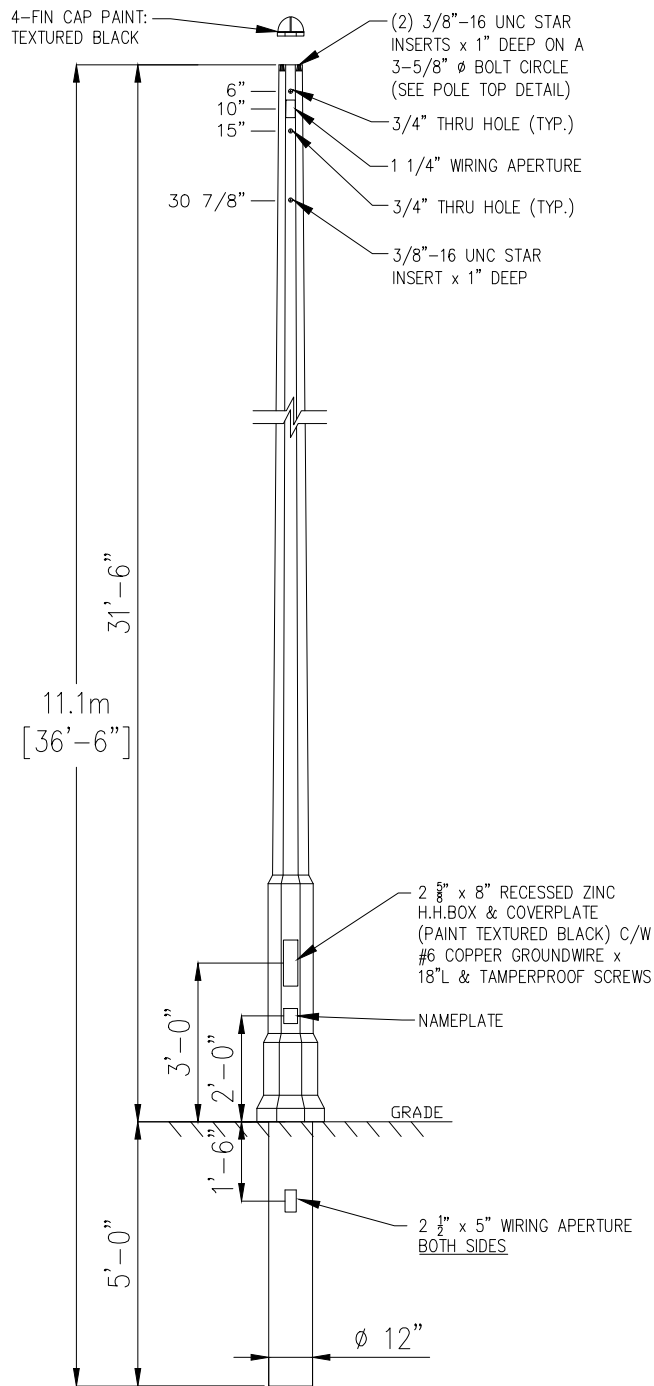

**POLE DESCRIPTION**

SECTION: OCTAGONAL  
 FINISH: ECLIPSE ETCHED  
 POLE TOP: 6 1/4" FL/FL  
 POLE BUTT: 22" DIA.  
 POLE LENGTH: 32' 6"  
 APPROX. WGT.: 4,365 LBS.  
 MIN. RACEWAY: 1 1/8" Ø  
 COATING REQ.: 2 COATS ACRYLIC (FULL LENGTH)

**NOTES:**

1. CABLE RACEWAY IN POLE MUST BE OF SUFFICIENT DIAMETER TO ACCOMMODATE A DOUBLE RUN OF U/G CABLE UP TO THE HANDHOLE.
2. COPPER GROUND WIRE AT HANDHOLE IN ACCORDANCE WITH C.S.A. STANDARDS.
3. HANDHOLE AND NAMEPLATE TO BE ON HOUSE SIDE OF POLE.

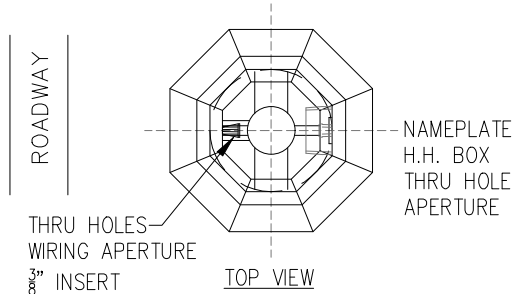

4.		
3.		
2.		
1.		
REVISIONS		DATE



CITY OF VAUGHAN ENGINEERING STANDARD

11.1m (36.5') DECORATIVE OCTAGONAL POLE

NOT TO SCALE  
 DESIGNED: \_\_\_\_\_  
 REVISION: \_\_\_\_\_  
 DATE: 2022

STD. DWG.  
 SL-132

Add File: C:\Users\vaughan\CITY OF VAUGHAN\City Standards - General\Design\Other\2023\Std. Drawing\SL-133 - 6.1m (20') - Pole Assembly Walkway-Pathway Lighting.dwg

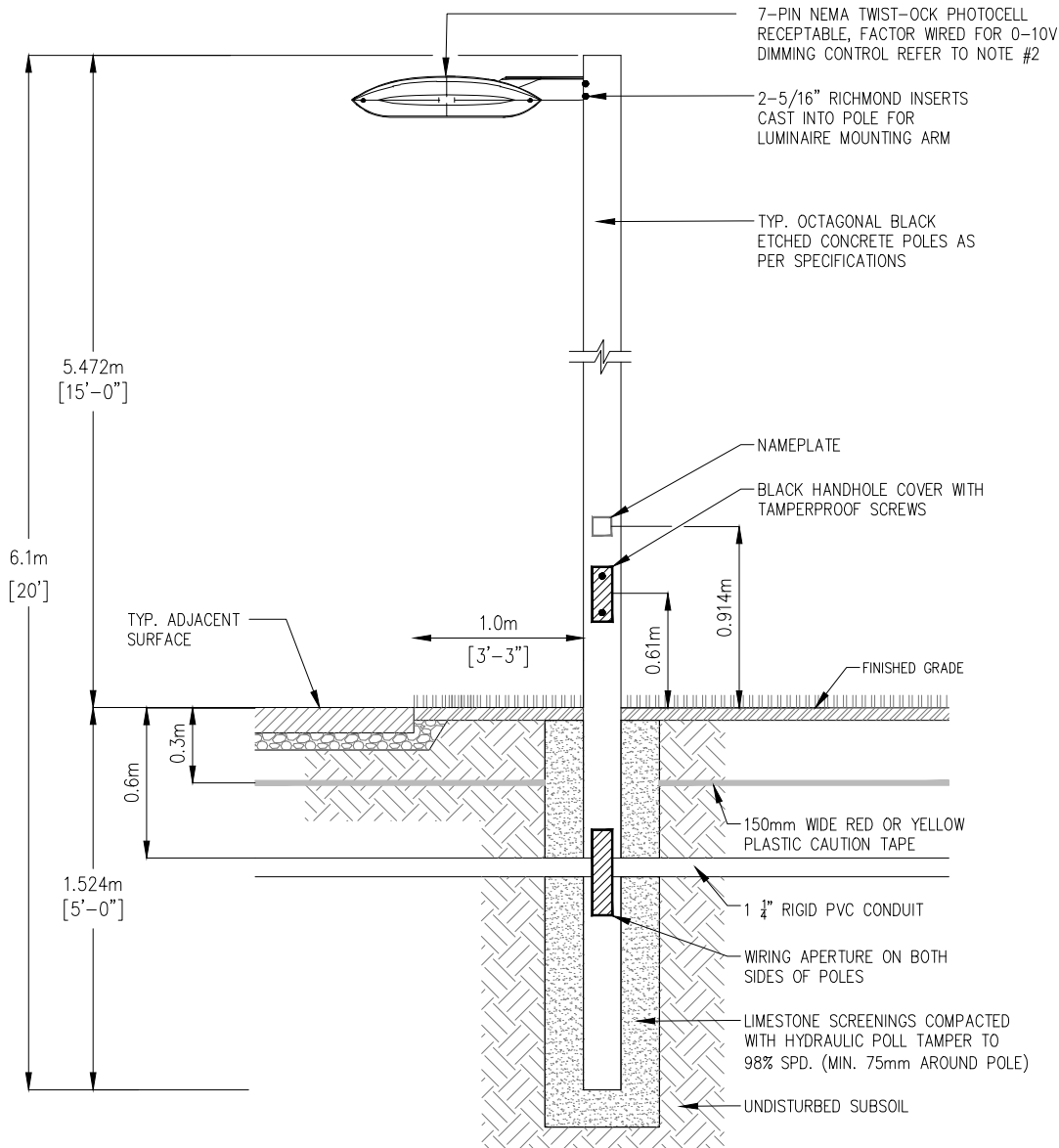

**NOTES:**

1. IN ACCORDANCE WITH E.S.A. STANDARDS AND SPECIFICATIONS, WARNING TAPE MUST BE PLACED 0.3m BELOW FINAL GRADE OVER ALL STREETLIGHT DUCTS INSTALLED IN AN OPEN TRENCH METHOD.
2. ALL FIXTURES MUST BE EQUIPPED WITH AN ANSI C136.41 COMPLIANT 7-PIN NEMA TWIST-LOCK PHOTOCELL RECEPTACLE, FACTORY WIRED FOR 0-10V DIMMING CONTROL.
3. CABLE RACEWAY IN POLE MUST BE OF SUFFICIENT DIAMETER TO ACCOMMODATE A DOUBLE RUN OF U/G CABLE UP TO THE HANDHOLE.
4. COPPER GROUND WIRE AT HANDHOLE IN ACCORDANCE WITH C.S.A. STANDARDS.
5. HANDHOLE AND NAMEPLATE TO BE ON HOUSE SIDE OF POLE.

4.		
3.		
2.		
1.		
REVISIONS		DATE
<b>CITY OF VAUGHAN ENGINEERING STANDARD</b>		
<b>6.1m (20') POLE ASSEMBLY WALKWAY / PATHWAY LIGHTING</b>		
NOT TO SCALE	DESIGNED: _____	STD. DWG.
REVISION: _____	DATE: _____ 2023	<b>SL-133</b>

FILE: C:\Infrastructure\Delivery\Infrastructure Programming\PMO\City Standards\Design Criteria\2020-21\City Standards\Update Folders\CityStandardsDrawings\_CAD\_2021\FRW-101 - Chain Link Security Fence.dwg

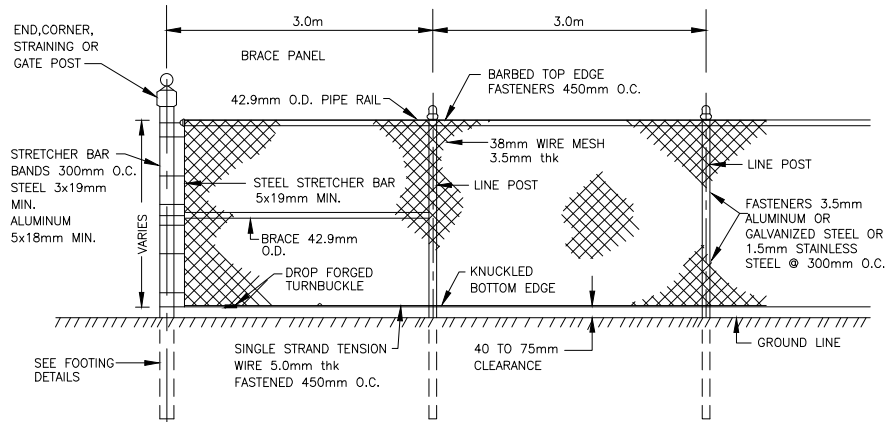

**FENCE DETAILS**

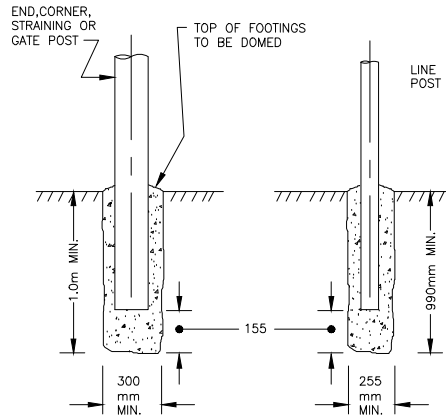

**FOOTING DETAILS**

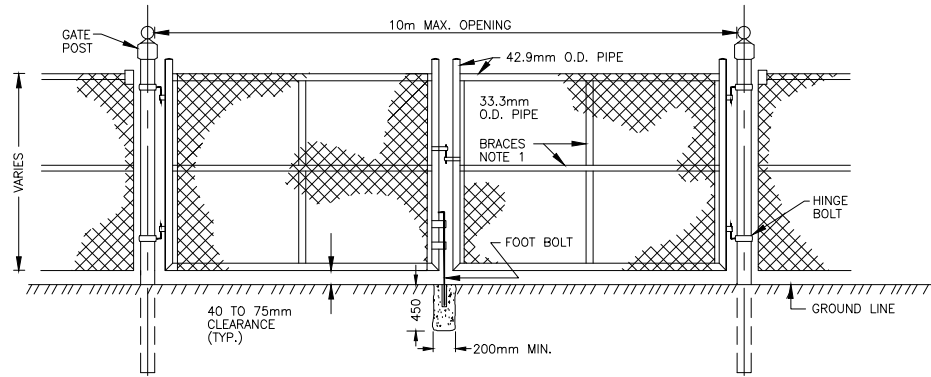

**DOUBLE GATE**

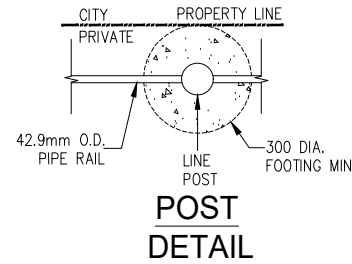

**POST DETAIL**

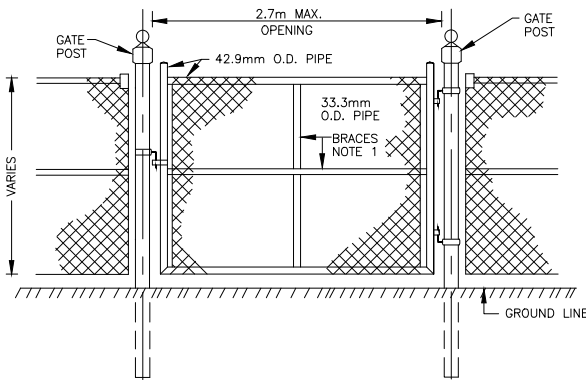

**SINGLE GATE**

DESCRIPTION	OD (mm)	LENGTH NOTE 2	
		STANDARD (m)	STANDARD WALLS(m)
LINE	60.3	2.7	2.0
END, CORNER, STRAINING AND GATE (5.5m MAX OPENING)	88.9	2.9	2.3
GATES (10m MAX OPENING)	114.3	2.9	-

**m** DIMENSIONS IN METRES EXCEPT AS NOTED

**NOTES**

- PIPE BRACES: GATE LEAVES UP TO 1.8m WIDE—REQUIRES HORIZONTAL BRACES ONLY.  
GATE LEAVES OVER 1.8m WIDE—REQUIRES BOTH HORIZONTAL AND VERTICAL BRACES
- POST LENGTH: FOR FABRIC WIDTHS GREATER THAN 1829mm THE POST SHALL BE INCREASED BY THE AMOUNT OF THE DIFFERENCE.
- ALL FENCE COMPONENTS TO BE BLACK COATED VINYL.
- BLACK FABRIC TO BE 3.5mm THICK WIRE WITH BLACK VINYL COATING.
- ALL PIPING SHALL BE STANDARD CONTINUOUS WELD, SCHEDULE 40 PIPE, GALVANIZED. NO TUBING, CONDUIT OR OPEN SEAM MATERIAL WILL BE PERMITTED.

4.		
3.		
2.		
1.		
REVISIONS		DATE



CITY OF VAUGHAN ENGINEERING STANDARD

**CHAIN LINK SECURITY FENCE**

NOT TO SCALE      DESIGNED: \_\_\_\_\_  
REVISION: \_\_\_\_\_      DATE: DEC. 2020

STD. DWG.  
**FRW - 101**

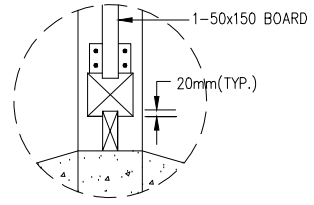
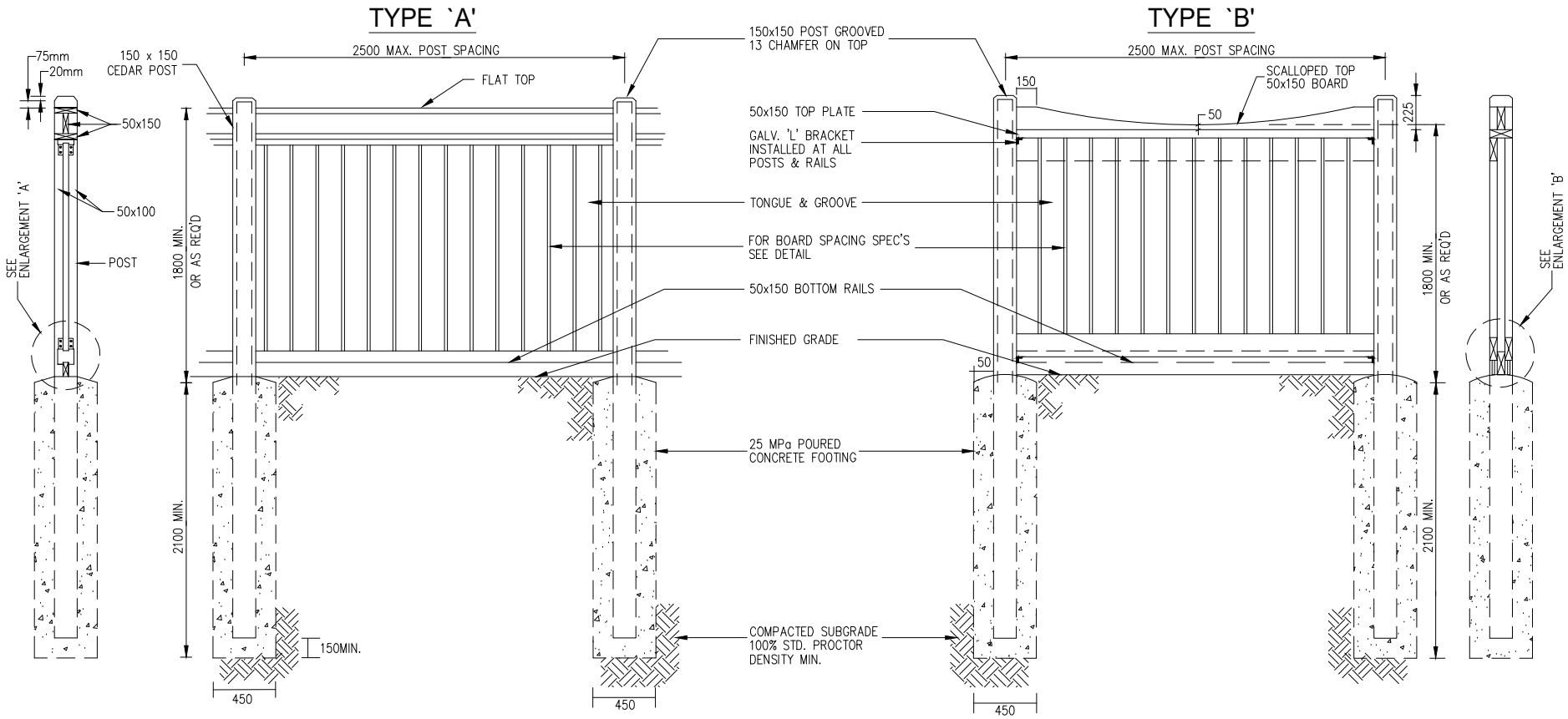

**ENLARGEMENT 'A'**

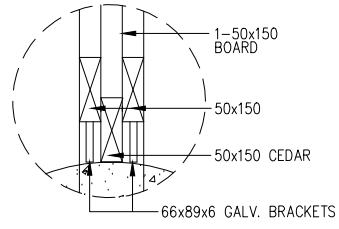

**ENLARGEMENT 'B'**

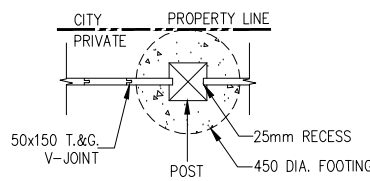

**TONGUE & GROOVE  
DETAIL**

**mm** DIMENSIONS IN MILLIMETRES  
EXCEPT AS NOTED

4.		
3.		
2.		
1.		
REVISIONS		DATE



CITY OF VAUGHAN ENGINEERING STANDARD

**ACOUSTIC WOOD FENCE**

- NOTE**
1. REFER TO STD. DWG. FRW-104 FOR SPECIFICATIONS.
  2. FENCE HEIGHT HIGHER THAN 1.8m IS SUBJECT TO THE APPROVAL OF THE CITY.
  3. FENCE POSTS TO BE INSTALLED AT ALL LOT CORNERS WHERE IT ABUTS ANOTHER PRIVATE PROPERTY

NOT TO SCALE      DESIGNED: \_\_\_\_\_      STD. DWG.  
 REVISION: \_\_\_\_\_      DATE: \_\_\_\_\_ DEC. 2020      **FRW - 102**

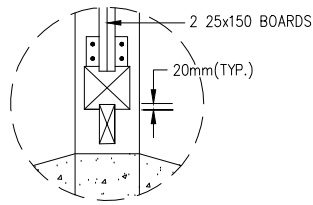
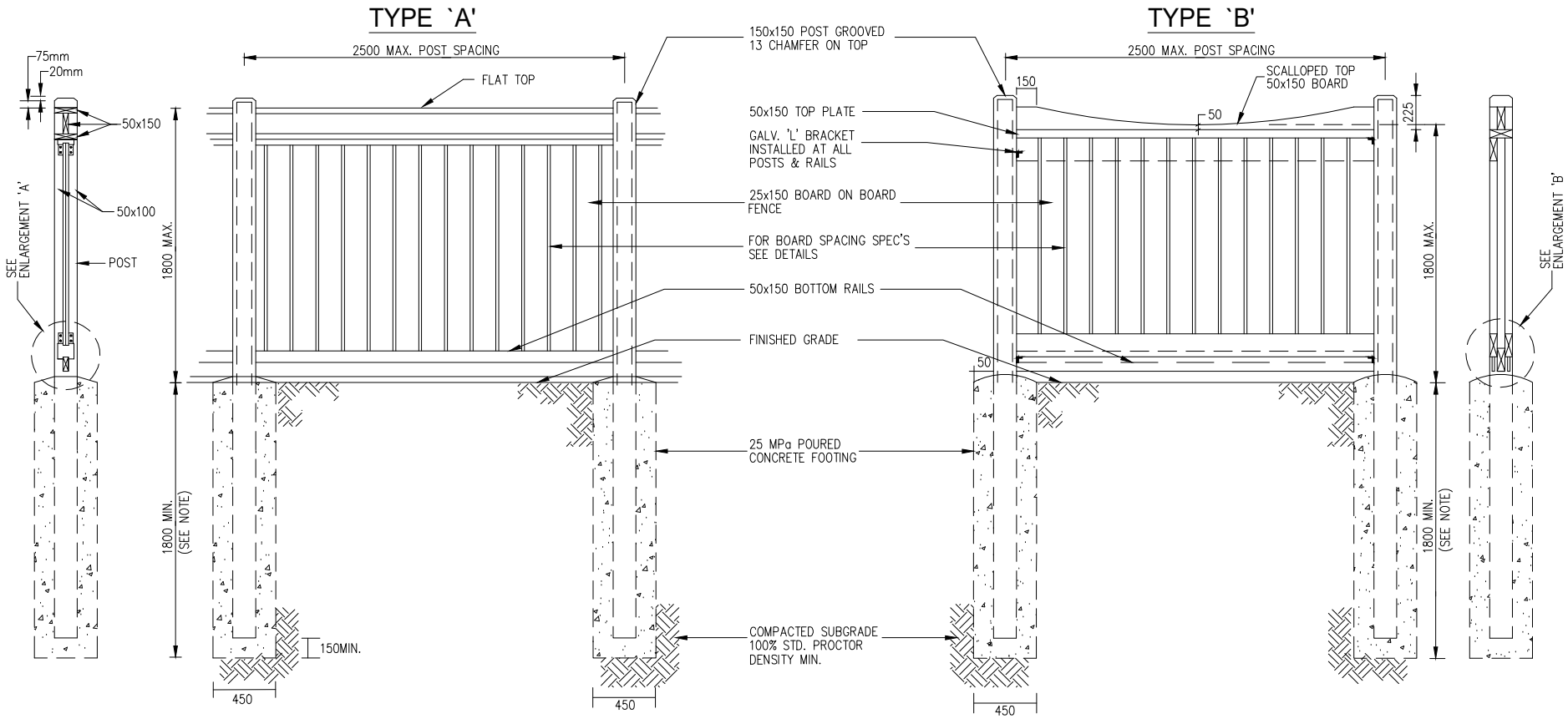

**ENLARGEMENT 'A'**

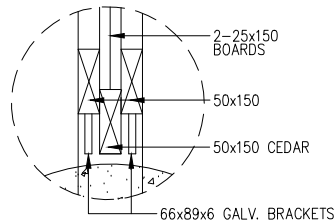

**ENLARGEMENT 'B'**

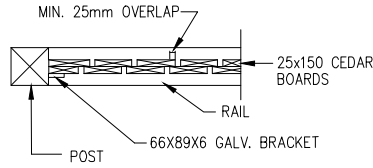

**BOARD ON BOARD  
DETAIL**

**mm** DIMENSIONS IN MILLIMETRES  
EXCEPT AS NOTED

4.		
3.		
2.		
1.		
REVISIONS		DATE



CITY OF VAUGHAN ENGINEERING STANDARD

**PRIVACY WOOD FENCE**

NOT TO SCALE      DESIGNED: \_\_\_\_\_  
 REVISION: \_\_\_\_\_      DATE: DEC. 2020

STD. DWG.  
**FRW - 103**

**NOTE**  
 THE DEPTH IS TO BE 1800mm MINIMUM ON NATIVE SOIL.  
 FOR NON-NATIVE SOIL, OR FENCE HEIGHT GREATER THAN 1800mm,  
 THE DEPTH IS TO BE RECOMMENDED BY A PROFESSIONAL SOIL  
 ENGINEER.  
 REFER TO STD. DWG. FRW-105 FOR SPECIFICATIONS.

FILE: C:\Infrastructure\Delivery\Infrastructure Programming\PMO\City Standards\Design Criteria\2020-21\City Standards Update\Folders\CoStandardDrawings\_CAD\_2021\FRW-104 - Acoustic-Privacy Fence Notes.dwg

NOTES

1. ALL WOOD SHALL BE WESTERN RED CEDAR, SELECTED MAINLY FOR GOOD APPEARANCE AND FREE OF WANE AND BARK POCKETS. ALL TORN GRAIN SHALL BE FREE, ELIMINATED BY SANDING AND PLANING. MEMBERS EXHIBITING MODERATE TO HEAVY KNOTS SHALL BE WELL DISTRIBUTED THROUGHOUT THE INSTALLATION. POST SHALL BE SELECT KNOTTY (NLGA131A) RETENTION OF 20KG/SQ M SURFACE DENSITY.
2. ALL WOOD SHALL BE DRESSED FOUR SIDES.
3. ALL TIMBER CUTS SHALL BE STRAIGHT AND PLUMB.
4. MOISTURE CONTENT OF WOOD SHALL NOT EXCEED 14% AT THE TIME OF CONSTRUCTION.
5. ALL WOOD TO BEAR GRADING STAMP OF C.I.S. CERTIFIED AGENCY.
6. TREAT BOTTOM SKIRT BOARD WITH C.C.A. PRESERVATIVE TO A RETENTION OF 4.0KG/M<sup>2</sup>.
7. ALL FENCES SHALL BE INSTALLED WITHIN 30 DAYS OF INSTALLATION, WEATHER PERMITTING.
8. STAIN FOR WOOD FENCE- STAIN SHALL CONSIST OF 2 COATS OF:
  - A BASE OF BLENDED RESINS AND OILS IN A WATER SUSPENSION.
  - SUSPENDED SOLIDS WHICH ARE NOT LESS THAN 21% AND NOT GREATER THAN 31% BY VOLUME.
  - V.O.C.'S (VOLATILE ORGANIC COMPOUNDS) WHICH ARE NOT IN EXCESS OF 350G/L IN ACCORDANCE WITH A.S.T.M. D-2369.
  - LEVELS OF LIQUID MICROBICIDES AND ANY OTHER POTENTIAL TOXIC SUBSTANCES WHICH ARE ENVIRONMENTALLY SAFE (NOT REQUIRING PROVINCIAL OR FEDERAL REGISTRATION).
  - NONE OF THE FOLLOWING HAZARDOUS SUBSTANCES:
    - \* FOLPET [N-(TRICHLOROMETHYLTHIO) PHTHALIMIDE]
    - \* BIS (TRIBUTYL TIN) OXIDE
    - \* COPPER NAPHTHENATE
    - \* COPPER 8 QUINOLINOLATE
    - \* ZINC NAPHTHENATE
  - SUFFICIENT OXIDE PIGMENTS TO OBTAIN DESIRED COLOUR TONE AND LEVEL OF OPACITY (COLOUR TO BE APPROVED BY LANDSCAPE ARCHITECT).
9. SECTION OF POST IMBEDDED IN CONCRETE FOOTING TO BE DIPPED IN CREOSOTE.
10. LAG SCREWS AND BOLTS SHALL BE GALVANIZED AND CONFORM TO ASTM A307.
11. ALL GALVANIZING TO BE HOT DIPPED IN CONFORMANCE TO CSA STANDARD 6164.
12. THE ACOUSTIC FENCE SHALL HAVE A MINIMUM FACE DENSITY OF 20 kg/m<sup>2</sup>.
13. ALL NAILS GALVANIZED ARDOX, CONFORMING TO CSA STANDARD, AND 75MM UNLESS NOTED OTHERWISE. ALL NAILS TO BE EVENLY SPACED AND SET NOT LESS THAN 25MM FROM EDGE OF ANY MEMBER.

RAILS - 3 NAILS TO POST AT EACH END, 3 NAILS THRU BOTTOM FRONT RAIL TO VERTICAL MEMBERS AND 3 NAILS TO SKIRT BOARD IN STAGGERED PATTERN. CONTINUE ->

SKIRT RAIL - 2 NAILS TO POST AT EACH END.

FACIA BOARD - 2 NAILS (50MM) EACH END TO VERTICAL MEMBERS AND 5 NAILS IN STAGGERED PATTERN ALONG BOARD.

VERTICAL MEMBERS - 2 NAILS (88MM) TOP AND BOTTOM TO RAILS.

COPING - 2 NAILS THRU EDGES TO POST AT EACH END AND 6 NAILS THRU TOP TO VERTICAL MEMBERS.

14. COUNTER-SINK ALL LAG SCREWS AND BOLTS AND DRIVE ALL NAIL HEADS BELOW SURFACE OF WOOD.
15. FOUNDATION DESIGN IS BASED ON AN ALLOWABLE SOIL PRESSURE OF 95KN/M<sup>2</sup>. OBTAIN PROFESSIONAL SOIL ENGINEER'S APPROVAL BEFORE CASTING CONCRETE FOR FOUNDATION.
16. DESIGN WIND SPEED 80KM/HR, GUST TO 100KM/HR.
17. CONCRETE FOR FOOTINGS SHALL HAVE A MINIMUM COMPRESSIVE STRENGTH OF 25 MPA IN 28 DAYS.
18. FOR ACOUSTIC FENCE, BOTTOM RAIL SHALL BE SET ON GRADE. WHERE DRAINAGE IS TO BE CONVEYED THROUGH THE BARRIER, THEN THE DESIGN SHALL COMPLY WITH STANDARD DESIGN CRITERIA FIG. I-6
19. FIRE HOSE ACCESS TO BE DESIGNED IN ACCORDANCE WITH O.P.S.D. 998.101 & 998.131.
20. FENCES CONSTRUCTED ON BERMS:
  - A) EXTEND FOOTINGS 300MM INTO UNDISTURBED SUB-GRADE.
  - B) COMPACT BERMS TO A MINIMUM OF 100% STANDARD PROCTOR DENSITY.
  - C) CONSTRUCT BERMS WITH A 1000MM FLAT TOP AND SIDE SLOPES NO STEEPER THAN 3:1.

4.		
3.		
2.		
1.		
REVISIONS		DATE



CITY OF VAUGHAN ENGINEERING STANDARD

**ACOUSTIC / PRIVACY FENCE  
NOTES**

NOT TO SCALE

DESIGNED: \_\_\_\_\_

STD. DWG.

REVISION: \_\_\_\_\_

DATE: DEC. 2020

**FRW - 104**

FILE: G:\Infrastructure Delivery\Infrastructure Programming\PMO\City Standards\Design Criteria\2020-21\City Standards Update\Folders\Co\StandardDrawings\_CAD\_2021\FRW-105 - Pedestrian+Bicycle Hand Rail.dwg

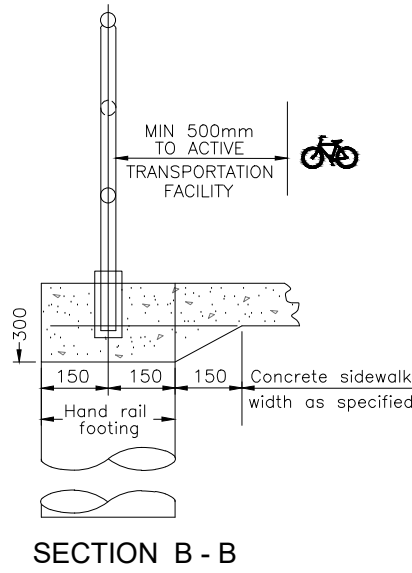
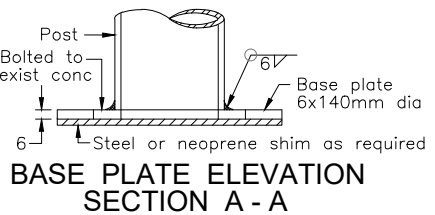
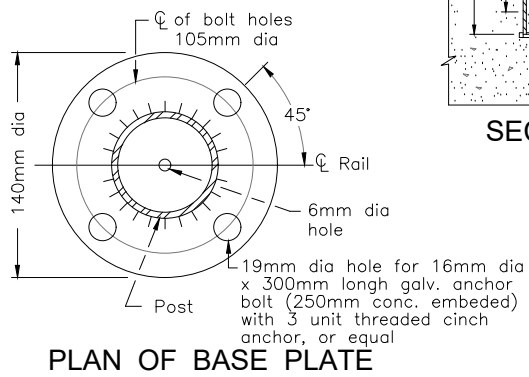
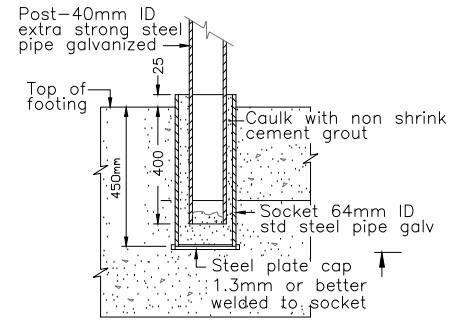
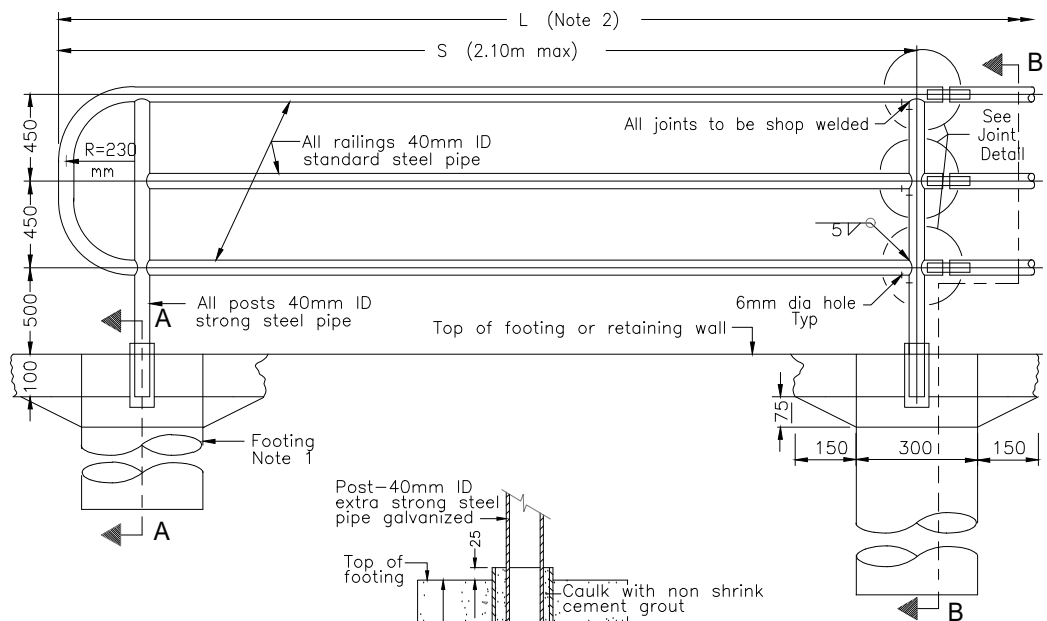

**NOTES:**

- 1 Anchor leveling (base) plates for hand rail posts to be set in centre of 300mm dia.x1200mm deep conc. footings.
- 2 Number of panels=  $\frac{\text{Total length(L)}-600\text{mm}}{\text{Length of panels(S)}}$
- 3 6mm dia holes are to permit gases to escape during galvanizing.
- A Class of concrete – 32MPa min after 28 days.
- B Hand rail to be hot dip – galvanized after fabrication in conformance with CSA G-164.
- C Posts shall be vertical. All exposed corners to be ground smooth.
- D Welding shall conform to the latest issue of CSA specification W59.
- E Pipe shall be supplied accordance with ASTM Designation A120.

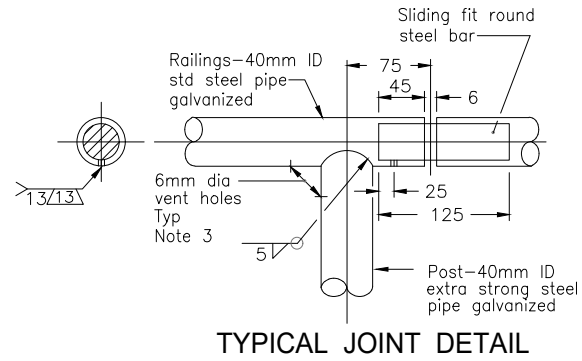

4.		
3.		
2.		
1.		
REVISIONS		DATE



CITY OF VAUGHAN ENGINEERING STANDARD

**PEDESTRIAN / BICYCLE HAND RAIL**

NOT TO SCALE      DESIGNED: \_\_\_\_\_      STD. DWG.  
 REVISION: \_\_\_\_\_      DATE: DEC. 2020      **FRW - 105**

**mm** DIMENSIONS IN MILLIMETRES EXCEPT AS NOTED

**NOTE:**  
 THIS STANDARD TO BE USED IN PLACE OF OPSD 980.101 WHERE ADDITIONAL RAIL HEIGHT IS REQUIRED (SUCH AS BICYCLE TRAIL).

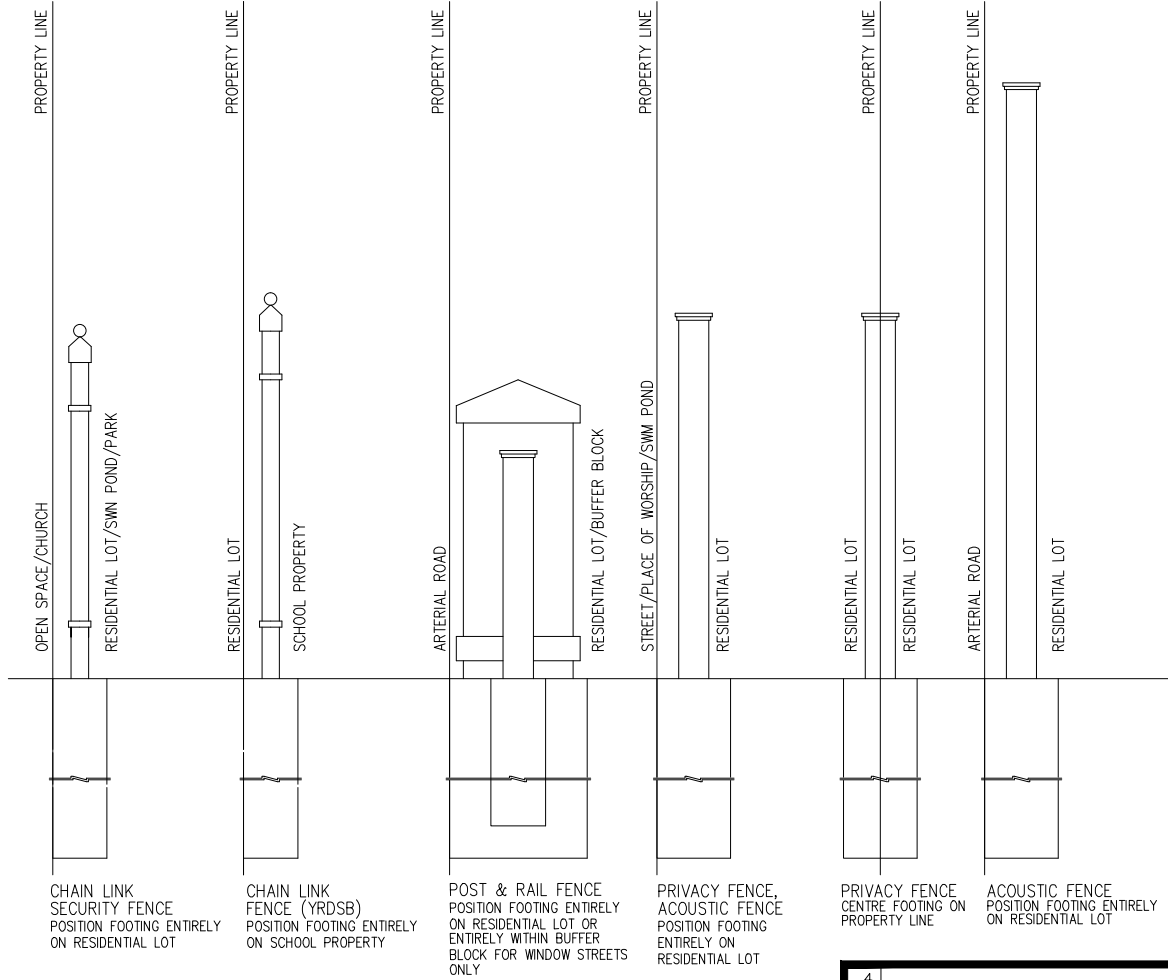

CHAIN LINK SECURITY FENCE (YRDSB) POSITION FOOTING ENTIRELY ON RESIDENTIAL LOT

CHAIN LINK FENCE (YRDSB) POSITION FOOTING ENTIRELY ON SCHOOL PROPERTY

POST & RAIL FENCE POSITION FOOTING ENTIRELY ON RESIDENTIAL LOT OR ENTIRELY WITHIN BUFFER BLOCK FOR WINDOW STREETS ONLY

PRIVACY FENCE, ACOUSTIC FENCE POSITION FOOTING ENTIRELY ON RESIDENTIAL LOT

PRIVACY FENCE CENTRE FOOTING ON PROPERTY LINE

ACOUSTIC FENCE POSITION FOOTING ENTIRELY ON RESIDENTIAL LOT

**NOTES:**

1. ALL FENCE, INCLUDING THEIR FOOTINGS/FOUNDATIONS, MUST BE LOCATED ENTIRELY OUTSIDE OF ANY 0.3m RESERVES.

4.		
3.		
2.		
1.		
REVISIONS		DATE



CITY OF VAUGHAN ENGINEERING STANDARD

**FENCE TYPES & PLACEMENT**

**mm** DIMENSIONS IN MILLIMETRES EXCEPT AS NOTED

NOT TO SCALE      DESIGNED: \_\_\_\_\_  
 REVISION: \_\_\_\_\_      DATE: DEC. 2020

STD. DWG.  
**FRW - 106**